

FLEXSTEEL®

W1064-02

Lamp Table

IMPORTANT NOTE

Carefully remove all the parts from the carton and put them individually on a soft cloth to prevent damage to the parts.

We have taken great care in the design of this product and request that you carefully and strictly follow our assembly instructions to ensure a completed product as it was designed.

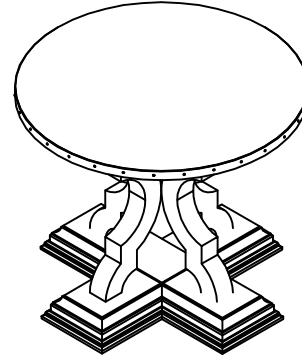

Parts List

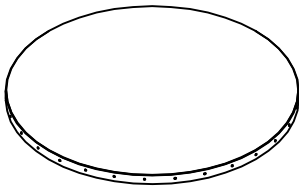

A. Table Top
1 piece

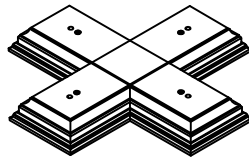

B. Base
1 piece



C. Side Section
4 pieces

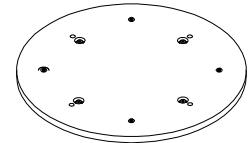

D. Assembly Panel
1 piece

Hardware List



Bolt
12 pieces (+ 1 extra)



Flat Washer
12 pieces (+ 1 extra)



Spring Washer
12 pieces (+ 1 extra)



Hex Key
1 piece

Tool (s) Recommended for assembly : Level

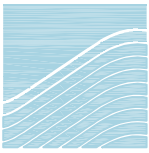

IMPORTANT

- Do not tighten up all the screws until each part is properly assembled.
- You should keep Hex Key in a safe place as you may need to tighten up the bolts in the future.
- Use a soft cloth between these parts and the floor.

STEP 1

Attach all the Side Sections (C) to the Assembly Panel (D) with the Bolt, Spring Washer and Flat Washer, tighten with the Hex Key. (See Figure 1)

Note: Do not fully tighten the bolts at this stage

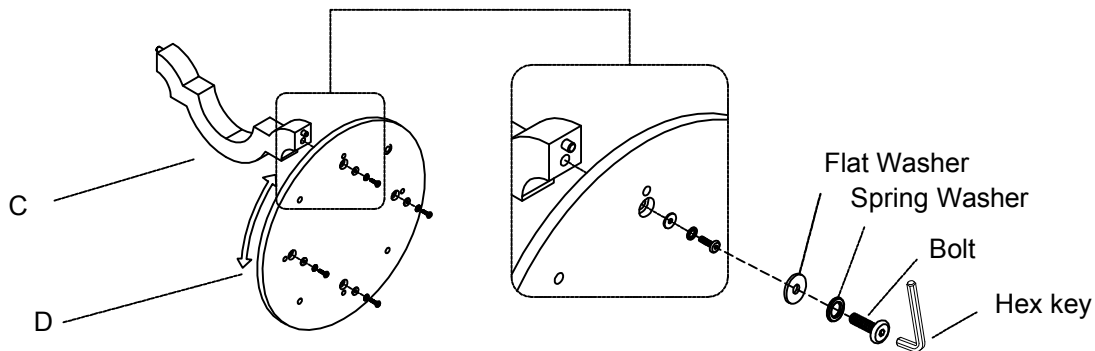

Figure 1

STEP 2

Attach the assembled base to the Base (B) with the Bolt, Spring Washer, Flat Washer, tighten with the Hex Key. (See Figure 2)

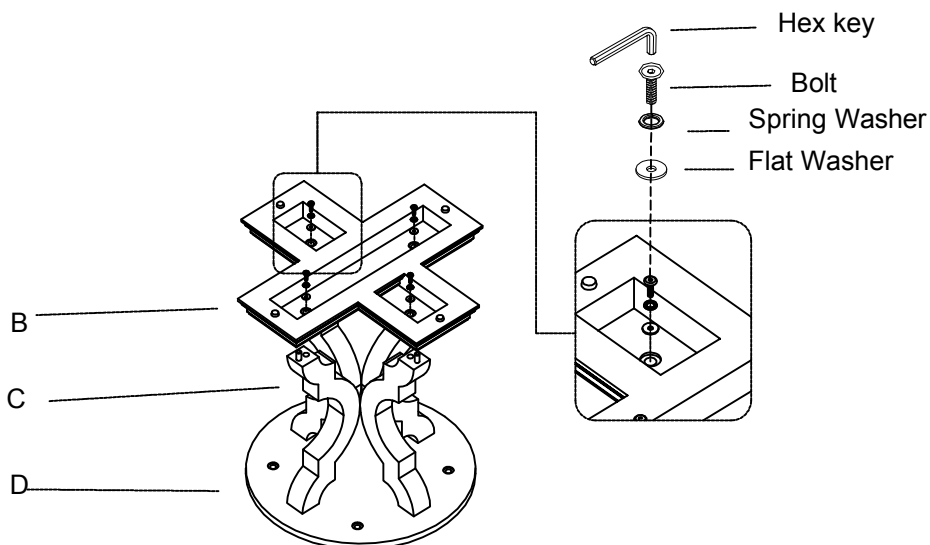
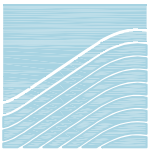
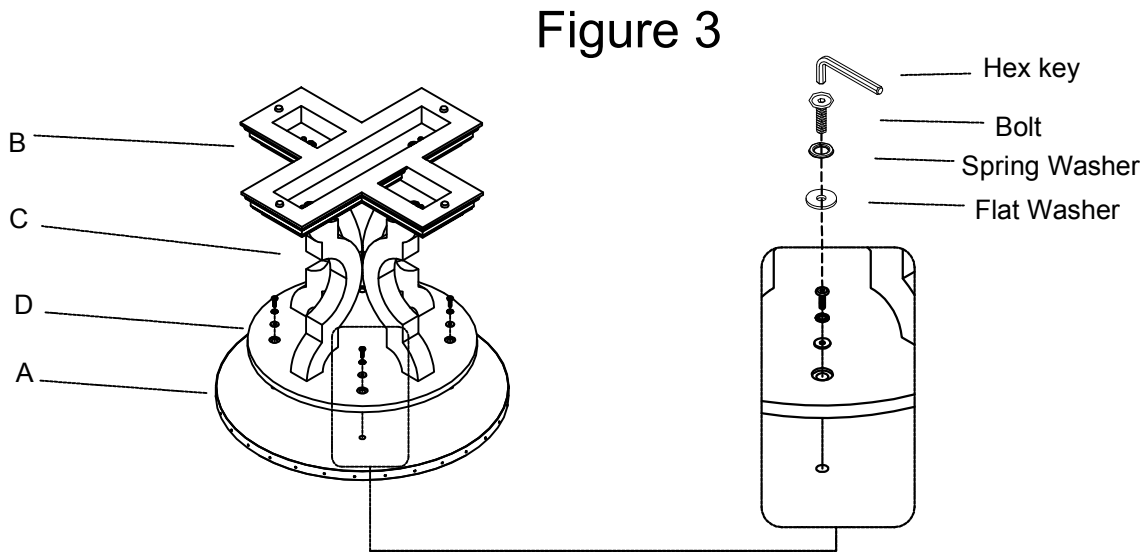

Figure 2



STEP 3

Carefully place the Table Top (A) upside down on a soft surface. Attach the assembled base to the Table Top (A) with the Bolt, Spring Washer, Flat Washer and fully tighten all with the Hex Key. (See Figure 3)



STEP 4

Adjust the levelers on the base of the table until the furniture is level. (See Figure 4)

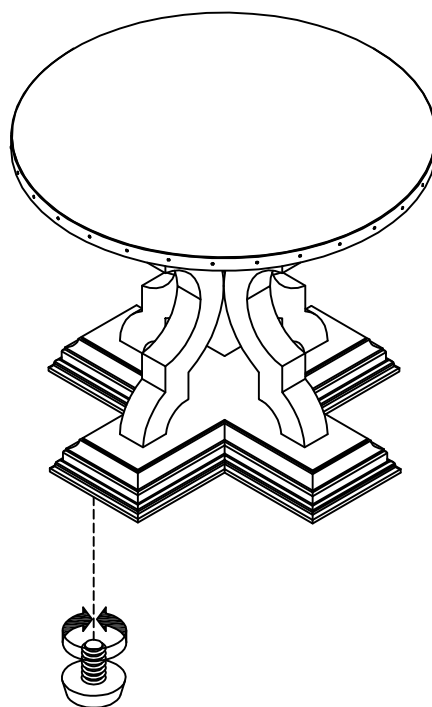

Figure 4