

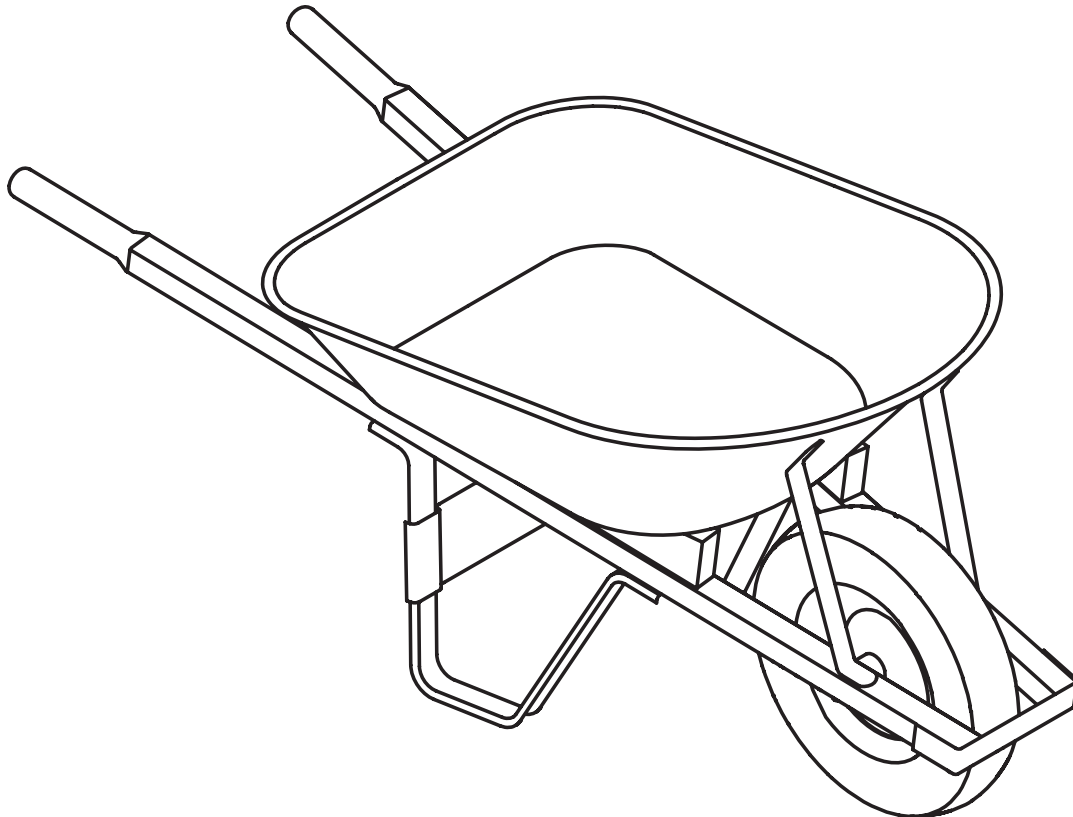

# USE AND CARE GUIDE

## 6.0 CUBIC FOOT WHEELBARROW



Questions, problems, missing parts?  
Before returning to the store, call Corona Customer Service  
Mon - Fri, 7:30 AM - 4:30 PM PST

**(800) 847-7863**

**[WWW.CORONATOOLSUSA.COM](http://WWW.CORONATOOLSUSA.COM)**

Retain this manual for future use.

# Safety Information



**DANGER:** Changing tires can be dangerous and should be done by trained personnel only.



**IMPORTANT:** Please read and understand this entire manual before beginning assembly or use of this product.

## Pre-Installation

### PLANNING INSTALLATION

Make sure all parts are present and correct.

### TOOLS REQUIRED



Large slotted  
screwdriver



1/2 in. wrench  
and/or ratchet  
and deep socket

### HARDWARE INCLUDED



**NOTE:** Hardware not shown to actual size.

Part	Description	Quantity
AA	130 mm long M8 Bolts, Washers, and Nuts	2
BB	80 mm long M8 Bolts, Washers, and Nuts	2
CC	60 mm long M8 Bolts, Washers, and Nuts	4
DD	50 mm long M8 Bolts, Washers, and Nuts	2
EE	20 mm long M8 Bolts, Washers, and Nuts	6

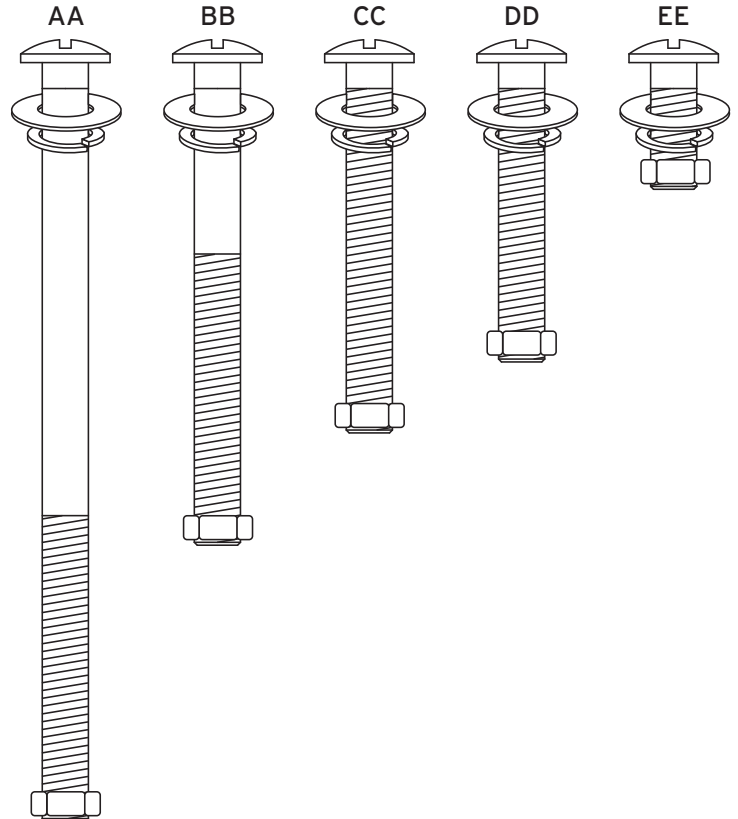

# Pre-Installation (continued)

## PACKAGE CONTENTS

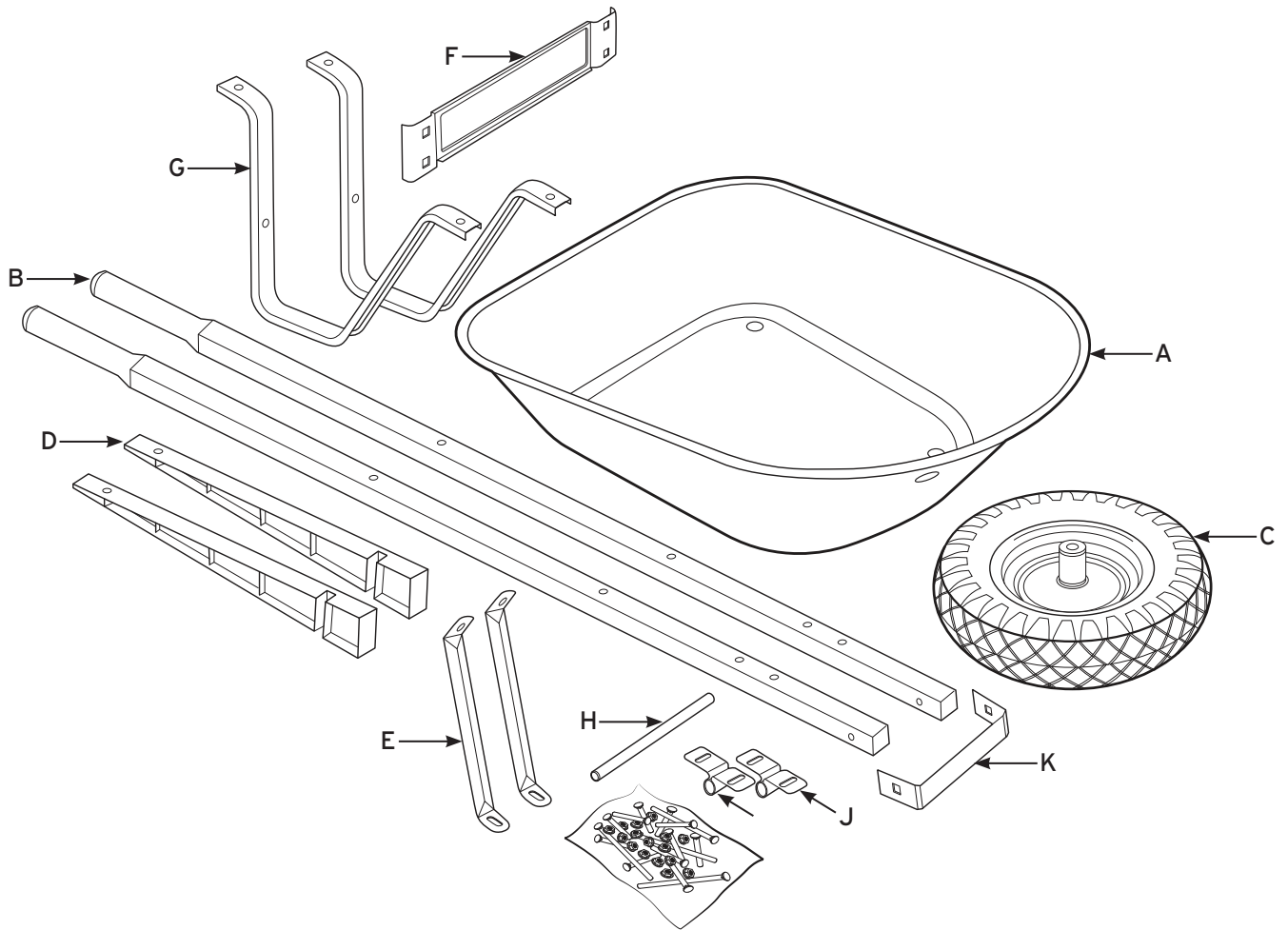

Part	Description	Quantity
A	Tray	1
B	Handles	2
C	Wheel	1
D	Risers / Wedges	2
E	Tray Braces	2
F	Leg Brace	1
G	Legs	2
H	Axle	1
I	Right Axle Bracket	1
J	Left Axle Bracket	1
K	Front Wheel Guard	1

# Assembly

## 1 Building Handles



**NOTE:** The open side of the “C” cutout in the top and bottom surfaces of the wedge should face each other when assembled.

- Orient the handles (B) level as shown.
- The holes in the handle (B) nearest the rounded gripping end should align with the narrow end of the riser/wedge (D).
- The next/second set of holes in the handle (B) should align with the taller end of the riser/wedge (D).

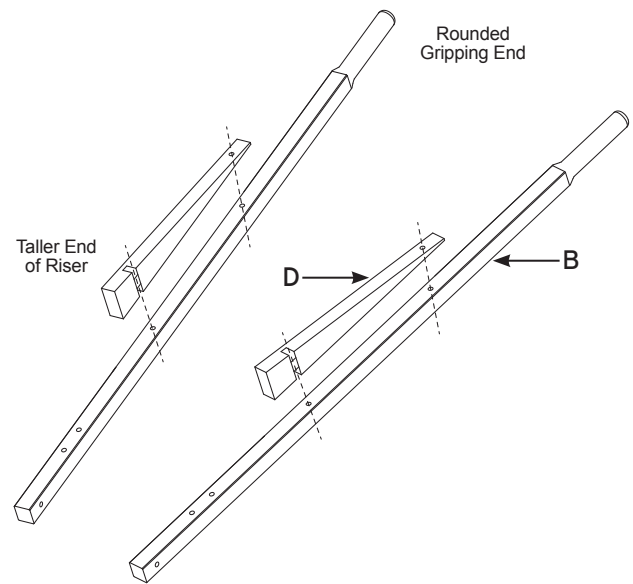

## 2 Attaching Tray to Handles



**NOTE:** The dome heads on the bolts should be flush with the inside of the tray. Do not install nuts or washers yet.

- Place the tray (A) on top of the risers (D) and handles (B), ensuring the holes through all 3 components align.
- Drop two 130 mm bolts (AA) down through the deeper portion of the tray (A), the thicker portion of the wedge/riser (D), and the corresponding holes in the handles (B).
- Drop two 80 mm bolts (BB) down through the shallower portion of the tray (A), the thinner portion of the wedge/riser (D) and the holes nearest the rounded gripping end of the handles (B).

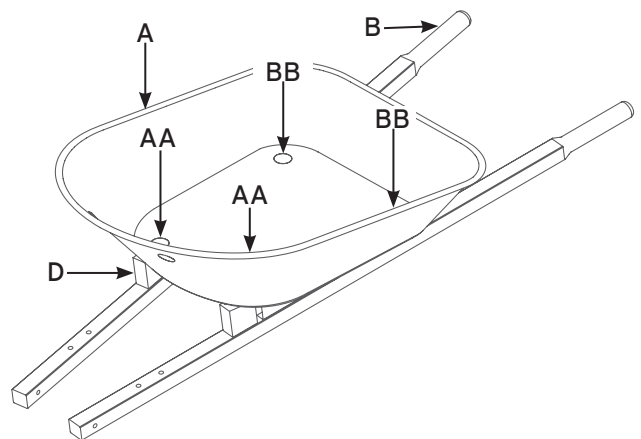

## Assembly (continued)

### 3 Assembling the Leg Brace



**NOTE:** Bolt heads go on one side. Washers, lock washers, and nuts go on the other - in that order.



**RECOMMENDED:** All hardware be installed only finger tight until wheelbarrow is completely assembled.

- Loosely assemble the legs (G) and leg brace (F) together as shown using four 20 mm bolts, washers, lock washers, and nuts (EE).

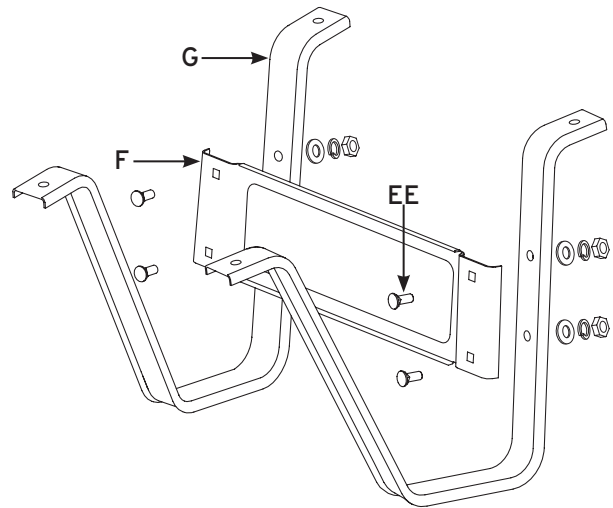

### 4 Attaching the Leg Brace

- Orient the leg (G) and leg brace (F) assembly, with the handles (B), riser/wedges (D) and tray (A) facing the rounded gripping end of the handles (B).
- Use the 130 mm bolts (AA) and 80 mm bolts (BB) inserted in step 2 to pass through the holes on the legs (G). Secure the bolts (AA, BB) with flat washers, lock washers and nuts on the bottom side of the legs (G).

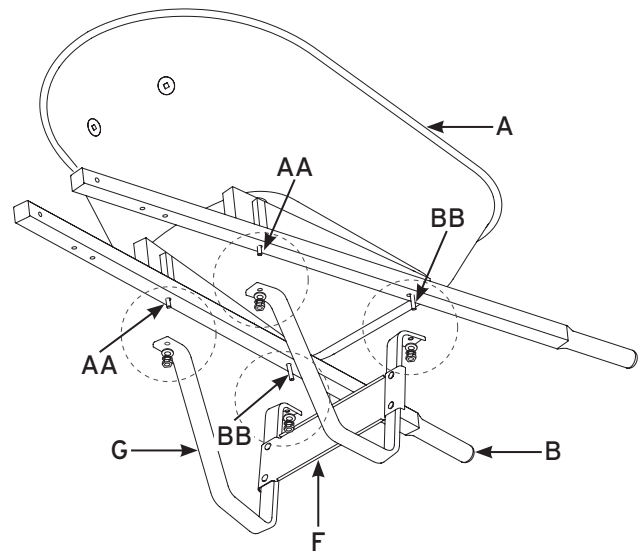

## Assembly (continued)

### 5 Attaching the Front Wheel Guard

- Attach front wheel guard (K) to the wheel end of the handles (B) using the two 50 mm bolts, washers, lock washers, and nuts (DD).

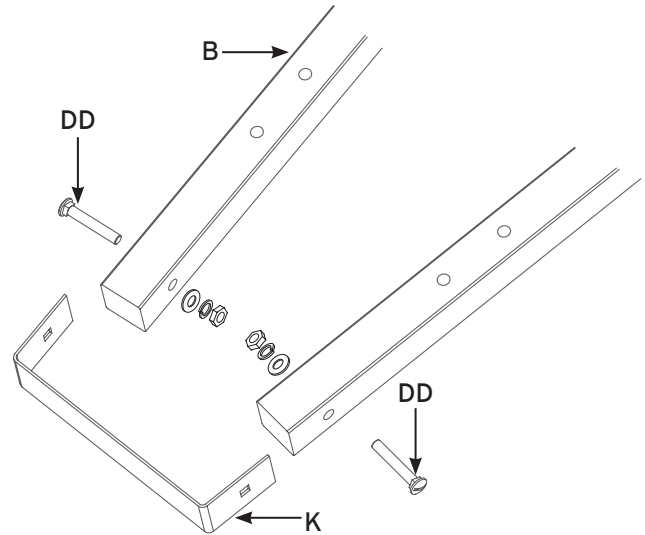

### 6 Securing the Tray Braces



**NOTE:** These brackets are directional. Orient them so that the longer ends face the tray and the shorter ends face the wooden handles.

- Attach and secure the tray braces (E) to the tray (A) using two 20 mm bolts, washers, lock washers, and nuts (EE).

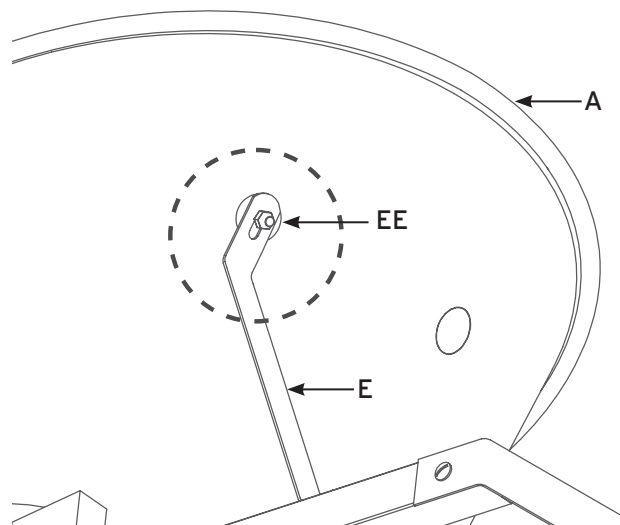

## Assembly (continued)

### 7 Attaching the Right Axle Bracket



**NOTE:** Do Not Tighten Yet.

- Loosely attach and secure the right axle bracket (I) to the handle (B) and tray stabilizer (E) using attach using two 60 mm bolts, washers, lock washers, and nuts (CC). The tray stabilizer (E) attaches to the front bolt hole on top of the handle (B). Bolts go in from the top and are secured below the bracket (I) with flat washers, lock washers and nuts.

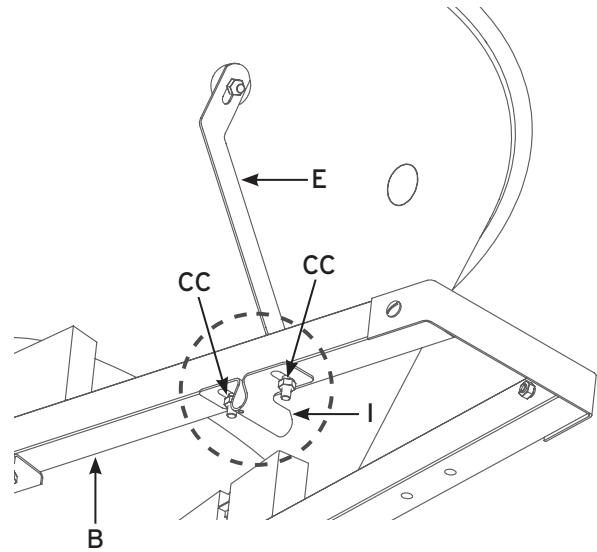

### 8 Attaching the Wheel Assembly

- With the wheelbarrow upside down (resting on its tray (A)), hold the wheel (C) in place and slide the axle (H) through the wheel (C) and into the right axle bracket (I).

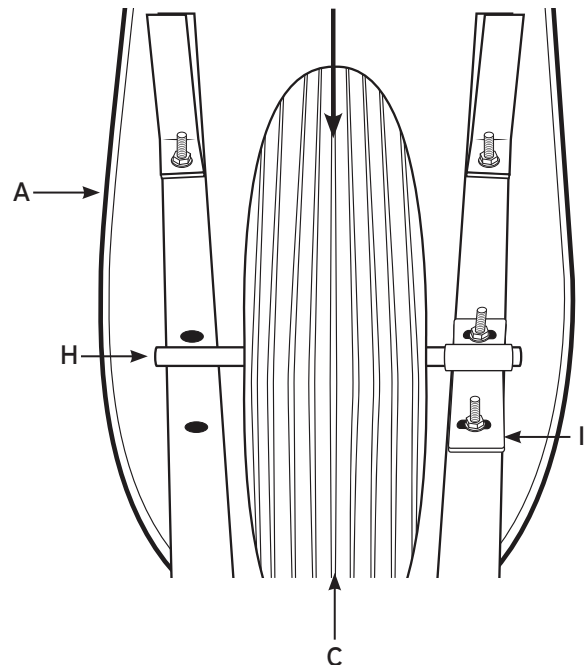

## Assembly (continued)

### 9 Attaching the Left Axle Bracket

- Slide the left axle bracket (J) onto the axle (H), and attach using two 60 mm bolts, washers, lock washers, and nuts (CC).

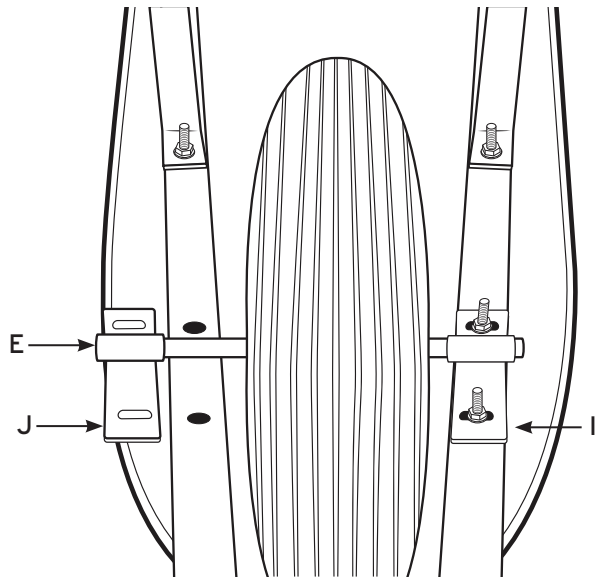

### 10 Tightening the Hardware

- Fully tighten all hardware prior to use.

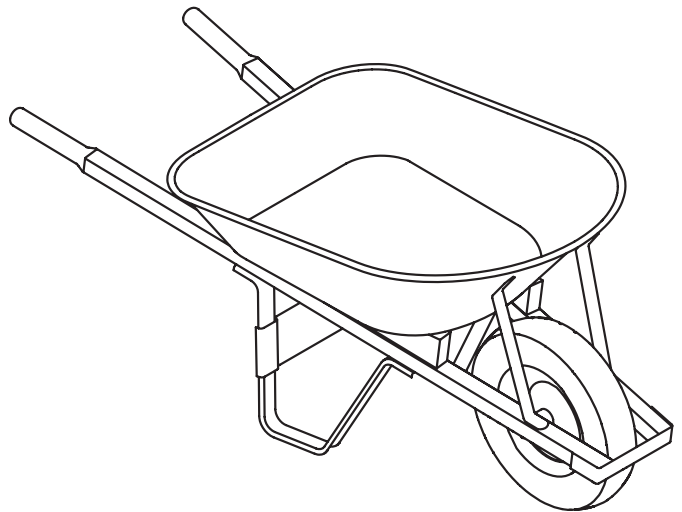

## Warranty

### LIMITED WARRANTY

#### WHAT IS COVERED

This product is guaranteed to be free of defects in materials and workmanship for 10 years from the date of purchase. If your tool is found to be defective within that period, Corona® will replace it free of charge or provide you with next steps to get it replaced.

[www.coronatoolsusa.com/corona-cs-warranty](http://www.coronatoolsusa.com/corona-cs-warranty)

LEARN MORE

