

SIMPLIHOME®

Sawhorse / Hawkins / Spokane

Metal / Wood Ladder Shelf with Storage

MODEL # AXCSAWM06-WAL

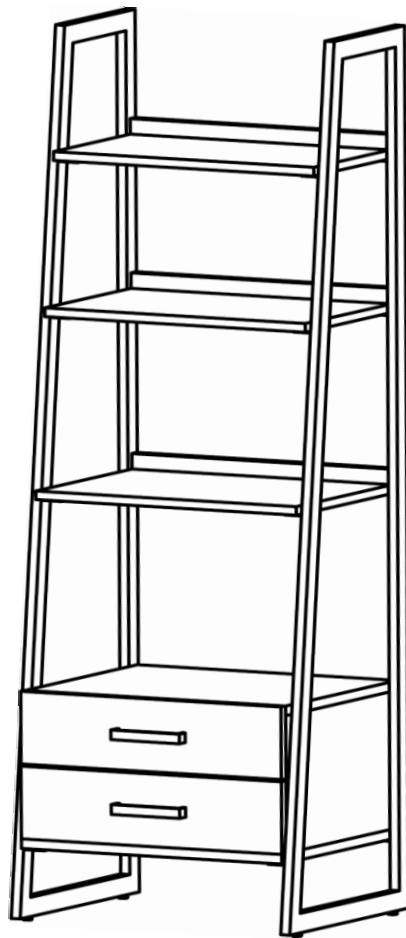

SIMPLIHOME®

Great quality is a right.

Thank you for shopping with Simpli Home,
America's top brand for high-value furniture.



It's time to register your product warranty.

It's quick and easy. And you'll be happy you did.



- ✓ Activate your **1-year** warranty
- ✓ Automatic entry to win a **\$500** gift certificate
- ✓ Earn instant rewards and **save**

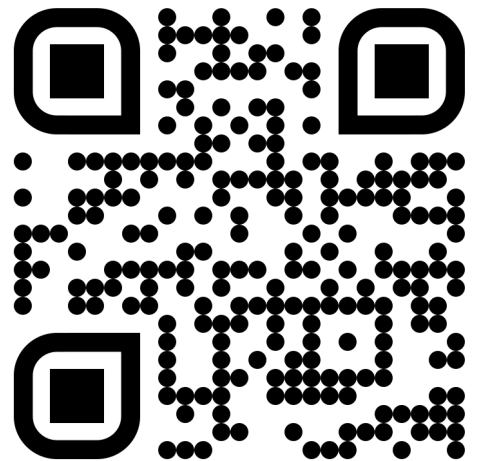

simpli-home.com/product-registration

SIMPLIHOME®

Review your product and collect rewards!

Thank you for your purchase! We hope you enjoy it. We'd love your feedback. Please share a review and get instant rewards!

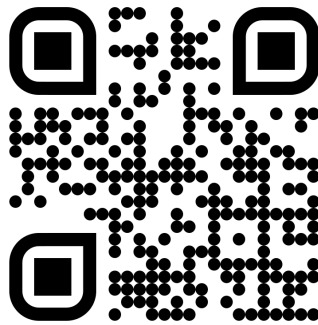

simpli-home.com/product-review



Share photos and get your cash back!



Send us images or share them on social and qualify for instant rewards. You may even receive store credit on your entire purchase!

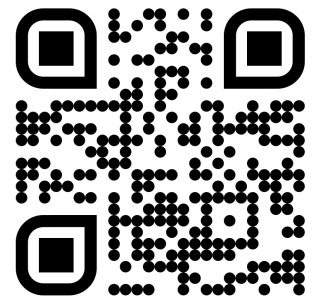
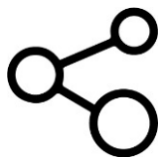

simpli-home.com/share-images

SIMPLIHOME®

For fastest customer service

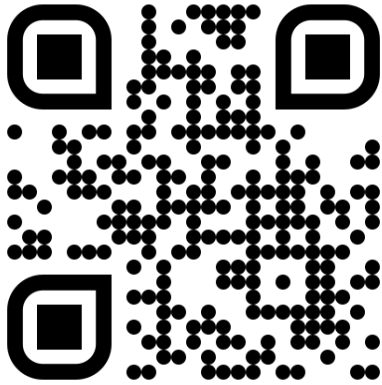

1. Open your phone's camera.
2. Point your phone's camera at the QR code to scan.
3. Click on the pop up.
4. You'll be taken to our customer service page.
5. Fill the form with your order information and issue.
6. Submit form.
7. A customer service associate will contact you.

Other ways to contact us...



Email Us

customerservice@simpli-home.com



Visit Us

Visit our site directly at
www.simpli-home.com



Call Us

1-866-518-0120
Monday to Friday
9am to 5pm EST

***If you've purchased from a retailer and you wish to return the product, please contact the retailer directly.**

IMPORTANT: Please read this manual carefully before beginning assembly of this product. Keep this manual for future reference.

Safety Information

Identify all the parts and hardware. Do not discard of the packaging until you have checked that you have all the parts and hardware required. Hardware package may have spare parts.

WARNING: This item contains small parts which can be swallowed by children and pets. Keep children and pets away during assembly. To avoid danger of suffocation, always keep plastic bags away from children and pets.

We recommend that you assemble this unit on a carpeted floor to avoid scratches. If using power tools, set the tool to low torque to avoid damage.

May require 2 people for ease of assembly.

Care & Maintenance

This furniture is designed for indoor use.

Damage to furniture can come from temperature changes in relative humidity (RH) in our homes. Humid air oxidizes metal which results in rusting, corrosion, tarnishing and roughness. Wood absorbs water as relative humidity rises and falls, and in doing so it swells and shrinks.

To protect against the humidity effect, the metal is powder coated. The powder coat layer protects the metal from oxidizing, corrosion, tarnishing and scratching and keeps it looking good for years to come. The wood is sealed and lacquered to protect against humidity.

To help protect your furniture, follow these steps:

- Use a humidifier, preferably one with an automatic control system that can sense the humidity level and adjust itself accordingly
- Dust with soft dry cloth
- Wipe up spills promptly
- Clean with a dry cloth
- Do not use abrasive cleaners, chemical solvents, strong detergents, cleaners with bleach, and furniture polish
- Use soft felt base coasters, placemats to help prevent scratches
- Keep furniture out of direct sunlight, which can cause cracking or roughness on the protective layer
- If it can be avoided, do not put furniture near heating vents
- Keep the furniture 3 to 4 inches away from the wall, giving heat and air space to circulate

Part Description

A

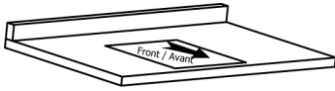

SHELF
QTY 1

B

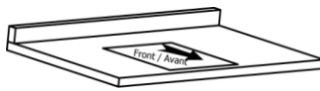

SHELF
QTY 1

C



SHELF
QTY 1

DR

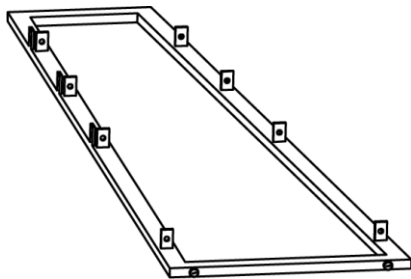

RIGHT SIDE
QTY 1

DL

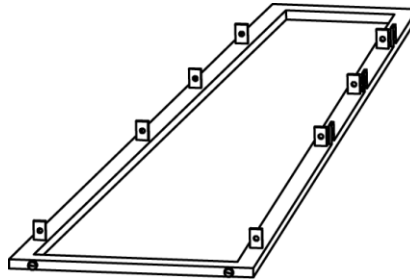

LEFT SIDE
QTY 1

E

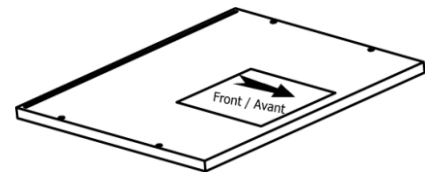

TOP CABINET SHELF
QTY 1

FR

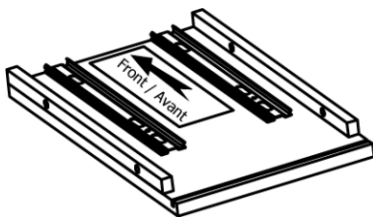

RIGHT SIDE CABINET PANEL
QTY 1

FL

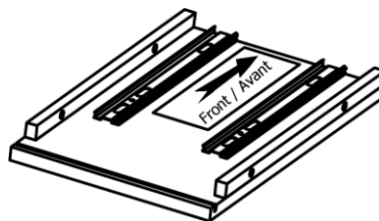

LEFT SIDE CABINET PANEL
QTY 1

G

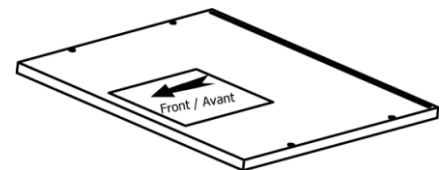

BOTTOM CABINET SHELF
QTY 1

Part Description

H

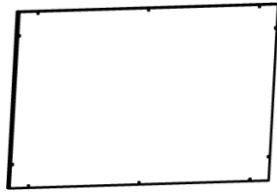

BACK PANEL
QTY 1

I

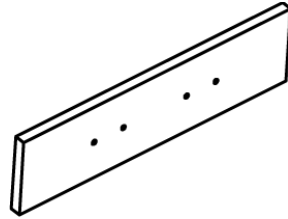

DRAWER FACE
QTY 2

JL

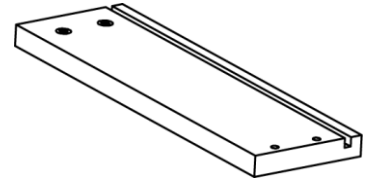

LEFT DRAWER SIDE
QTY 2

JR

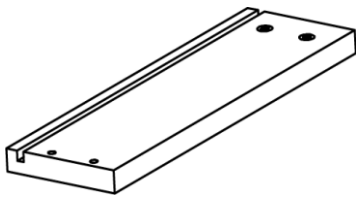

RIGHT DRAWER SIDE
QTY 2

K

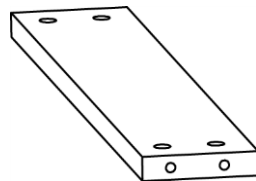

DRAWER BACK
QTY 2

L

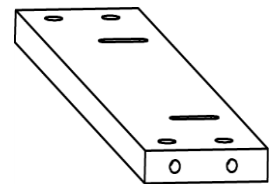





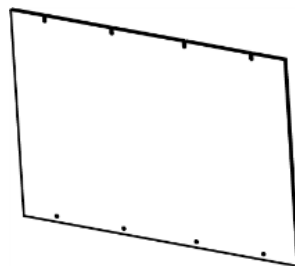





DRAWER FRONT
QTY 2

M

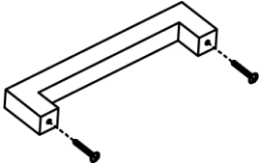
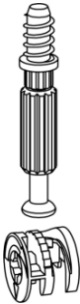
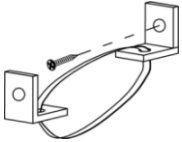

DRAWER BOTTOM
QTY 2

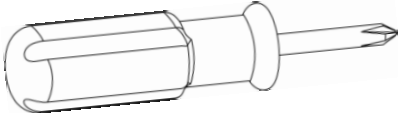
Hardware Description

| | | | |
|---|--|---|---|
| <p>1</p>  <p>ALLEN KEY BOLT M6 x 20 mm QTY 22</p> | <p>2</p>  <p>WASHER Ø20 / Ø9 x 3 mm QTY 34</p> | <p>3</p>  <p>ALLEN KEY BOLT M6 x 40 mm QTY 12</p> | <p>4</p>  <p>ALLEN KEY 4 mm QTY 1</p> |
| <p>5</p>  <p>LOCK WASHER Ø15 / Ø9 x 2 mm QTY 22</p> | <p>6</p>  <p>SCREW M4 x 20 mm QTY 26</p> | <p>7</p>  <p>WASHER Ø10 / Ø5 x 1.5 mm QTY 26</p> | <p>8</p>  <p>HANDLE M4 x 50 mm 2 SETS</p> |
| <p>9</p>  <p>CAM LOCK M6 x 40 mm QTY 16 SETS</p> | <p>10</p>  <p>FURNITURE TIP OVER RESTRAINT QTY 2 SETS</p>  <p>M4 x 20 mm QTY 2</p>  <p>M4 x 30 mm QTY 2</p> <p>Required Phillips screwdriver Not Included</p>  | |  <p>M4 x 40 mm QTY 2</p> |

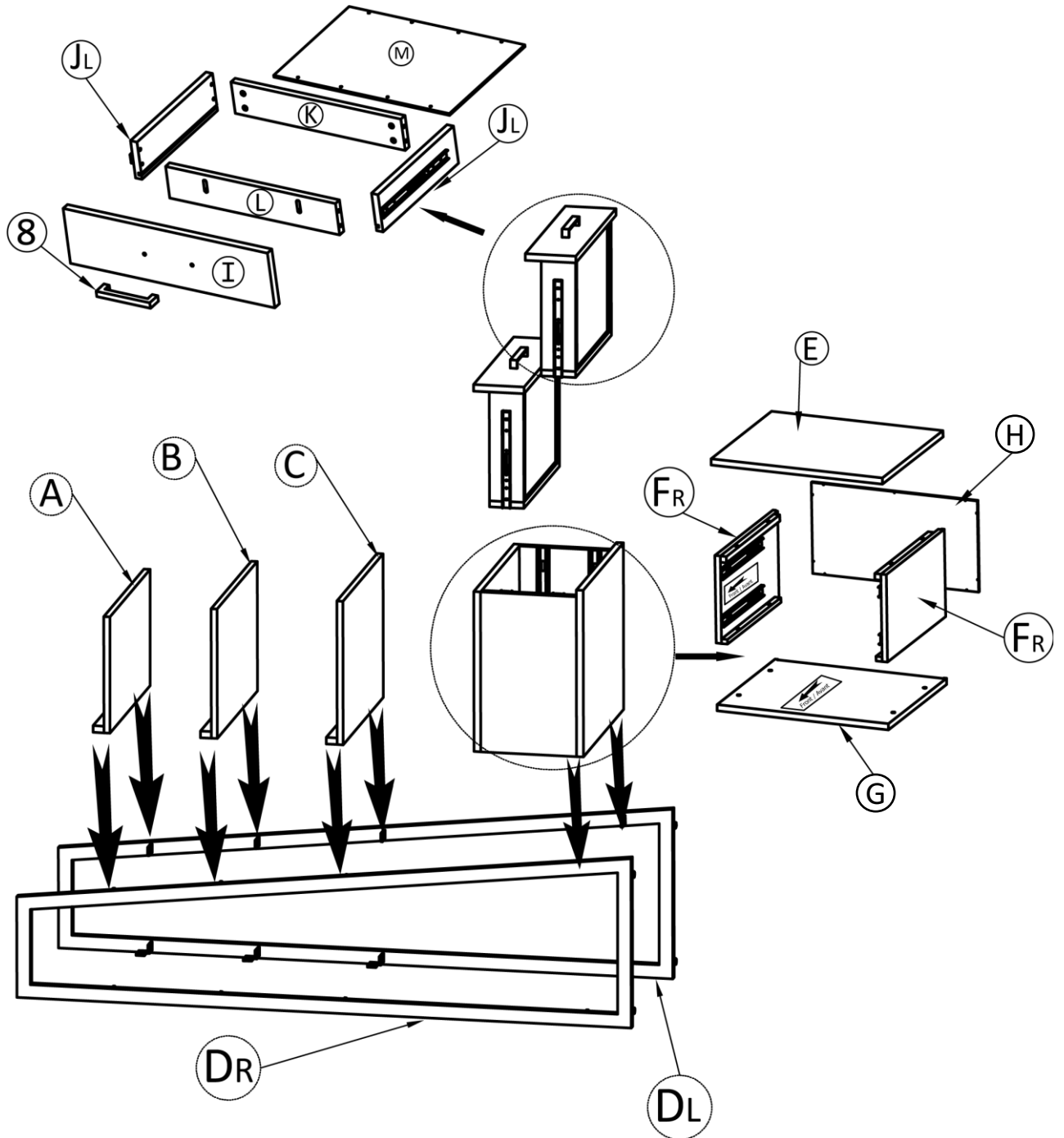

Step 1

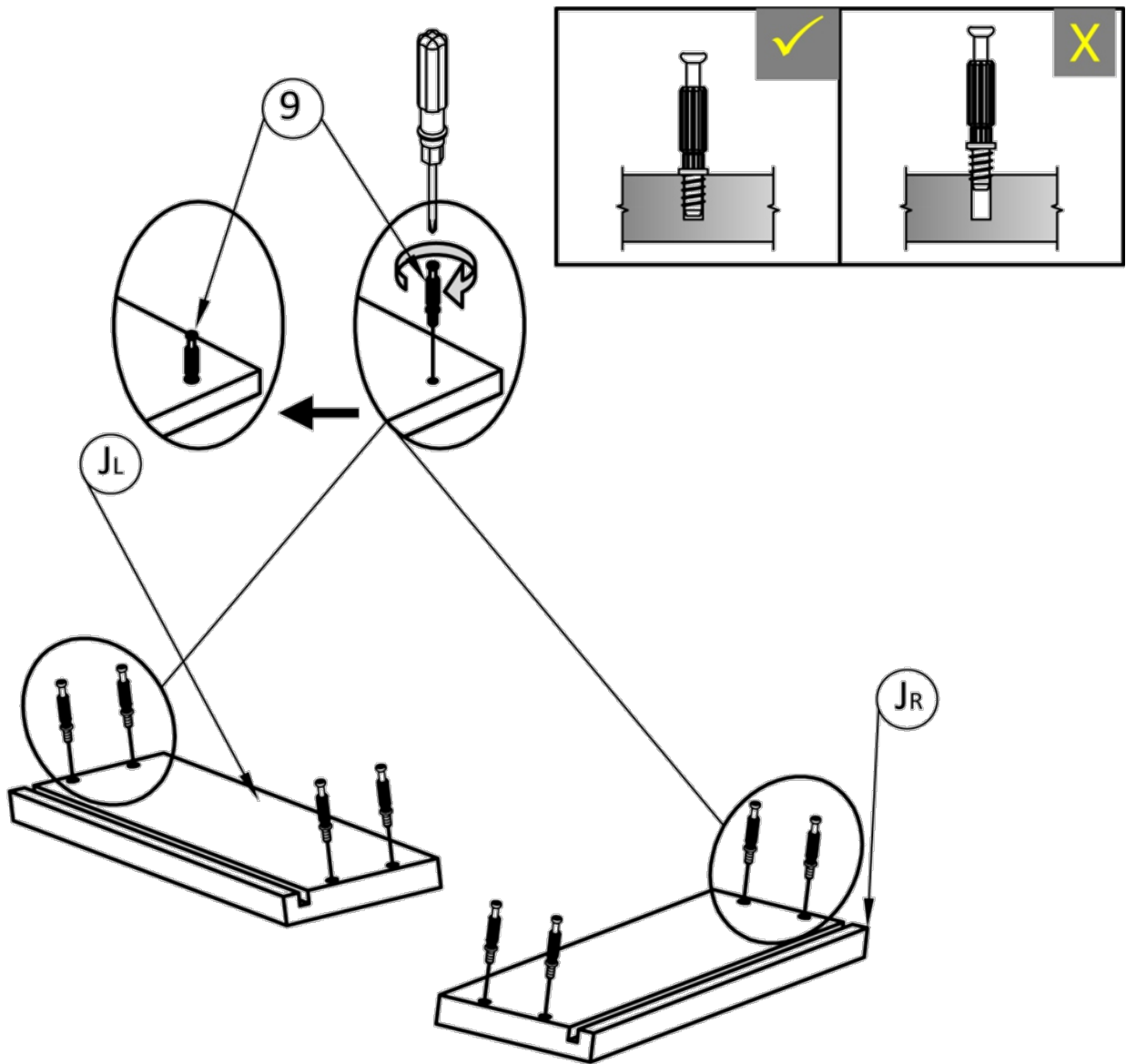

1. Insert Cam Locks (9) to Drawer Sides (JR) and (JL)
2. Use Screwdriver to tighten the Cam Locks (9).

Step 2

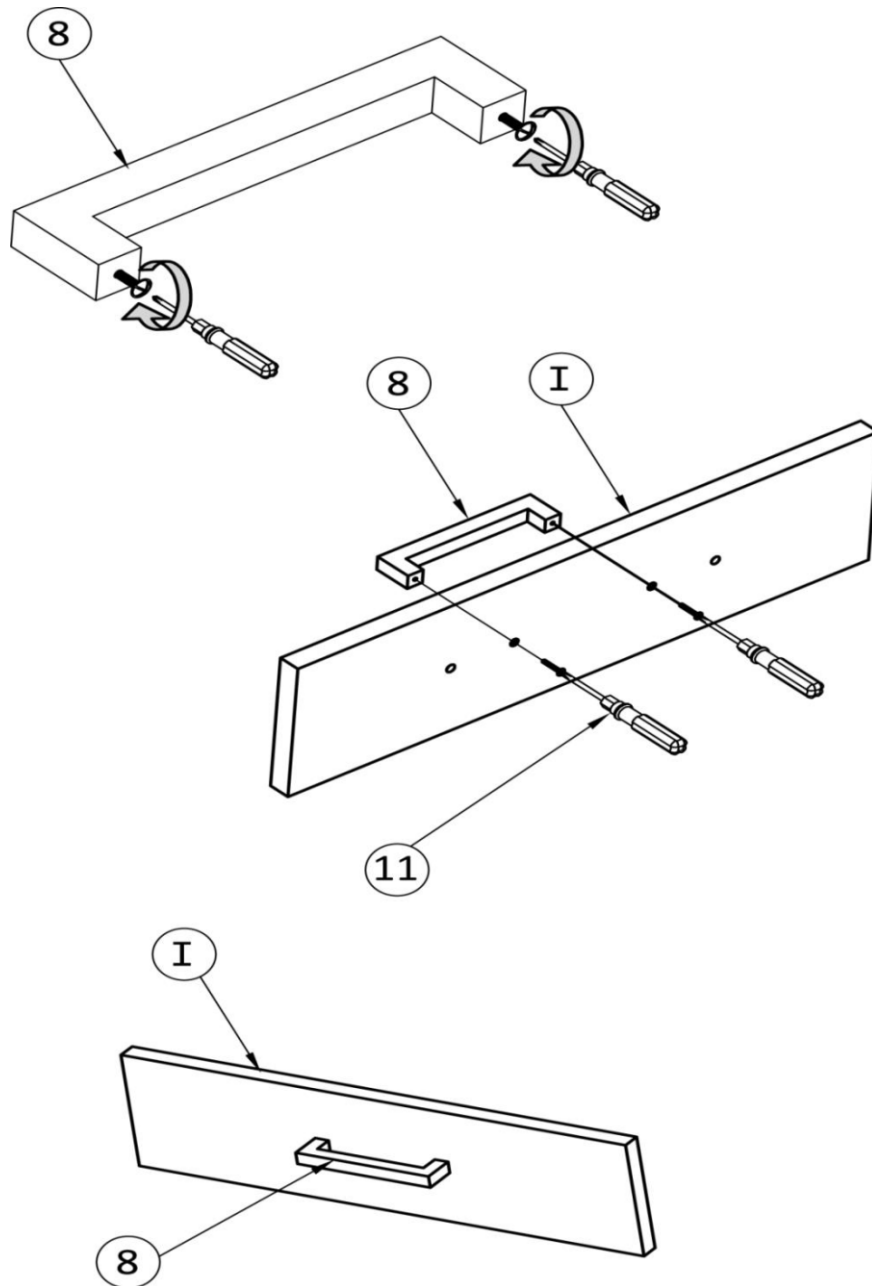

1. Attach the Handle (8) to the Drawer Face (1) using the Handle screws (8).
2. Use a Screwdriver to tighten screws.

Step 3

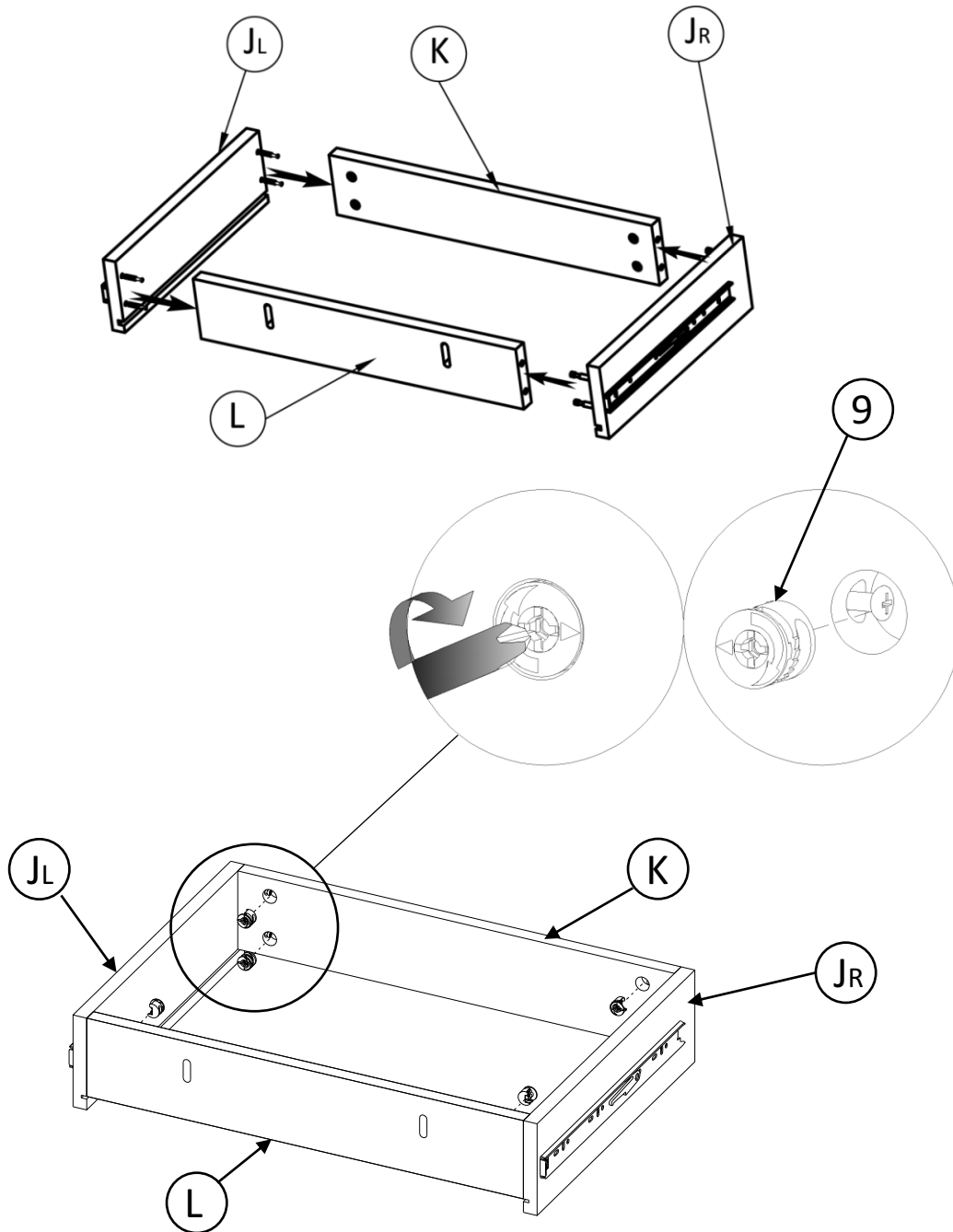

1. Attach Drawer Sides (JL) and (JR) to Drawer Front (L) and Drawer Back (K) with Cam Locks (9).
2. Use Screwdriver to lock Cam Locks (9) in place.

Step 4

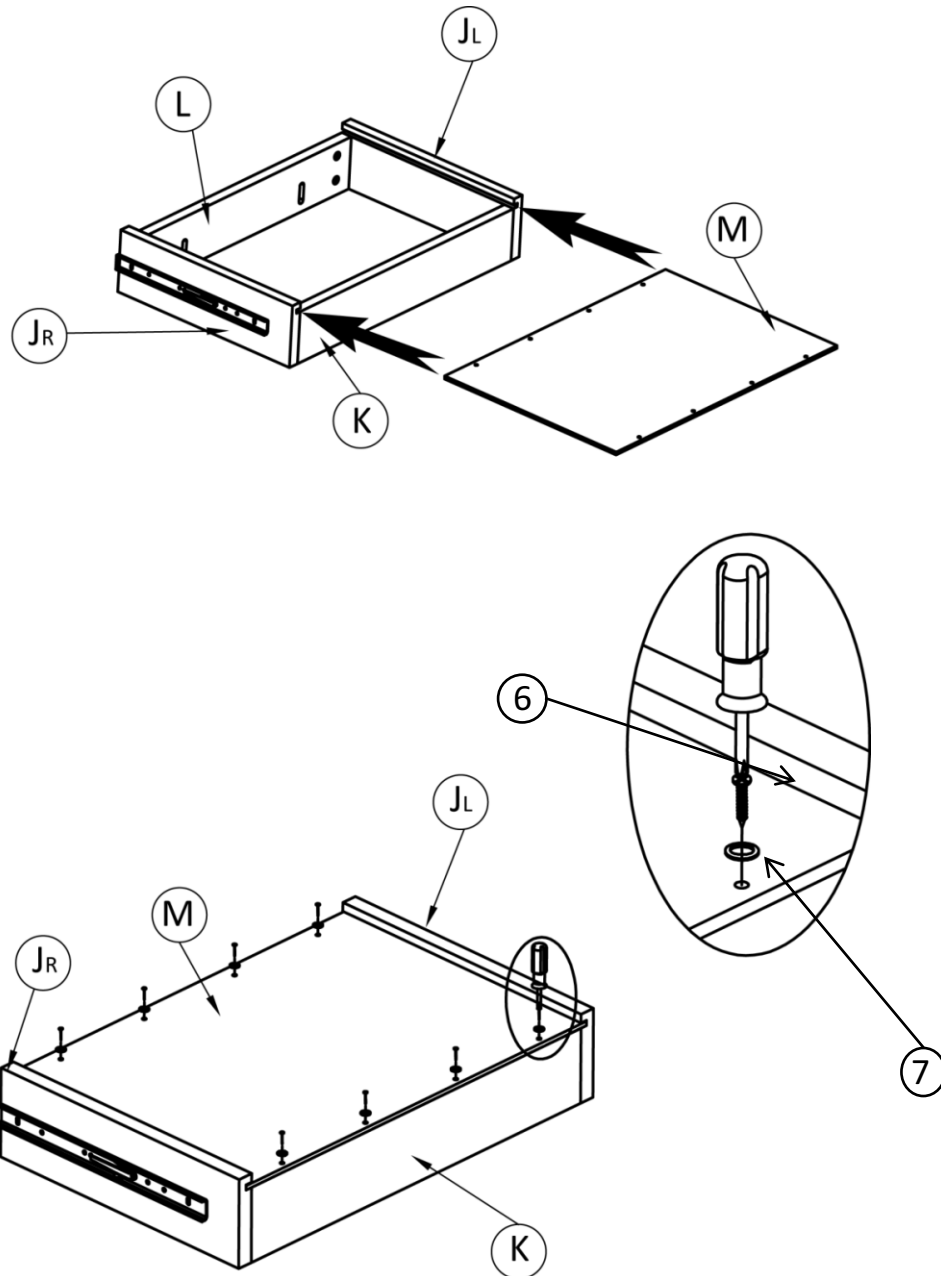

1. Attach Drawer Sides (JL) and (JR) to Drawer Bottom (L) using Screws (6) and Washers (7).
2. Use Screwdriver to tighten Screws (6).

Step 5

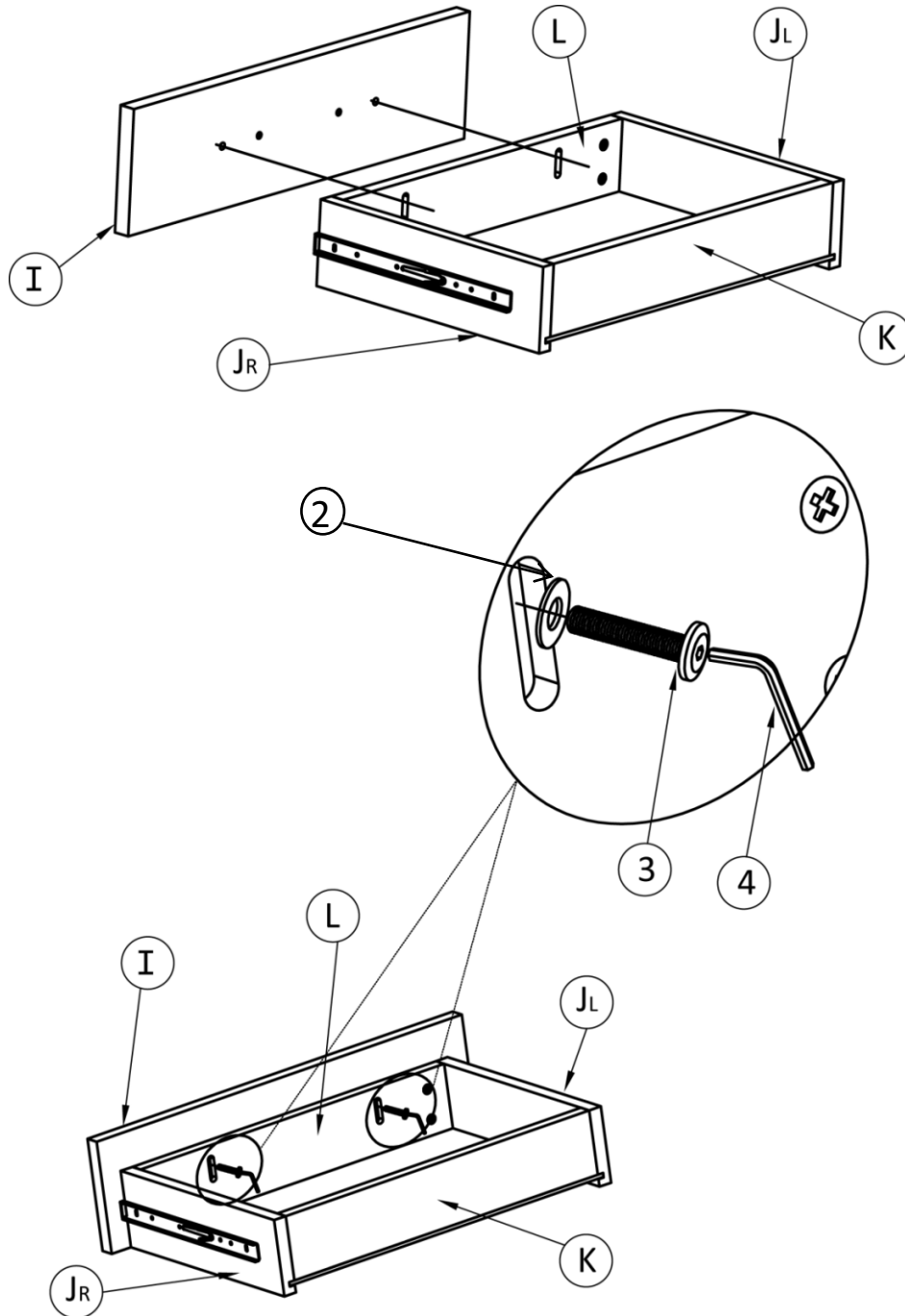

1. Attach Drawer Face (I) to Drawer Front (L) using Allen Key Bolts (3) and Washers (2).
2. Use Allen Key (4) to tighten Bolts.

Step 6

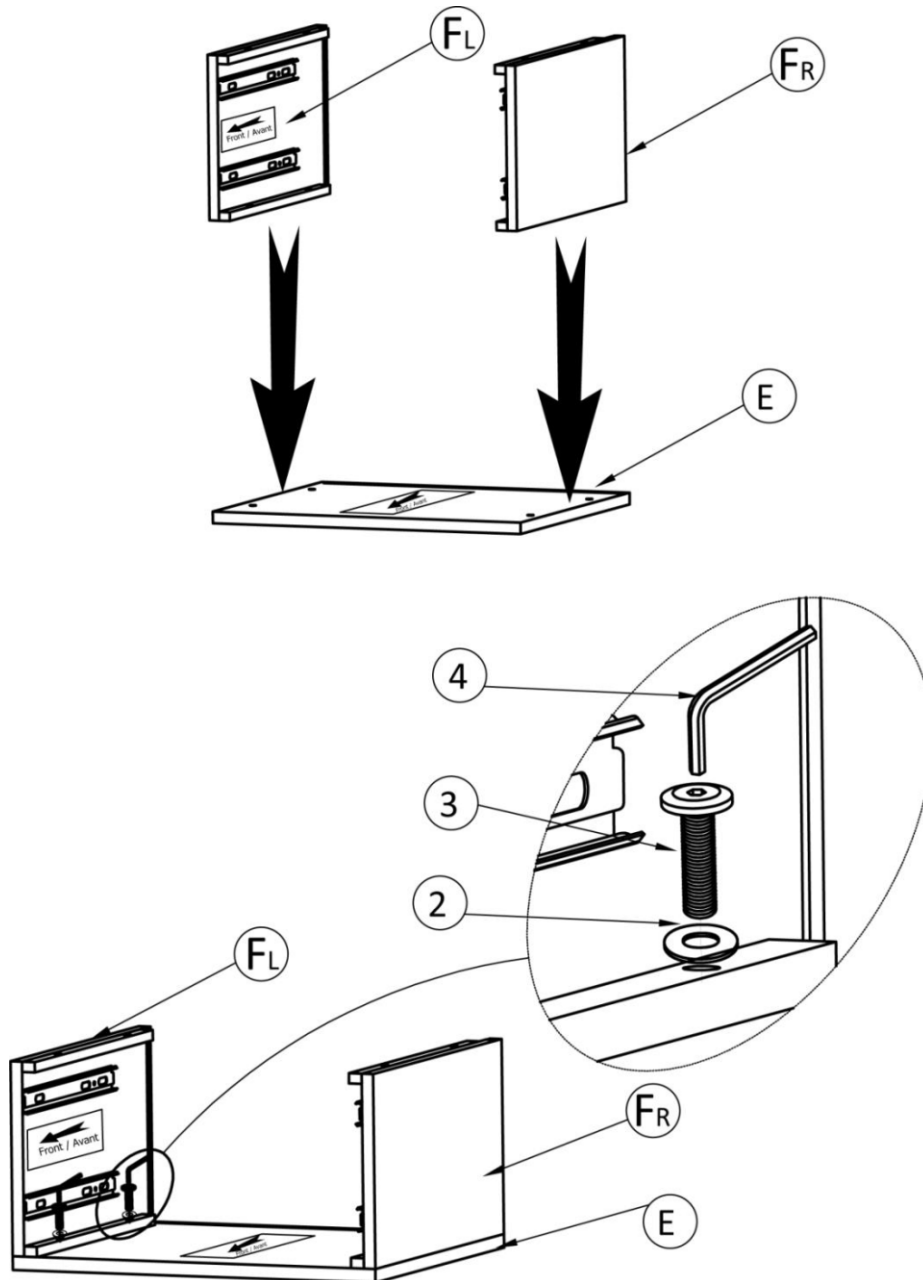

1. Attach Top Cabinet Shelf (E) to Cabinet Panels (FL) and (FR) using Allen Key Bolts (3) and Washers (2). Do not over tighten Bolts.
2. Use Allen Key (4) to tighten Bolts (3).

Step 7

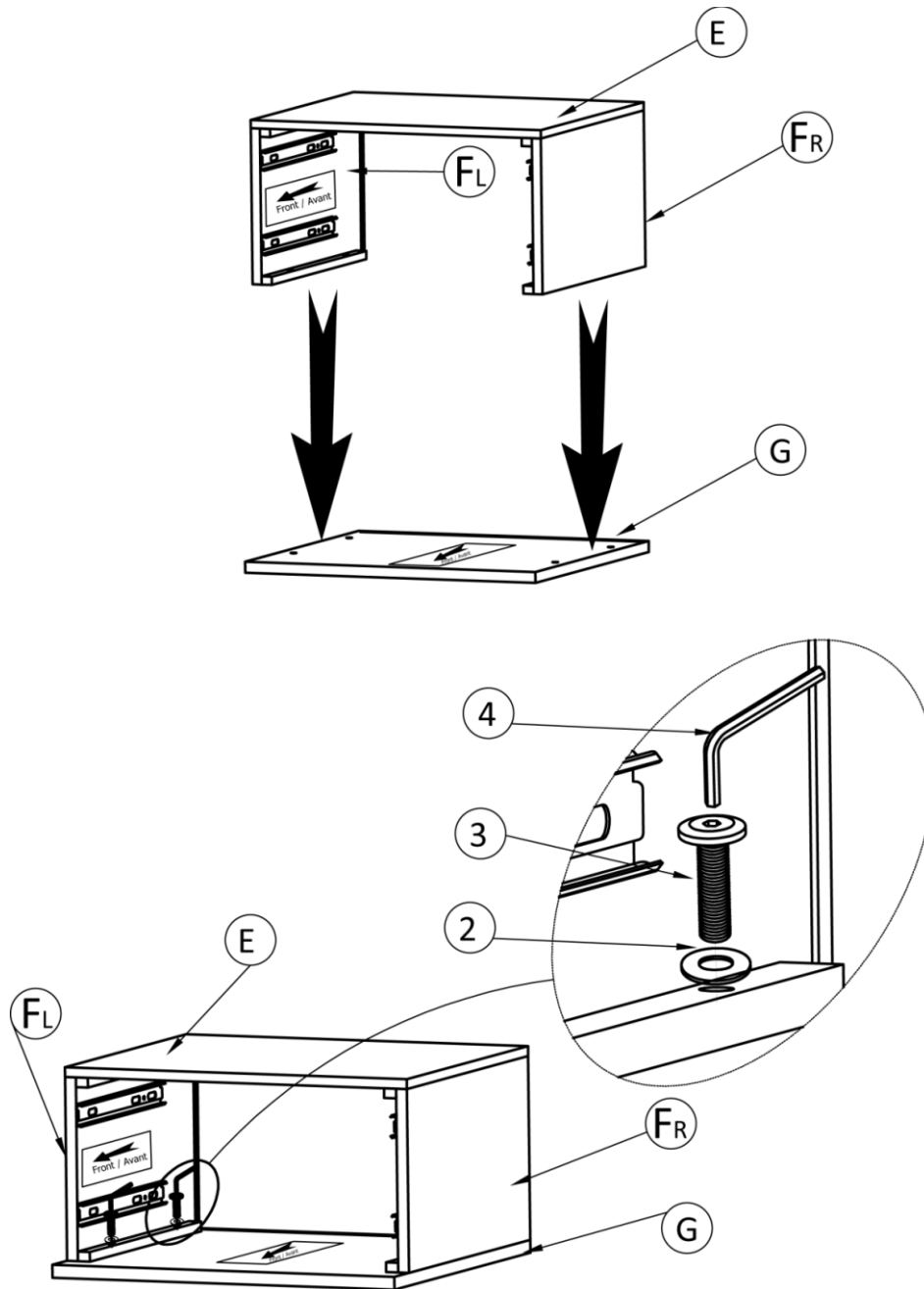

1. Attach Cabinet Panels (FL) and (FR) to Bottom Cabinet Shelf (G) using Allen Key Bolts (3) and Washers (2)
Do not over tighten Bolts.
2. Use Allen Key (4) to tighten Bolts

Step 8

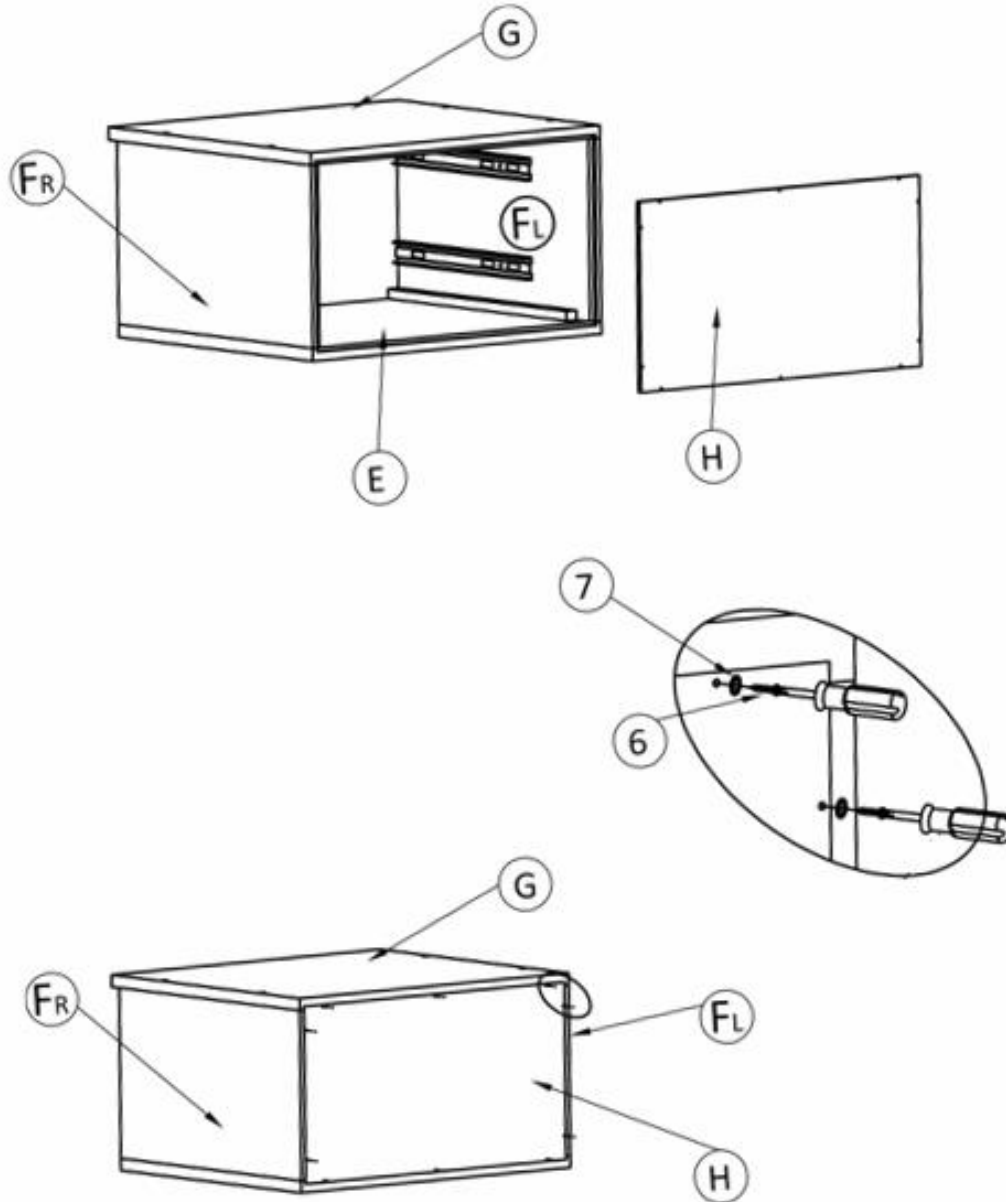

1. Attach Cabinet Panels (FL) and (FR) to Bottom Cabinet Shelf (G) and Top Cabinet Shelf (E) to Storage Back (H) Using Screws (6) and washers (7).
2. Use Screwdriver to tighten Screws (6).

Step 9

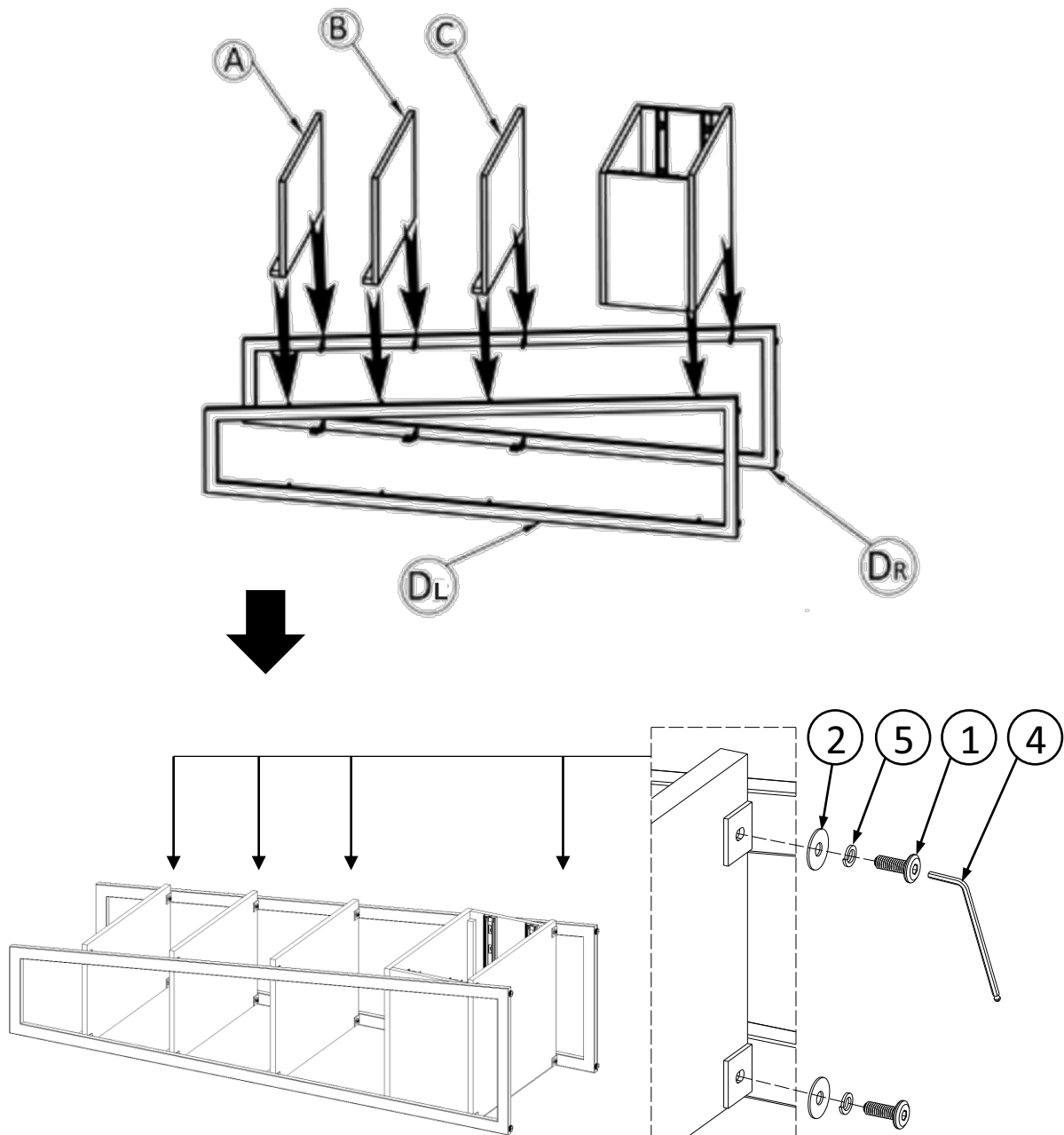

1. Align Sides (DL) and (DR) with Shelf (A), (B) and (C).
2. Align assembled Cabinet with Sides (DL) and (DR).
3. Use Allen Key Bolts (1), Lock Washers (5) and Washers (2) to secure parts (A), (B), (C) Cabinet and Legs (DL), (DR).
4. Use Allen Key (4) to tighten Bolts.

Step 10

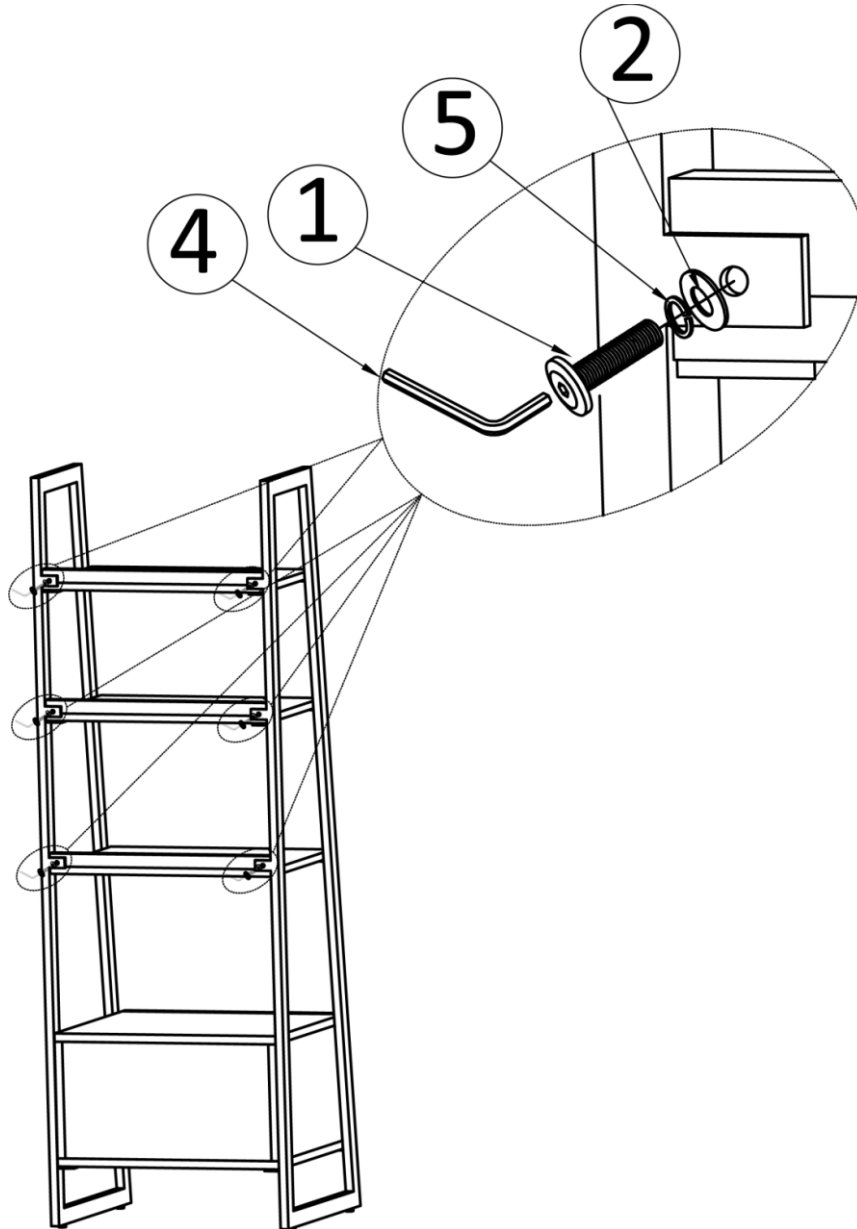

1. Align Sides (D_L) and (D_R) to Shelf (A), (B) and (C) using Allen Key Bolts (1), Washers (2) and Lock Washers (5).
2. Use Allen Key (4) to tighten Bolts.

Step 11

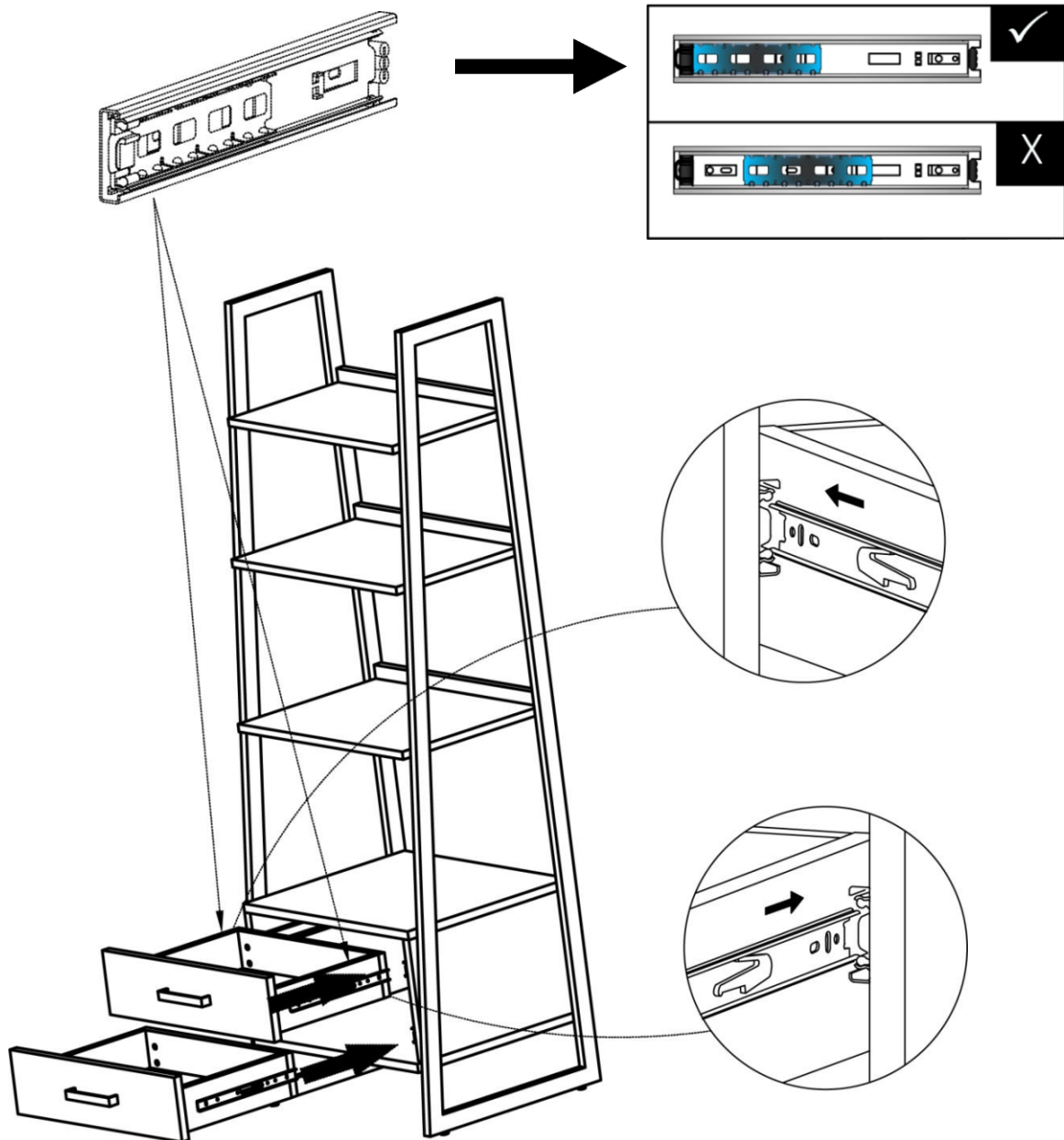

I. Insert the assembled drawers in the Cabinet.

Step 12

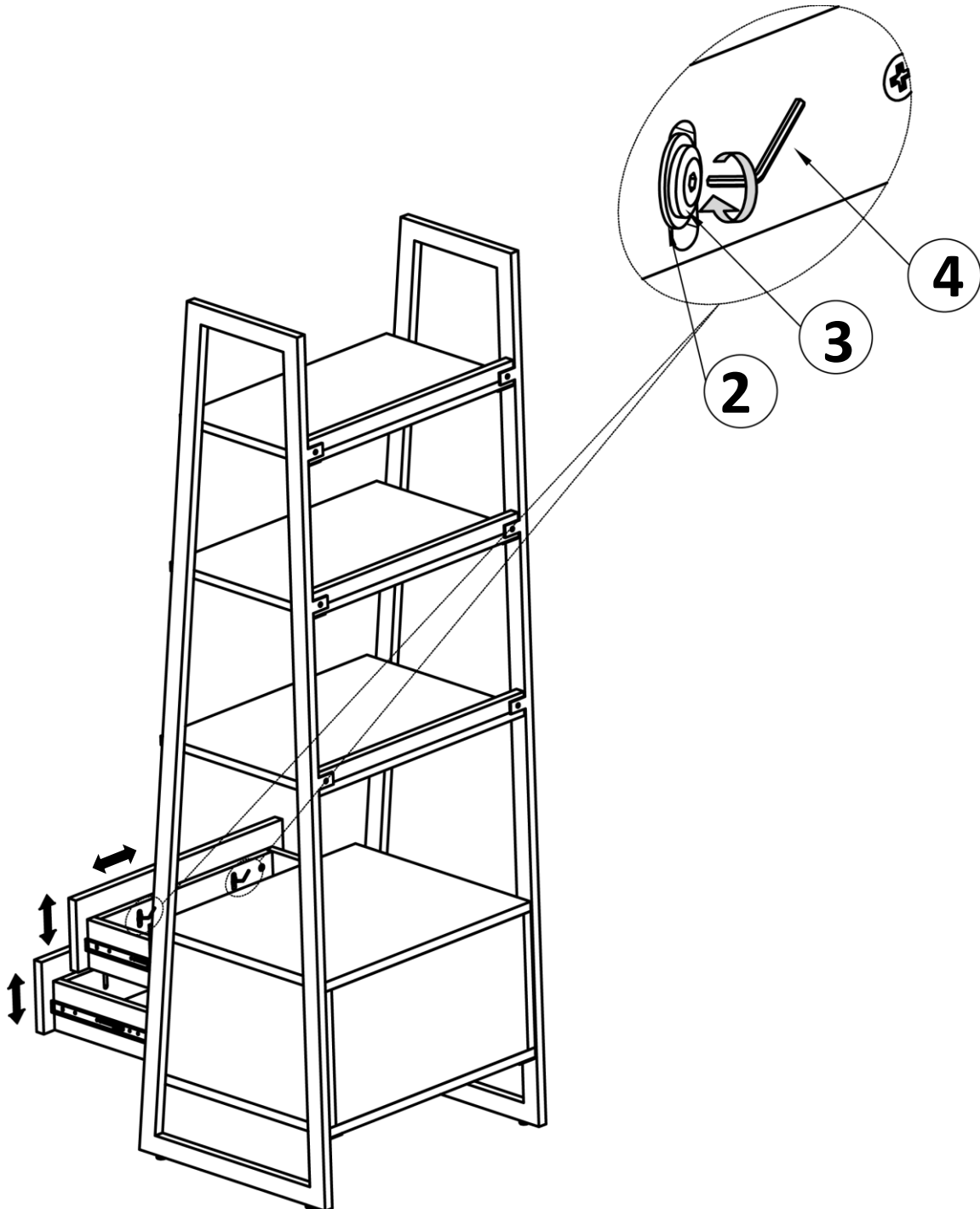

I. Adjust the Drawer Face ① using Allen Key ④.

Step 13

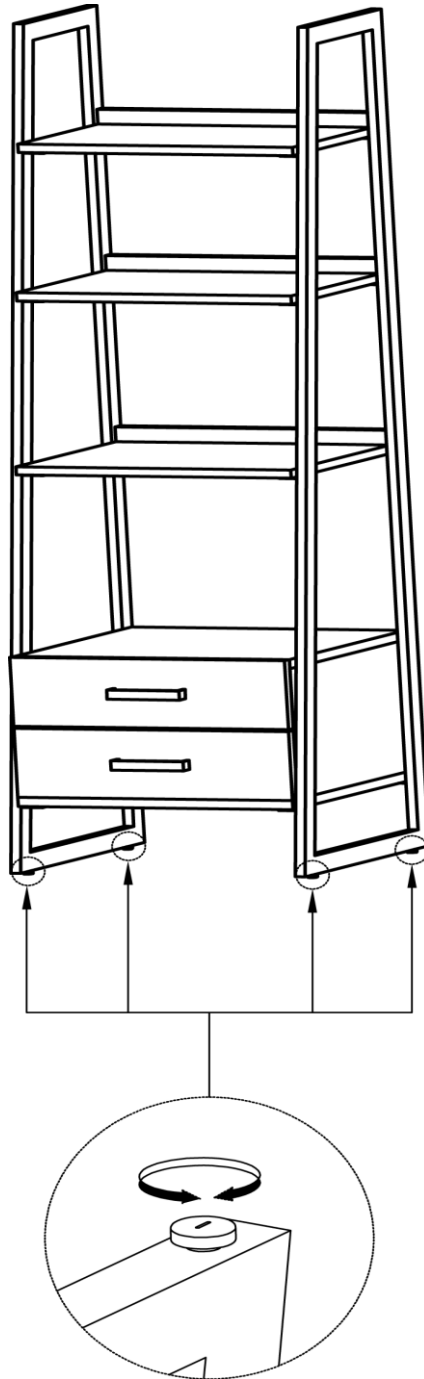

Note: Levelers on the bottom of the Sides can be adjusted if floor is uneven.

FURNITURE ANTI-TIPPING RESTRAINT INSTRUCTIONS

WARNING

Serious or fatal crushing injuries can occur from furniture tip-over.
If the furniture tip over restraint kit is not in the box, please contact our customer service department in order to obtain another kit before using the furniture.

Step 14

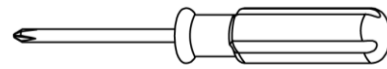

NOTE : - The screwdriver is not included in the hardware pack

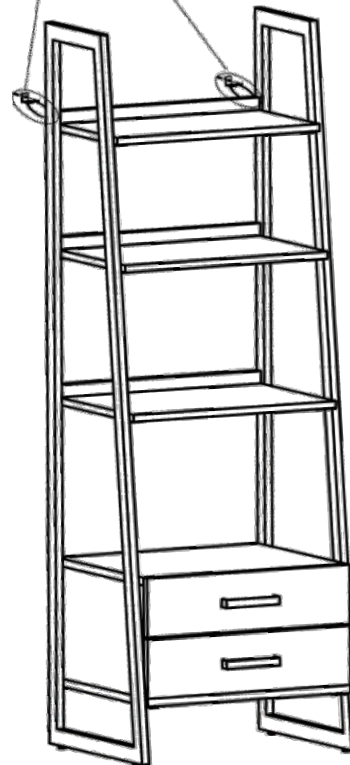
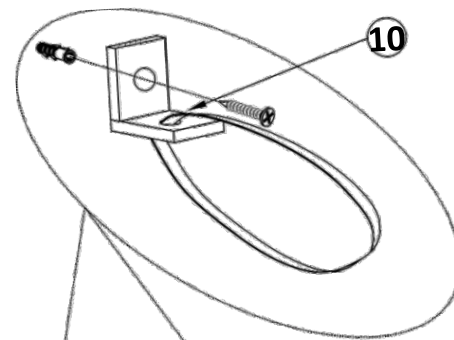
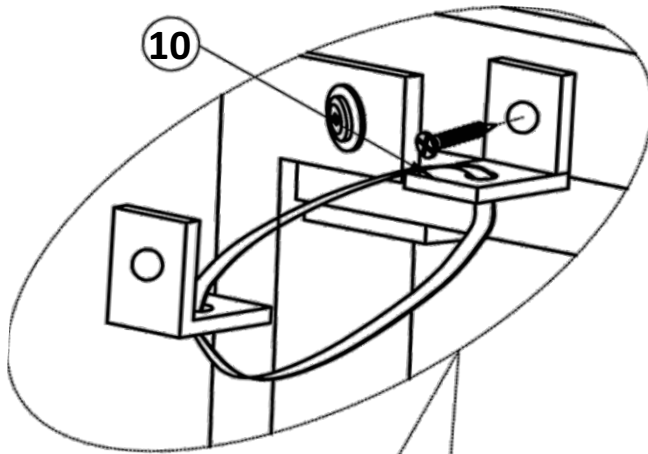

FURNITURE ANTI-TIPPING RESTRAINT INSTRUCTIONS

1. Attach one of the mounting brackets securely to the back edge of the furniture. Use the shorter screw.

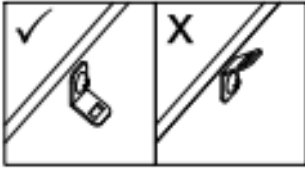

2. Determine where furniture is to be placed and mark location on the wall for mounting bracket screw hole approximately 2 inches below the bracket mounted to the furniture.

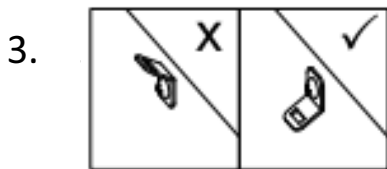

4. Drill a 3/16 inch hole in the wall. Press the plastic anchor into the hole and gently tap until the flange on the anchor is against the wall surface.
5. Position the bracket over the anchor and use the longer screw to securely attach the bracket to the wall.
6. Place the furniture so the back edge is in line with the bracket on the wall.
7. Lace an end of the nylon zip-tie strap down through each bracket. Bring both ends together and slide the smooth side upright through the square-shaped end and pull through to create the "locked" position.
8. Check to make sure the strap is securely laced and locked to the brackets.

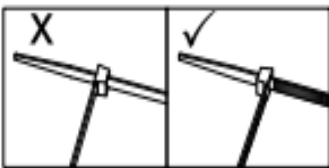

- **DO NOT** put a TV or other heavy objects on top of furniture not intended for use with a TV
- **DO NOT** place heavy objects in top drawers or on top shelves
- **DO NOT** let children climb or hang on drawers, doors or shelves