

|  |        |
|--|--------|
| SIDES  | BOTTOM |
|  |        |
|  |        |
| Material: Steel- $\varnothing$ 0.16"-(C1008-C1018) Zinc Plated |        |

$\begin{matrix} +0.02 \\ \varnothing 4.06-0.06 \end{matrix}$ 
 $\left[ \begin{matrix} +0.0008 \\ \varnothing 0.160-0.0024 \end{matrix} \right]$

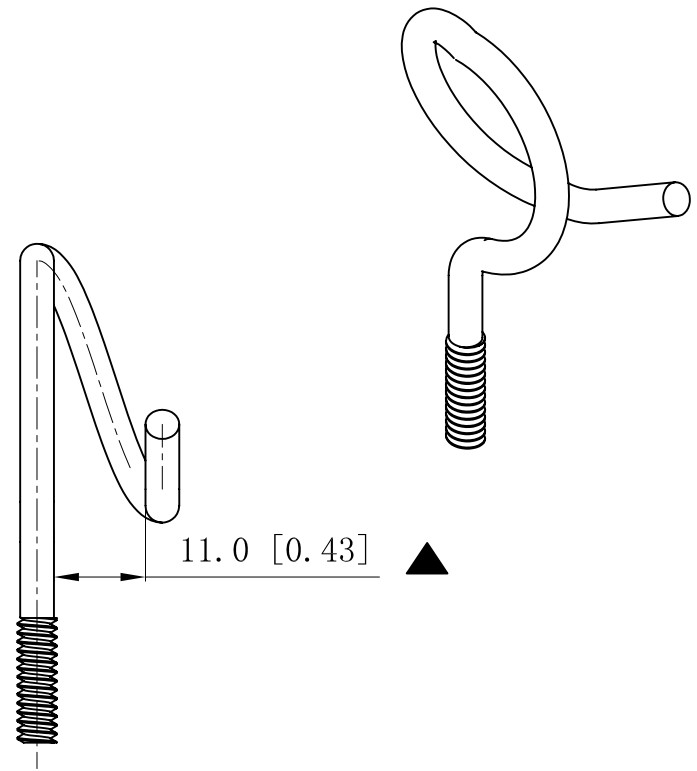
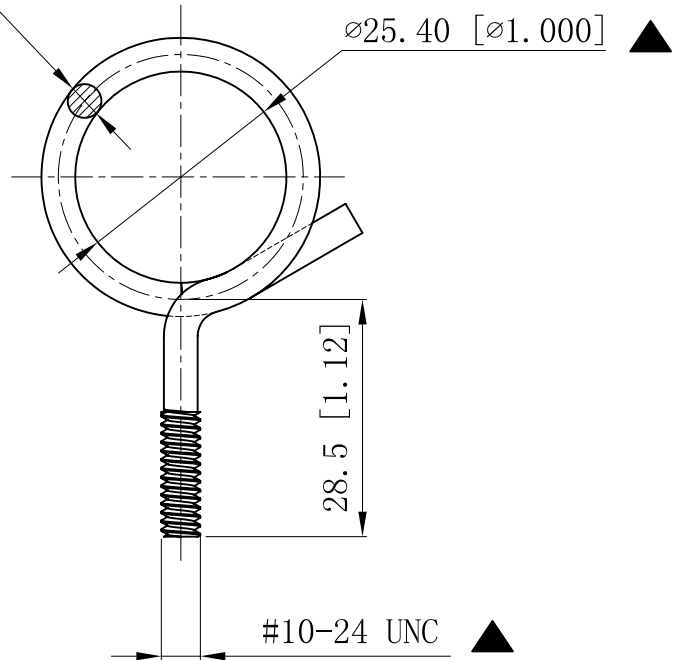

This data sheet is for reference only .GARVIN INDUSTRIES reserves the right to make changes to the design without prior notice.

|                       |
|-----------------------|
| DESCRIPTION           |
|                       |
| TRADE REFERENCE TERMS |
|                       |

|                  |
|------------------|
| STANDARD PACKING |
| 100 PCS          |

|                                    |                       |     |
|------------------------------------|-----------------------|-----|
| <b>GARVIN INDUSTRIES</b>           |                       |     |
| TITLE<br>MACHINE-SCREW BRIDLE RIGS |                       |     |
| SIZE<br>A4                         | DWG NO.<br>BR-1001024 | REV |
| DATA SHEET                         |                       |     |