

# Saramonic

Sound.Remarkable. 

## 2.4GHz Dual Wireless Lavalier System **SR-WM2100**

User Manual

Thank you for choosing Saramonic!

The Saramonic SR-WM2100 is a compact dual channel 2.4GHz wireless lavalier microphone system intended for portable operation. Ideal for DSLR, Mirrorless and video cameras as well as smartphones and tablets for broadcast TV, electronic news gathering (ENG), on-the-spot interviews and more. With an operating range of up-to 70m in open areas.

## Statement

Please read this manual carefully before using and strictly operate and store in accordance with the instructions. Please save it for your future reference.

If the user manual can not help you to solve certain problems, please ask your retailer for help or email us: **[info@saramonic.com](mailto:info@saramonic.com)**.

# Portable Receiver SR-WM2100 RX

## Introduction

The SR-WM2100 RX is a camera-mountable wireless receiver. It features level control, headphone monitoring, automatic pairing with transmitters, and two output cables, TRS for video cameras and TRRS for mobile devices.

Equipped with an auto-scan function, the RX can automatically search for an available transmission frequency with the best signal.

## Product Structure

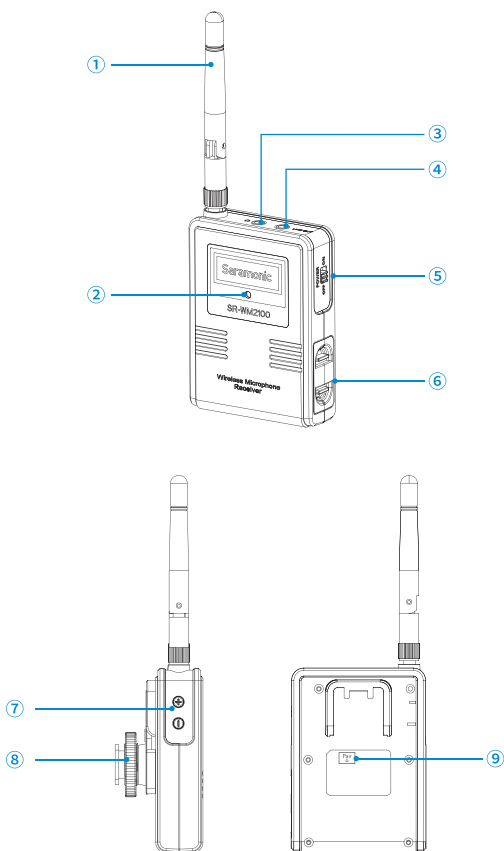

① **Antennas**

Screw clockwise to install.

Screw counterclockwise to dismantle.

Adjust the antenna accordingly to get the best sound reception.

Please do not touch the antenna during recording to avoid interfering with the signal.

② **LED indicator**

Status	Both transmitter TX and receiver RX
Turn on the TX / RX	Quick flashing green light ( every one second)
TX & RX pairing successfully	Flashing green light (every 2.5 seconds)
Low battery level	Flashing red light

③ **Headphone jack**

3.5mm stereo mini headphone jack.

Connect headphones to monitor the audio output.

**Note:** Please do not connect a headphone with a monaural mini jack. As this may short-circuit the headphone jack and distorted sound output.

④ **Line out jack**

1-Connect the RX receiver to a video camera, camcorder, audio recorder or mixer with the supplied 3.5mm TRS output cable.

2-Connect the RX receiver to a smartphone or tablet with the supplied 3.5mm TRS to TRRS (CTIA standard) output cable.

⑤ **Power button (OFF/ON switch)**

Slide the power button to ON, turn on the RX receiver.

Slide the power button to OFF, turn off the RX receiver.

⑥ **Battery compartment**

Operates on two AA batteries (not included).

⑦ **+ or - button**

Audio output level controls.

The setting is retained even after the power is turned off.

⑧ **Standard cold shoe mount**

⑨ **Pairing pinhole**

## Attaching Accessories

### 1. Connect the supplied cable to the line output jack

- When connecting to a DSLR, Mirrorless camera, camcorder, audio recorder or mixer, please use the 3.5mm TRS output cable. Plug one end into the line output jack of the receiver and plug the other end into the mic input jack of the camera.

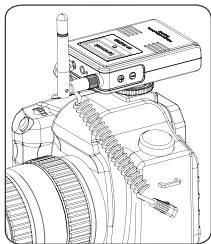
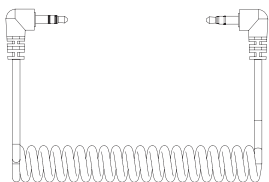

- When connecting to a smartphone or tablet, please use the 3.5mm TRS to TRRS (CTIA standard) output cable. Plug the 90 degree right angle TRS into the line output jack of the receiver and plug the straight TRRS end into the 3.5mm headphone jack of a smartphone or tablet.

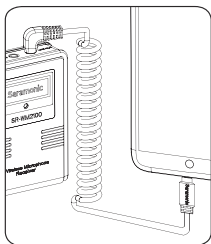
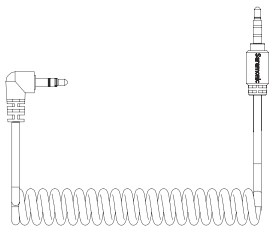

## 2. Attach the shoe-mount adapter

Attach the shoe mount adapter to the receiver, and secure it on your camera's hot shoe or rig.

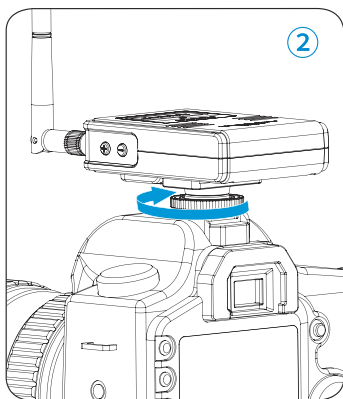
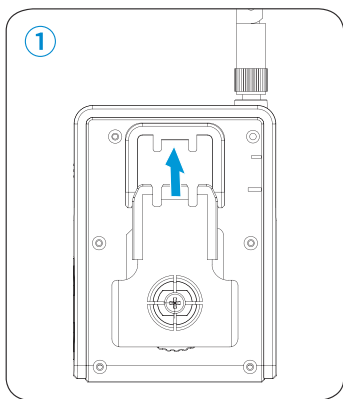

# Portable Transmitter SR-WM2100 TX

## Introduction

The SR-WM2100 TX is a compact wireless belt pack transmitter that features both Mic and Line input connectors, foldable antenna for best possible wireless transmission and automatic pairing with receiver.

## Product Structure

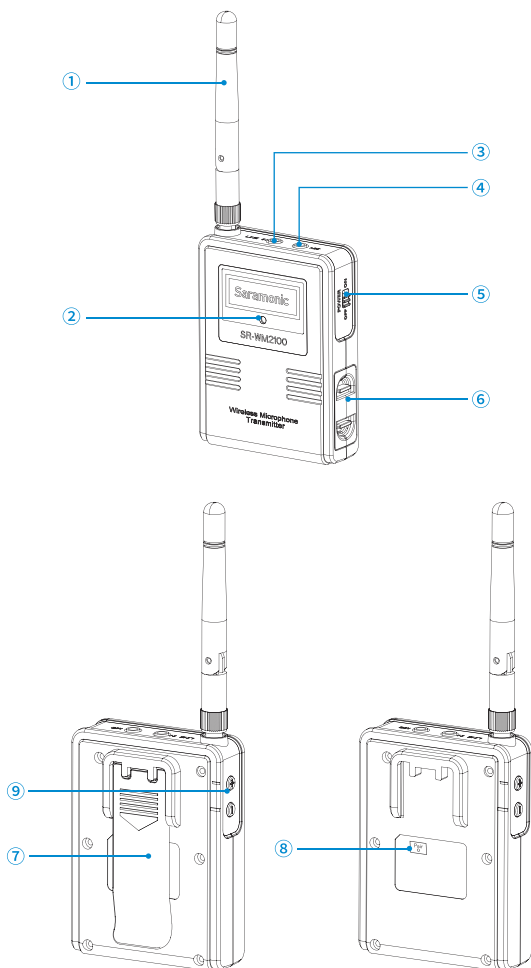

① **Antennas**

Screw clockwise to install.

Screw counterclockwise to dismantle.

Adjust the antenna accordingly to get the best sound transmission.

Please do not touch the antenna during recording to avoid interfering with the signal.

② **LED indicator**

Status	Both transmitter TX and receiver RX
Turn on the TX / RX	Quick flashing green light ( every one second)
TX & RX pairing successfully	Flashing green light (every 2.5 seconds)
Low battery level	Flashing red light

③ **Line input jack**

Connect to audio devices with line output.

④ **Mic input jack**

Connect to the supplied 3.5mm lavalier microphone.

⑤ **Power button (OFF/ON switch)**

Slide the power button to ON, turn on the TX transmitter.

Slide the power button to OFF, turn off the TX transmitter.

⑥ **Battery compartment**

Operates on two AA batteries (not included).

⑦ **Belt clip**

⑧ **Pairing pinhole**

⑨ **+ or - button**

Audio level controls.

The setting is retained even after the power is turned off.



## Attaching Accessories

### 1. Connect the microphone

Connect the supplied 3.5mm lavalier microphone into the mic input jack, or connect audio device's line output into the 3.5mm line input jack of transmitter.

**Note:** Please turn off the transmitter before connecting or removing the microphone.

### 2. Clip the transmitter on your belt, or put it in your pocket.

## Operation Guide

### 1. Install the batteries

**Transmitter TX and Receiver RX both need two AA size batteries.**

- Slide the two catches inward and pull out the battery compartment.
- Insert two AA size batteries according to the polarity indicators and close the compartment.  
Please make sure the battery compartment is locked securely.



#### **Cautions on battery use**

Please make sure to follow the several points when install batteries:

- Make sure the batteries are inserted correctly according to the polarity indicators.
- It is suggested to replace both batteries at the same time.
- Please do not use two batteries from different brands together as a combination.
- Remove the batteries from the battery compartment when the device is not used for an extended period of time.

### 2. Slide the power button to ON, turn on both the transmitter and receiver.

### 3. Transmitter and Receiver pairing

- Pull off the belt clip, as image below illustrates, and you will notice the pairing pinhole on both transmitter and receiver.

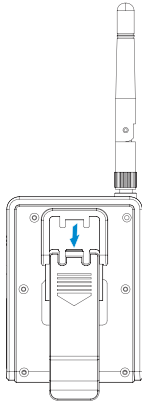

- Using the supplied pairing pin, insert into the small pinhole on both transmitter and receiver in quick succession. When pairing is successful, the indicators flash in green slowly, about every 2.5 seconds.
- The other transmitter can easily be paired with the receiver using the same method.

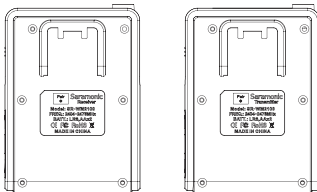

**Note:** The system is already paired at the factory and will be paired when it is turned on. Additionally, it will automatically search for an available transmission frequency with the best signal.

**4. Connect the receiver to the mic input of a camera, camcorder, mixer, smartphone or tablet with one of the supplied output cables.**

**5. Plug headphones into the receiver to monitor the recording audio if your camera or device lacks a headphone output.**

**Note:** If headphones are connected successfully, the indicator flash slowly in green every 2.5 seconds. Otherwise, the indicator flash quickly in green, please ensure headphones are fully plugged into the phone jack.

**6. Attach the accessories you need for the receiver and transmitter, refer to “attaching accessories” on Page 5-6 and Page 9.**

**7. You are ready to record.**

**Notice:** Due to 2.4GHz wireless frequency, signal can be easily attenuated. Please try to avoid obstacles, such as walls and buildings, and avoid close proximity to devices with 2.4GHz signal, such as high-power WiFi antennas, smartphones with WiFi in use, radios, etc.

## Specification

Oscillator type	GFSK
Carrier frequencies	2.4GHz (2404-2476MHz)
Antenna	2.4GHz built-out antenna
Frequency response	35Hz-14kHz (+/-3dB)
Signal to noise ratio	75dB or more
Polar pattern of lavalier microphone	Omni-directional
Reference deviation	10ppm
Distortion	0.05% or less (32Ω, 1 kHz, 65mW output)
Receiver sensitivity	-87dBm
RF output power	5mW
Headphone output level	65mW (32Ω)
Reference audio input level	-30~-42dBv (MIC input, 0dB attenuation)
Audio input connectors	3.5mm mic input
	3.5mm line input
Headphone output connector	3.5mm mini jack
Operating Distance	70m (without obstacle)
Battery	Two AA size batteries
Approximate Battery Life	≥ 20 hours
Dimensions	TX: 62.5*85.7*26.4 mm
	RX: 62.5*85.7*26.4 mm

Weight	TX: 68g (2.40oz) (without batteries)
	RX: 68.5g (2.42oz) (without batteries)
Operating temperature	0°C to 50°C
Storage temperature	-20°C to +50°C

## Packing list

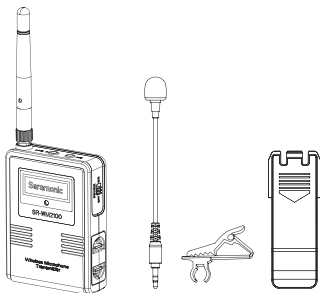

### TX

- Body pack transmitters: TX×2
- Omni-directional lavalier microphones×2
- Microphone clips×2
- Antennas×2
- Belt clips×2
- Windscreens×2

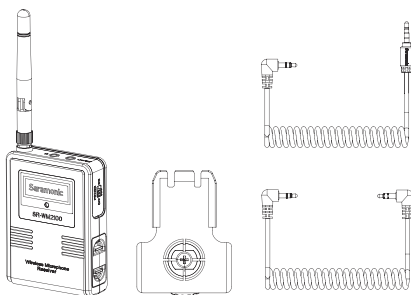

## RX9

- Portable receiver: RX9 × 1
- 3.5mm TRS audio output cable × 1
- 3.5mm TRS to TRRS (CTIA standard) audio output cable × 1
- Shoe mount adapter × 1
- Antenna × 1
- Pairing pin × 1



Scan the QR code and follow us!  
扫描微信关注枫笛公众号

---

**Shenzhen Jiayz Photo Industrial., Ltd**  
深圳市长丰影像器材有限公司

A16 Building, Intelligent Terminal Industrial Park of Silicon Valley  
Power, Guanlan, Longhua District, Shenzhen, China  
深圳市龙华区观澜街道大富工业区硅谷动力智能终端产业园 A16 栋

☎ 400-613-1096

🌐 [www.saramonic.com](http://www.saramonic.com)

✉ [info@saramonic.com](mailto:info@saramonic.com)