

# ChildLife<sup>®</sup>

## Playsets

PG203

(MONKEY BARS)

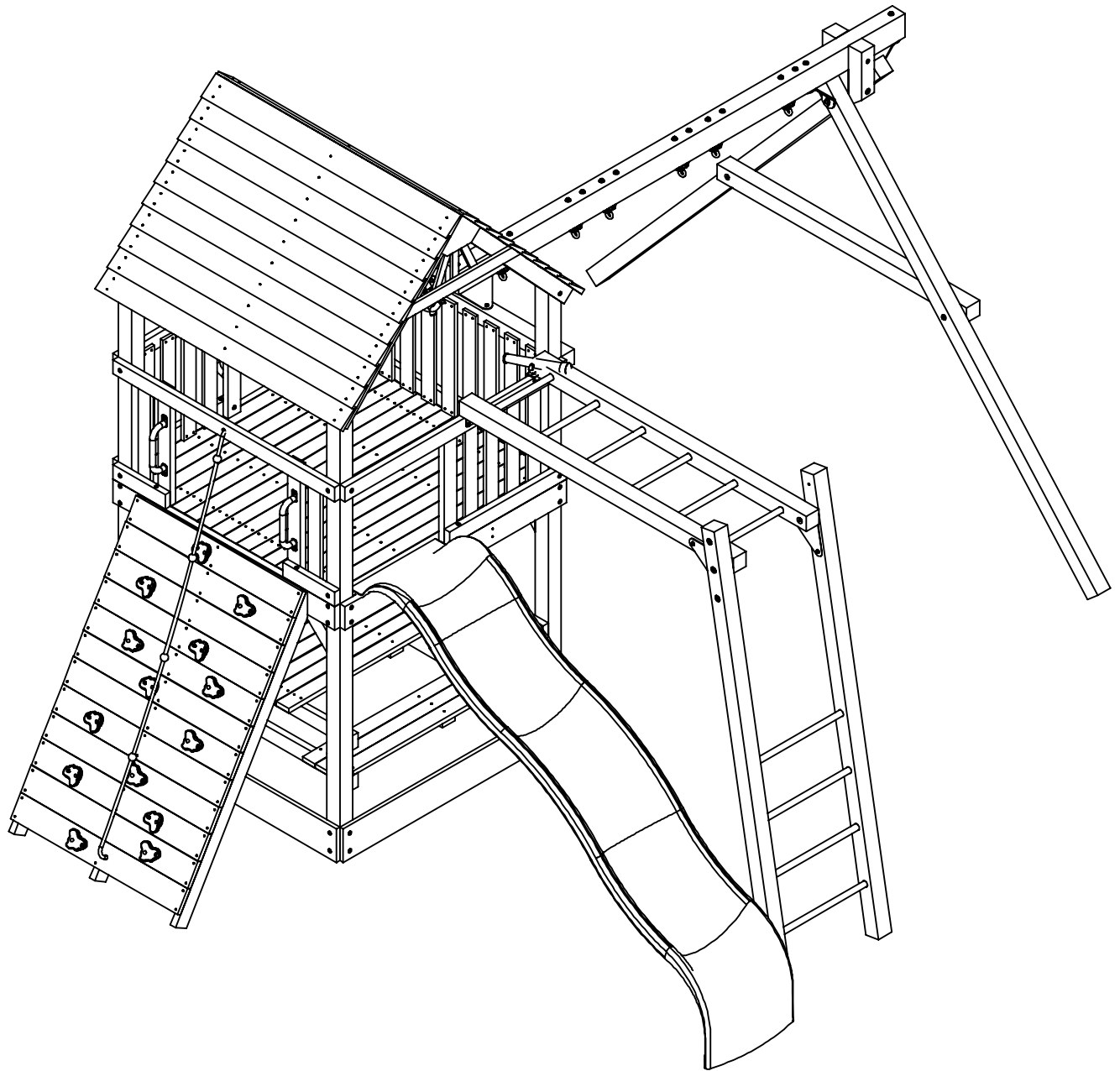

PA-MA-0006-04

# PARTS LIST

ITEM NO.	PART NUMBER	DESCRIPTION	QTY.
1	PG-HW-M005	MONKEY BAR BRACKET	2
2	PG-HW-M006	MONKEY BAR TRIANGLE PLATE	2
3	PG-ST-0002	19" ROUND RUNG	6
4	PG-44-0012	HORIZONTAL LADDER RAIL - RIGHT	1
5	PG-44-0011	HORIZONTAL LADDER RAIL - LEFT	1
6	PG-ST-0001	25 3/4" ROUND RUNG	4
7	PG-44-0009	VERTICAL LADDER RAIL - LEFT	1
8	PG-44-0010	VERTICAL LADDER RAIL - RIGHT	1
9	PG-HW-S006	#10 X 2" SELF TAPPING SCREW	20
10	PG-HW-W002	1/4" FLAT WASHER	8
11	PG-HW-L001	1/4" x 1.5" LAG SCREW	8
12	PG-HW-W003	5/16" FLAT WASHER	4
13	PG-HW-L003	5/16" X 2.5" LAG SCREW	4
14	PG-HW-W004	3/8" FLAT WASHER	4
15	PG-HW-B001	3/8"-16 x 6.5" HEX BOLT	2
16	PG-HW-N001	3/8" NYLON LOCKNUT	2
17	PG-HW-N003	3/8"-16 ACORN NUT	2

# STANDARD PARTS

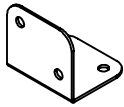

#1  
MONKEY BAR BRACKET  
PG-HW-M005  
(2)

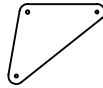

#2  
MONKEY BAR TRIANGLE PLATE  
PG-HW-M006  
(2)

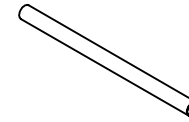

#3  
19" ROUND RUNG  
PG-ST-0002  
(6)

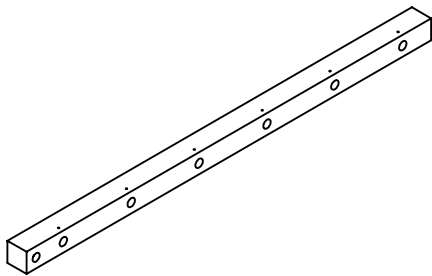

#4  
HORIZONTAL LADDER RAIL - RIGHT  
PG-44-0012  
(1)

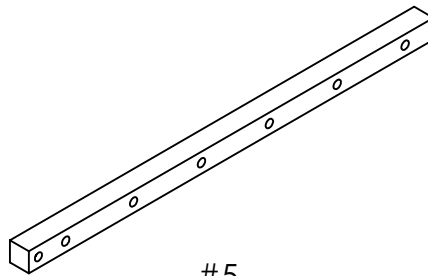

#5  
HORIZONTAL LADDER RAIL - LEFT  
PG-44-0011  
(1)

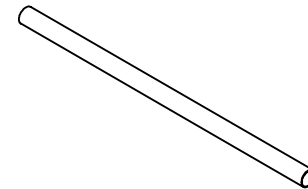

#6  
25 3/4" ROUND RUNG  
PG-ST-0001  
(4)

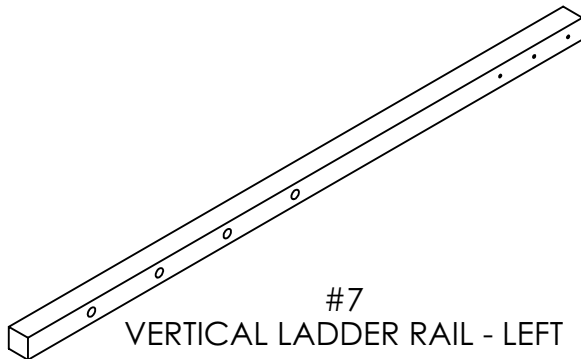

#7  
VERTICAL LADDER RAIL - LEFT  
PG-44-0009  
(1)

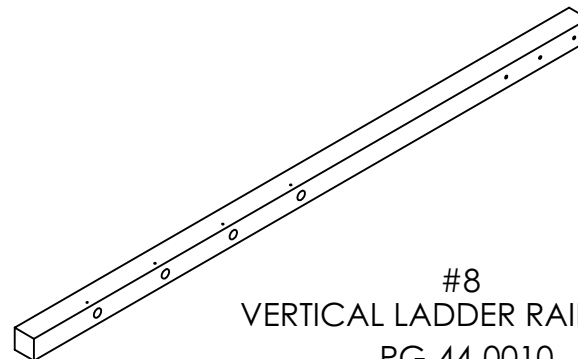

#8  
VERTICAL LADDER RAIL - RIGHT  
PG-44-0010  
(1)

# HARDWARE

**NOTE TO INSTALLER**  
 You must assemble this product in accordance with these Assembly Instructions.  
 After assembly is complete, please give this Owner's Manual to the owner of the play system.

**Measurement taken from bottom of bolt head to the bottom of bolt**

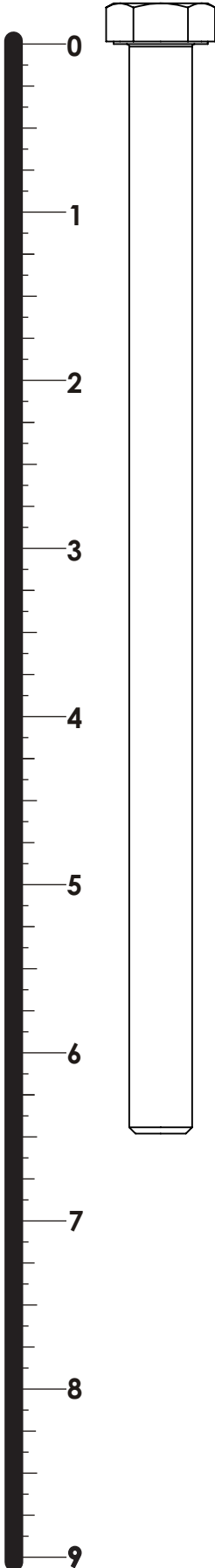

**#15**  
**3/8-16" X 6.5" HEX BOLT**  
**PG-HW-B001**  
**(2)**

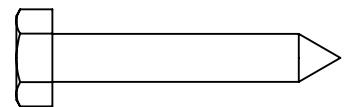

**#11**  
**1/4" X 1.5" Lag Screw**  
**PG-HW-L001**  
**(8)**

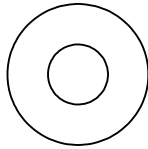

**#10**  
**1/4" Flat Washer**  
**PG-HW-W002**  
**(8)**

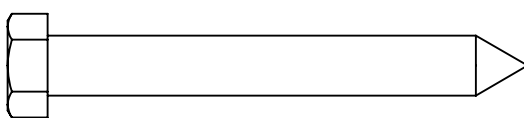

**#13**  
**5/16" x 2.5" Lag Screw**  
**PG-HW-L003**  
**(4)**

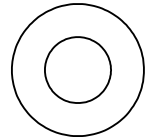

**#12**  
**5/16" Flat Washer**  
**PG-HW-W003**  
**(4)**

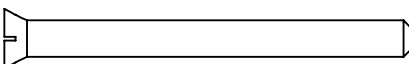

**#9**  
**#10 X 2" Self Tapping Screw**  
**PG-HW-S006**  
**(20)**

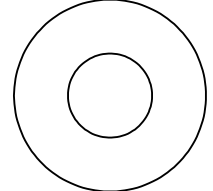

**#14**  
**3/8" Flat Washer**  
**PG-HW-W004**  
**(4)**

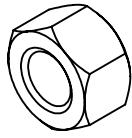

**#16**  
**3/8" NYLON LOCK NUT**  
**PG-HW-N001**  
**(2)**

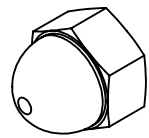

**#17**  
**3/8"-16 ACORN NUT**  
**PG-HW-N003**  
**(2)**

## VERTICAL LADDER RAILS ASSEMBLY

### PARTS NEEDED

#6	25 3/4" ROUND RUNG	(4)
#7	VERTICAL LADDER RAIL - LEFT	
(1)		
#8	VERTICAL LADDER RAIL - RIGHT	(1)

1. On a flat surface lay item #8 with holes facing up, insert items #6 into holes.
2. Lining up holes with items #6 place item #7 onto items #6.
3. Once all items are in place secure by tapping item #7 lightly with rubber mallet ensuring items #6 are firmly seated in items #7 and #8.

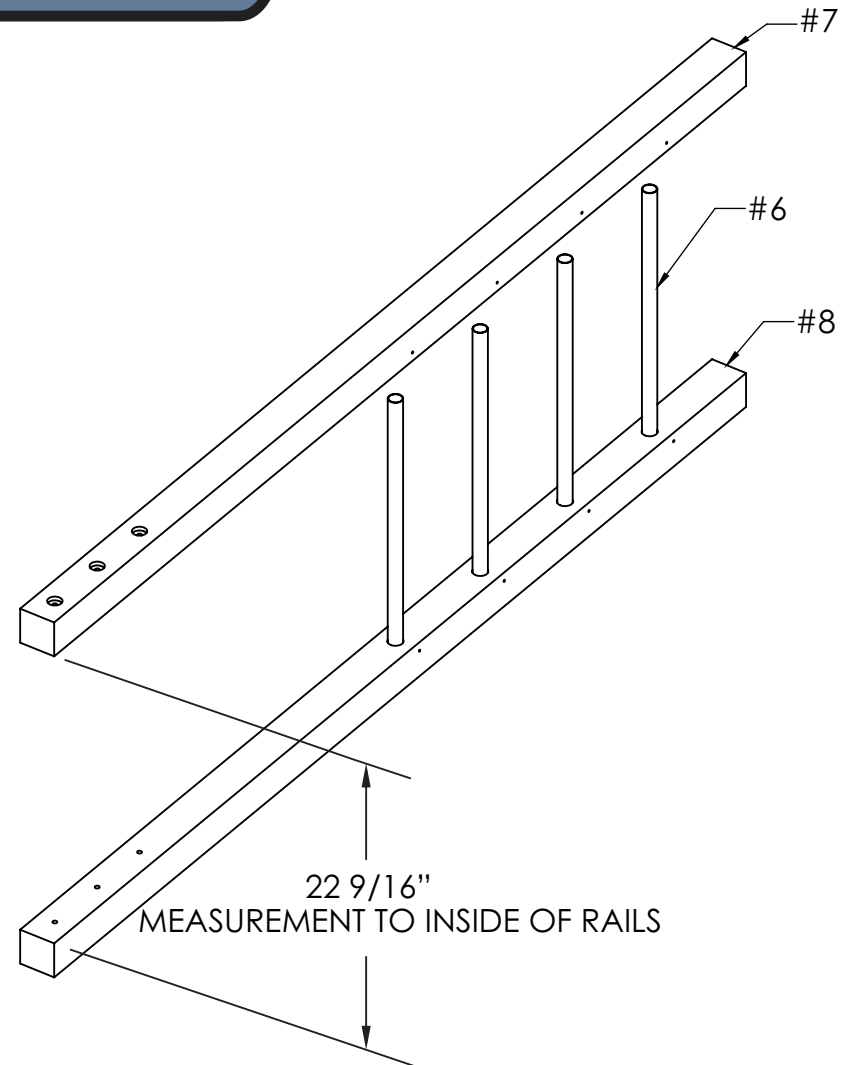

**NOTE:** After assembly width at both ends should be 22 9/16" inside to inside.

## VERTICAL LADDER RUNG TO LADDER RAILS ATTACHMENT

### HARDWARE NEEDED

#9 #10 X 2" SELF TAPPING SCREWS (8)

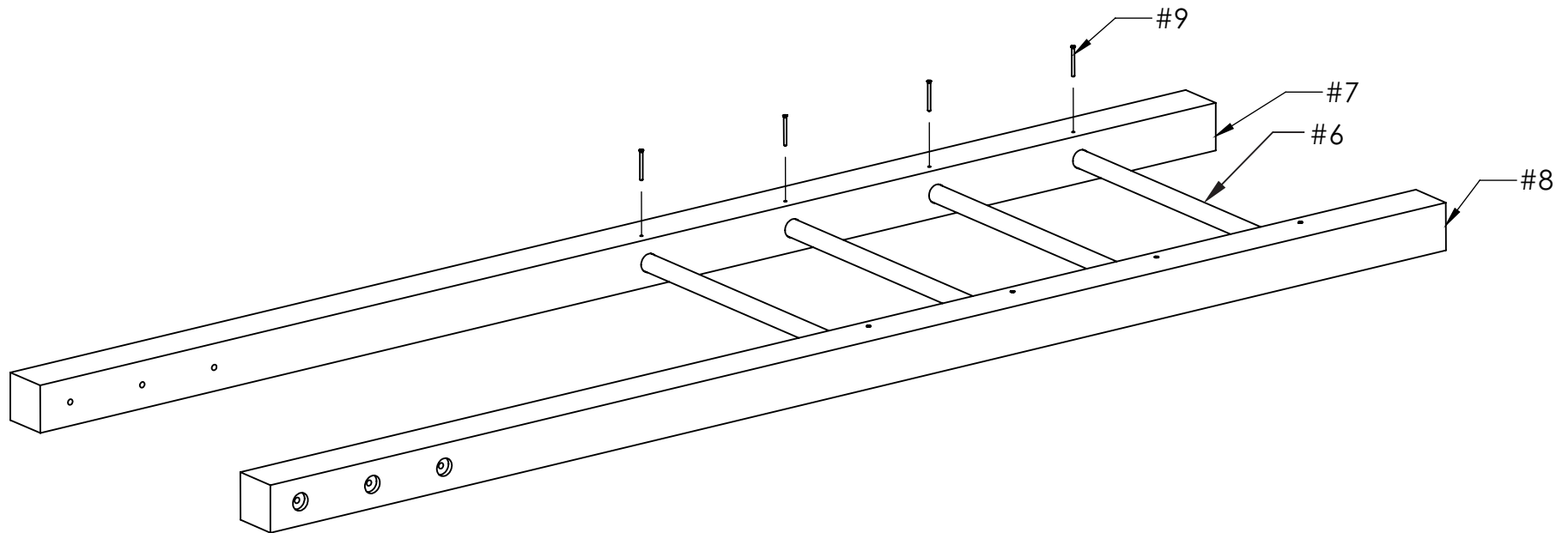

1. Lay Vertical Ladder Assembly with screw holes facing up, and secure items #6 to items #7 and #8 with hardware item #9

## HORIZONTAL LADDER RAILS ASSEMBLY

1. On a flat surface lay item #5 with holes facing up, insert items #3 into holes.
2. Lining up holes with items #3 place item #4 onto items #3.
3. Once all items are in place secure by tapping item #4 lightly with rubber mallet ensuring items #3 are firmly seated in items #4 and #5.

### PARTS NEEDED

#3	19" ROUND RUNG	(6)
#4	HORIZONTAL LADDER RAIL - RIGHT	(1)
#5	HORIZONTAL LADDER RAIL - LEFT	(1)

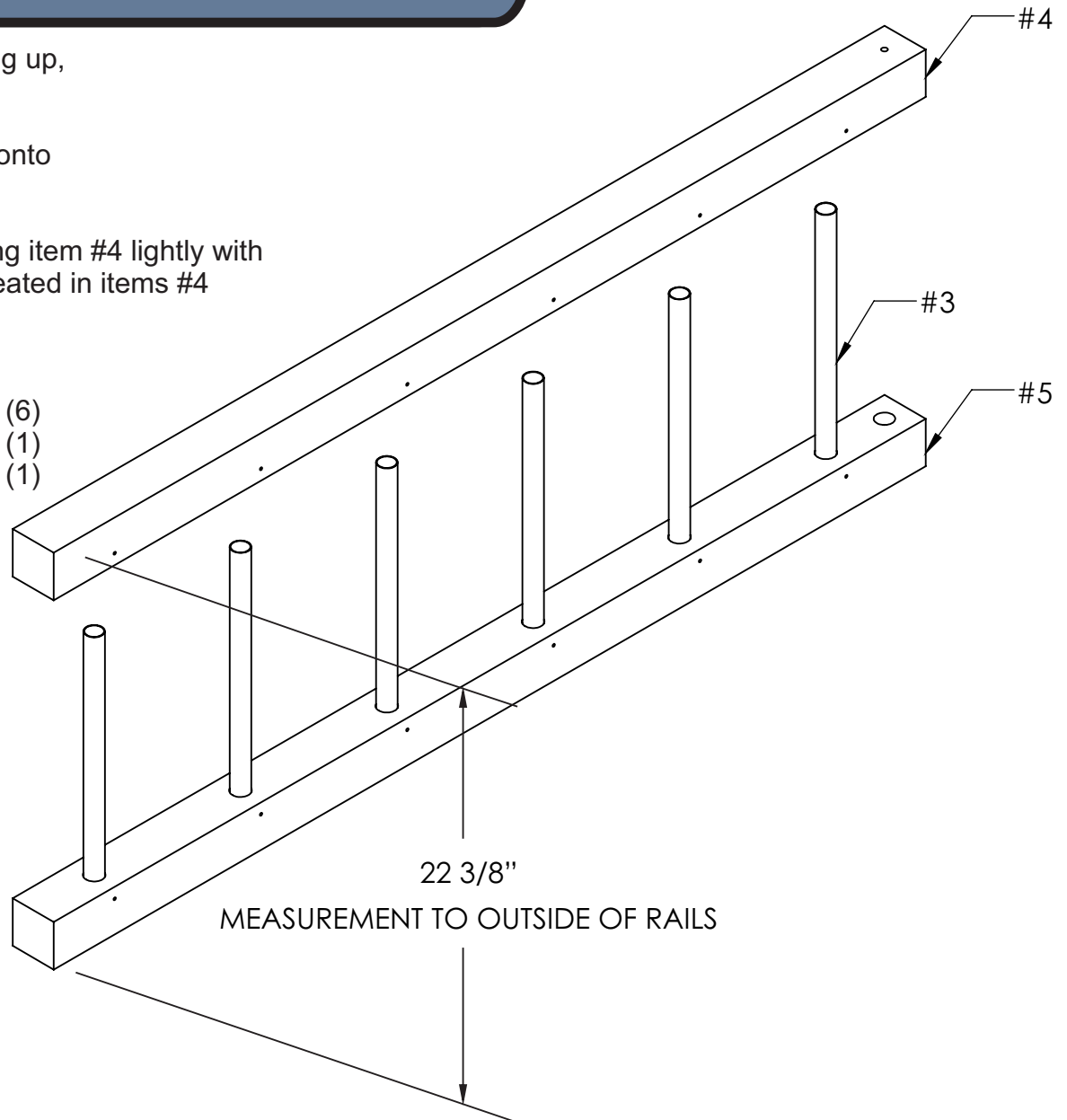

**NOTE:** After assembly width at both ends should be 22 3/8" outside to outside.

## HORIZONTAL LADDER RUNG TO LADDER RAILS ATTACHMENT

### PARTS NEEDED

#1 MONKEY BAR BRACKET (2)

### HARDWARE NEEDED

#9 #10 X 2" SELF TAPPING SCREWS (12)

#10 1/4" WASHER FLAT (4)

#11 1/4" X 1.5" LAG SCREW (4)

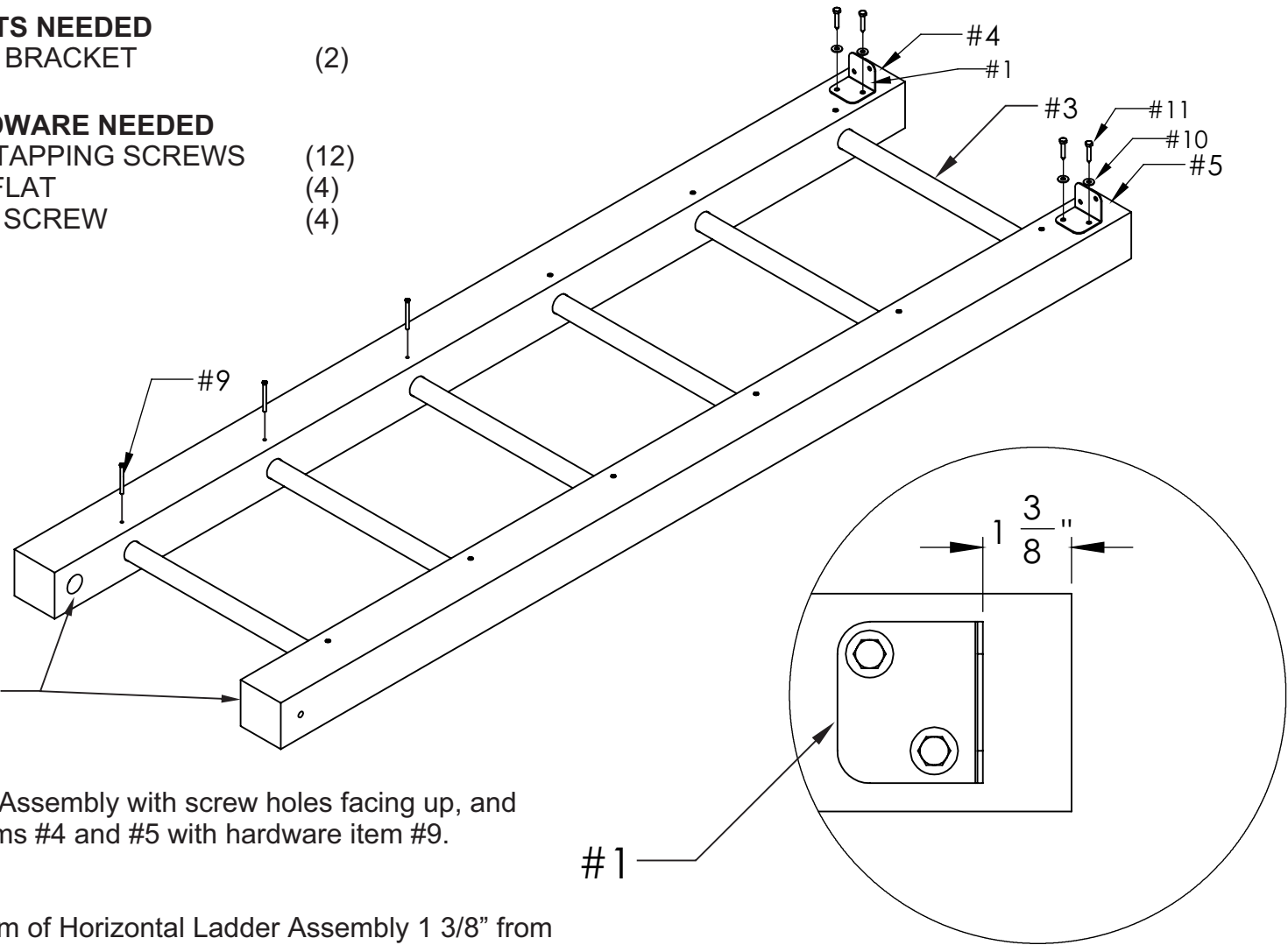

NOTE: Install #1 Brackets on the opposite end of the countersinks.

1. Lay Horizontal Ladder Assembly with screw holes facing up, and secure items #3 to items #4 and #5 with hardware item #9.

2. Attach item #1 to bottom of Horizontal Ladder Assembly 1 3/8" from end of rail using hardware items ##10 and #11.

**(Bracket to be centered on Ladder Rail)**

BRACKET TO BE CENTERED ON LADDER RAIL



**NOTE: Three holes are provided in the Vertical Ladder to allow for adjustment of grade of yard. Use center hole for level ground.**

1. Attach item #2 to Horizontal Ladder Assembly using pre-drilled hole and hardware item #12 and #13.  
**(Edge of item #2 should align with edge of Horizontal Ladder Assembly)**
2. Attach Vertical Ladder Assembly to Horizontal Ladder Assembly and item #2 using hardware items #14, #15, #16, and #17.
3. Attach item #2 to Vertical Ladder Assembly using hardware item #12 and #13.

**PARTS NEEDED**

	VERTICAL LADDER ASSEMBLY	(1)
	HORIZONTAL LADDER ASSEMBLY	(1)
#2	MONKEY BAR TRIANGLE PLATE	(2)

**HARDWARE NEEDED**

#12	5/16" FLAT WASHER	(4)
#13	5/16" X 2.5" LAG SCREW	(4)
#14	3/8" FLAT WASHER	(4)
#15	3/8"-16 X 6.5" HEX BOLT	(2)
#16	3/8" NYLON LOCK NUT	(2)
#17	3/8"-16 ACORN NUT	(2)

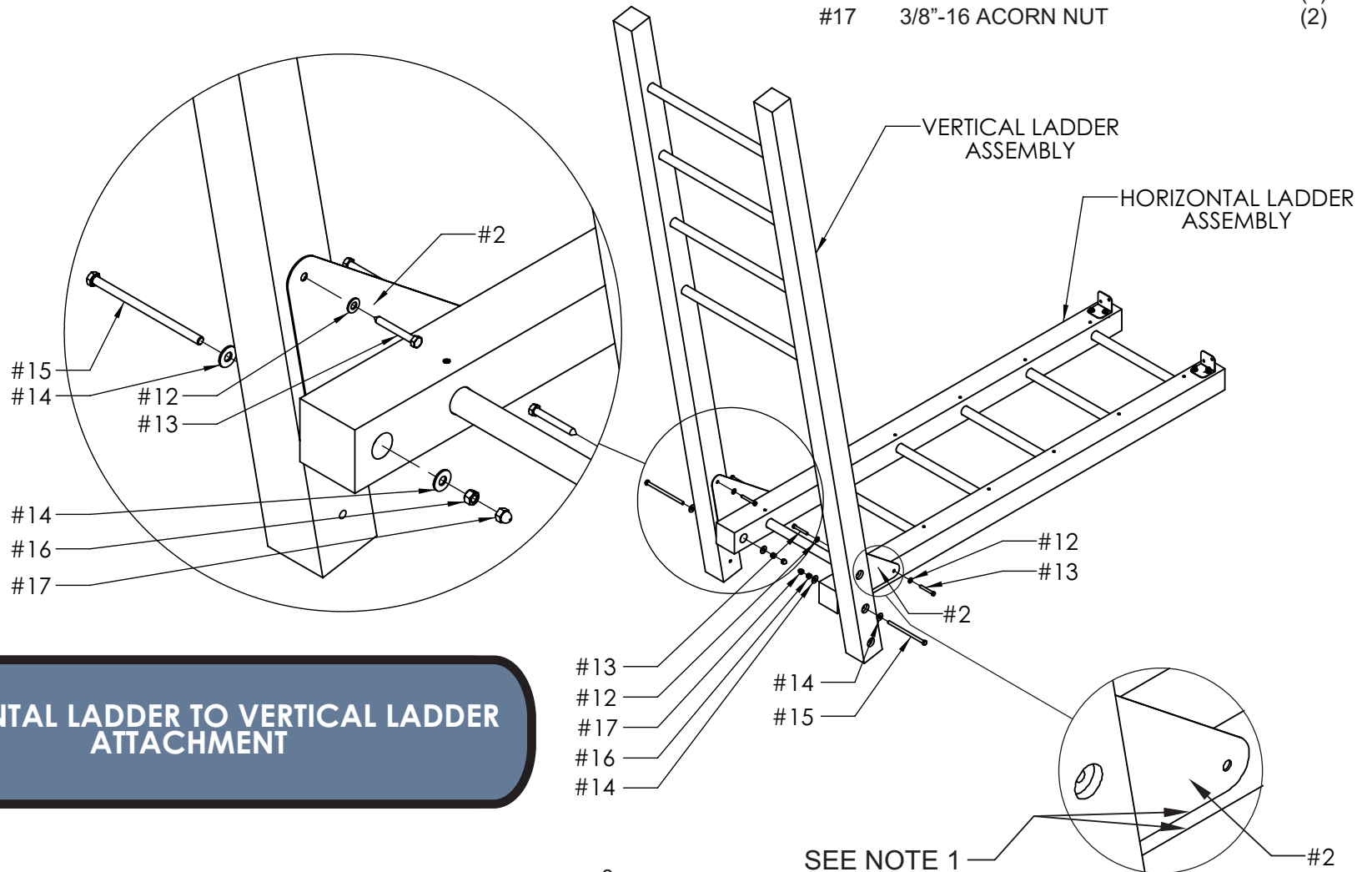

**HORIZONTAL LADDER TO VERTICAL LADDER ATTACHMENT**

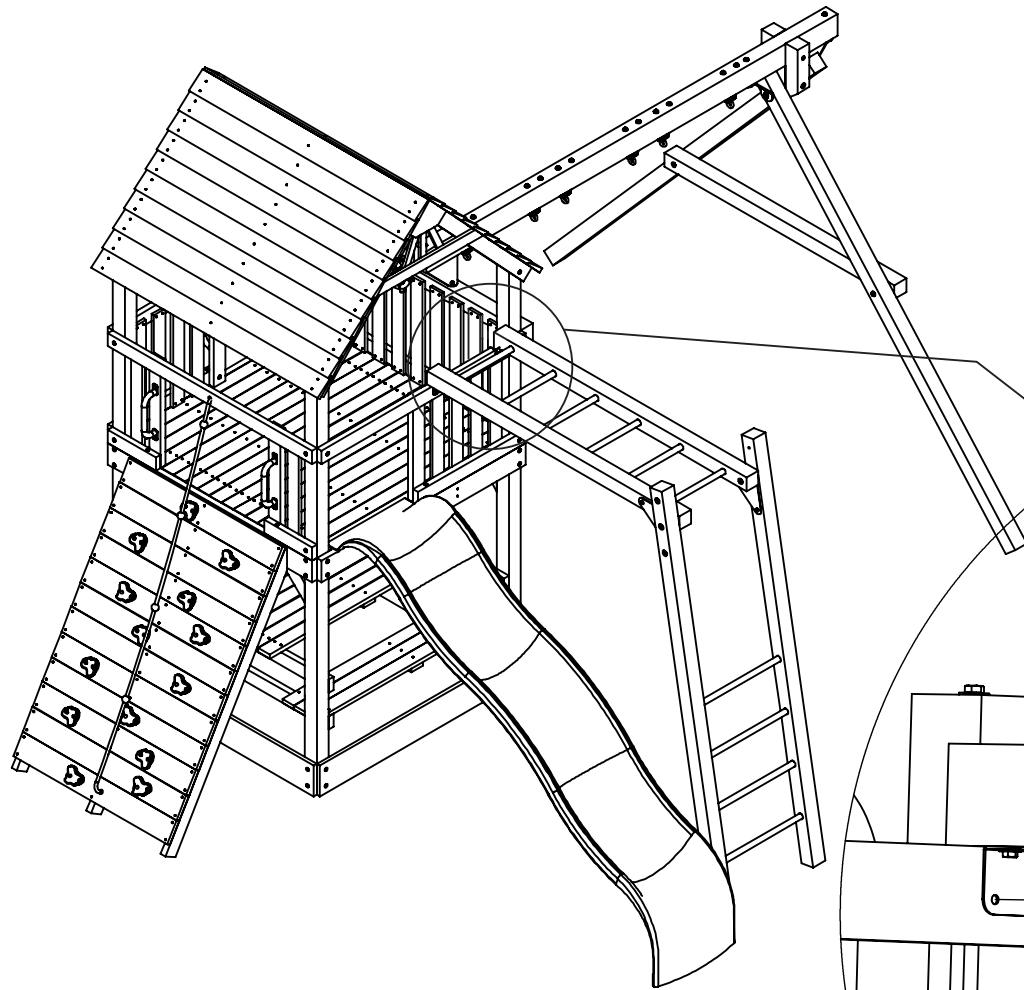

<b>PARTS NEEDED</b>		
PLAY SET ASSEMBLY		(1)
MONKEY BAR ASSEMBLY	(1)	

<b>HARDWARE NEEDED</b>		
#10	1/4" WASHER FLAT	(4)
#11	1/4" X 1.5" LAG SCREW	(4)

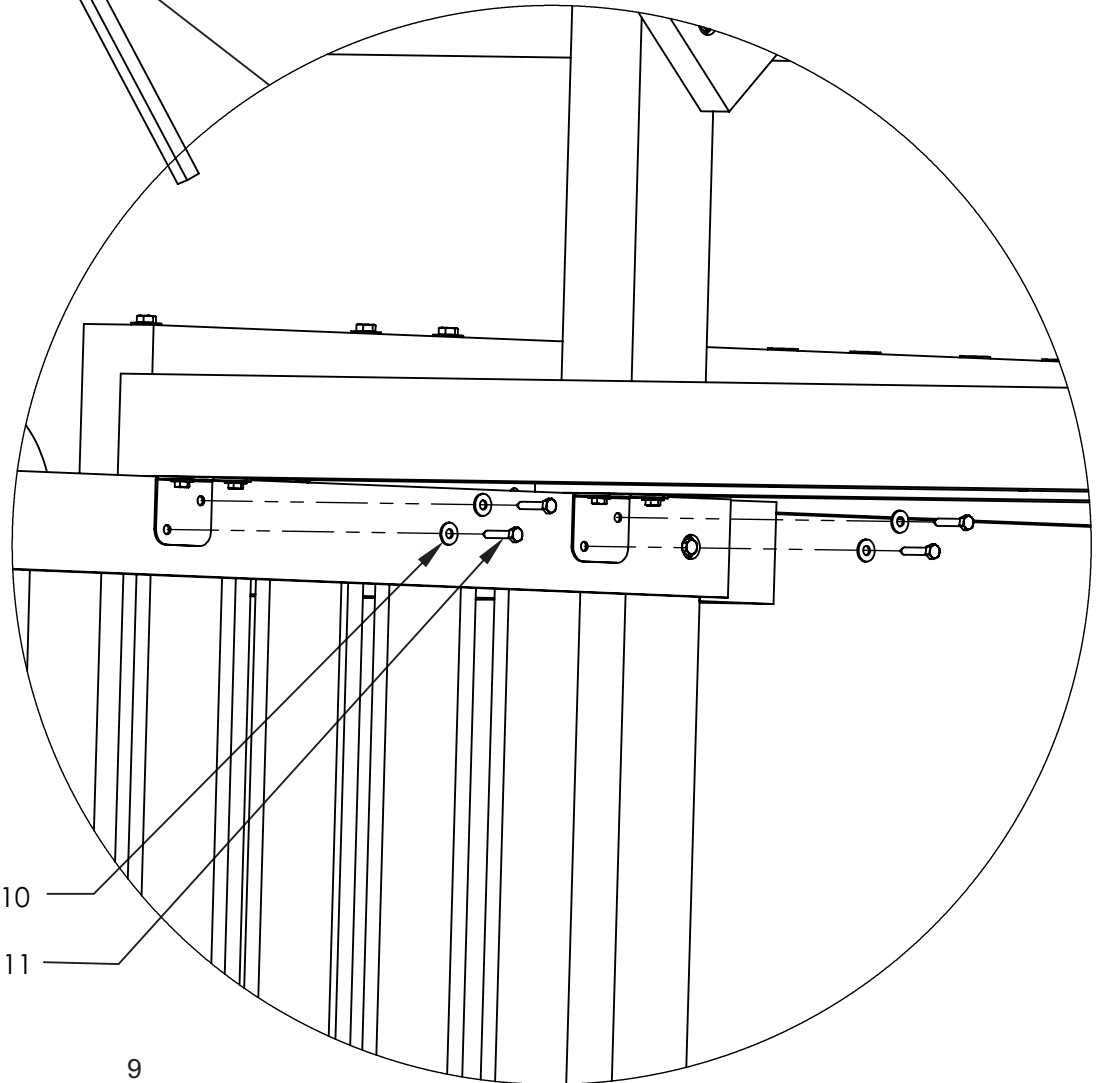

#10

#11

1. Center and place Monkey Bar Assembly against Play set Assembly as shown.
2. Attach using hardware items #10 and #11 as shown.

# ChildLife® Playsets

ChildLife Limited Lifetime  
& TwoYear Warranties

Subject to proper installation and normal residential use, Escalade Sports warrants, subject to the limitations stated below, to the original retail purchaser, all chain, seats, swing hangers, hardware, metal braces, ropes and accessories to be free from defects in material and workmanship for a period of two years from date of purchase. Cracks in non-functional plastic components are not considered defects in materials and workmanship if they do not affect the functionality of the playset. Merchandise covered under this limited two-year warranty will, at our option, be repaired or replaced, excluding **any freight or labor fees that may be required.**

In addition, for the lifetime of the playset, Escalade Sports warrants, to the original retail purchaser, all wooden components against structural failure due to corrosion, wood rot, or insect infestation. **Seasonal checks and surface cracks, knotholes and knots, natural characteristics of all wooden play equipment, not resulting in structural failure, are not covered under this warranty.**

Timber is a natural material which can absorb and release moisture. Although this product is designed to minimize this effect, in certain circumstances some movement or distortion is unavoidable. During dry hot weather timber may shrink and check - this is a normal process of weathering. After the first year of service it is advisable to apply a non-toxic stain / sealant safe for children's use.

Components covered under this limited lifetime warranty will be replaced free of charge excluding freight and labor fees.

**Non-residential use of the playset is prohibited and voids the warranty as the playsets are designed for residential use only.**

Escalade Sports reserves the right to examine photographs and/or physical evidence of merchandise claimed to be defective, and to recover said merchandise, prior to disposition of warranty claims. Merchandise returned to our factory for examination or recovery must be shipped freight prepaid, unless a Return Authorization Number is issued.

No warranty is offered on equipment subjected to abuse, negligence, improper installation, vandalism, acts of God, unauthorized alteration or attachment to equipment other than our own, or improper use, service or repair by customer or any third party. Escalade Sports assumes no responsibility for incidental or consequential damages which may arise from the purchase or use of our equipment. Please supervise your children's play activity and maintain your play equipment periodically.

THIS WARRANTY IS EXPRESSLY IN LIEU OF ALL OTHER WARRANTIES, EXPRESSED OR IMPLIED, INCLUDING WARRANTIES OF MERCHANTABILITY OR FITNESS FOR USE. CHIDLIFE PLAYSETS DOES NOT ASSUME, OR AUTHORIZE ANY PERSON TO ASSUME FOR US, ANY OTHER LIABILITY IN CONNECTION WITH THE SALE OF OUR PRODUCTS.

**For warranty service, contact:**

Childlife Playsets  
Escalade Sports  
P.O. Box 889  
Evansville, IN 47706  
1-800-GO-SWING

Or E-Mail us at: [playgroundcs@escaladesports.com](mailto:playgroundcs@escaladesports.com)

Revised 2014