

FLEXSTEEL®

W1013-8341/8342

Round Dining Table

IMPORTANT NOTES

Carefully remove all the parts from the carton and put them individually on a soft cloth to prevent damage to the parts.

We have taken great care in the design of this product and request that you carefully and accurately follow our assembly instructions to ensure proper set-up.

We recommend at least two adults assemble this product.

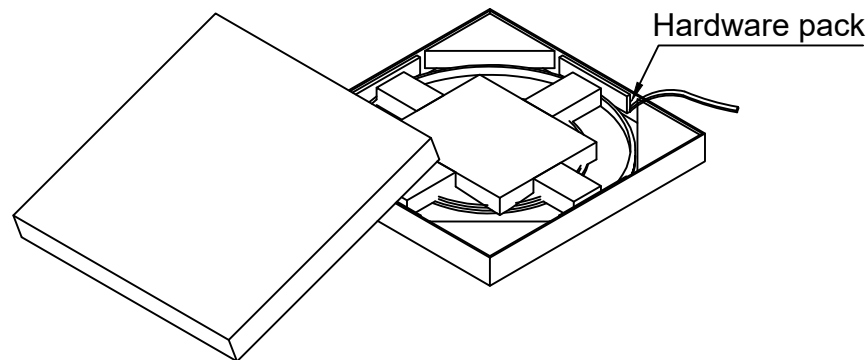
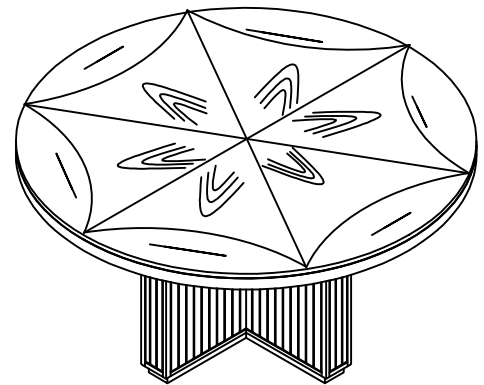

Part List

Assembly Instruction 1/4

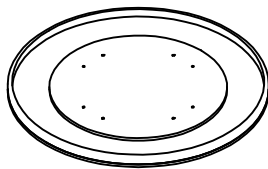

A. Table Top
1 piece



B. Assembly Panel
1 piece

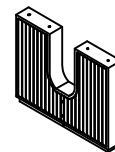

C. U shape Leg
1 piece



D. L shape Leg
2 pieces

Hardware List

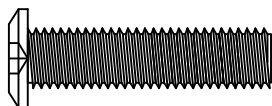

E. Small Bolt
Ø5/16" - 18 UNC x 1"
8 pieces

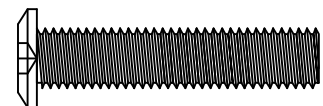

F. Large Bolt
Ø5/16" - 18 UNC x 1-3/8"
10 pieces



G. Spring Washer
Ø5/16" x 1.5mm
18 pieces



H. Flat Washer
Ø5/16 x Ø16mm x 2mm
18 pieces

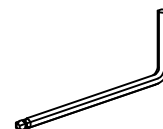

I. Hex Key 4mm
1 piece

IMPORTANT NOTES

- Do not tighten up all the screws until each part is properly assembled.
- Keep the Hex Key in a safe place as you may need to tighten up the bolts in the future.
- Use a soft cloth between these parts and the floor.
- We recommend this product be assembled by at least two adults.

STEP 1

Attach two the L shape Legs (D) to the U shape leg, Attach all Large Bolts (F), Spring Washer (G), and Flat Washer (H), level L shape Legs to U shape leg then tighten with the Hex Key (I). (See Figure 1).

Figure 1

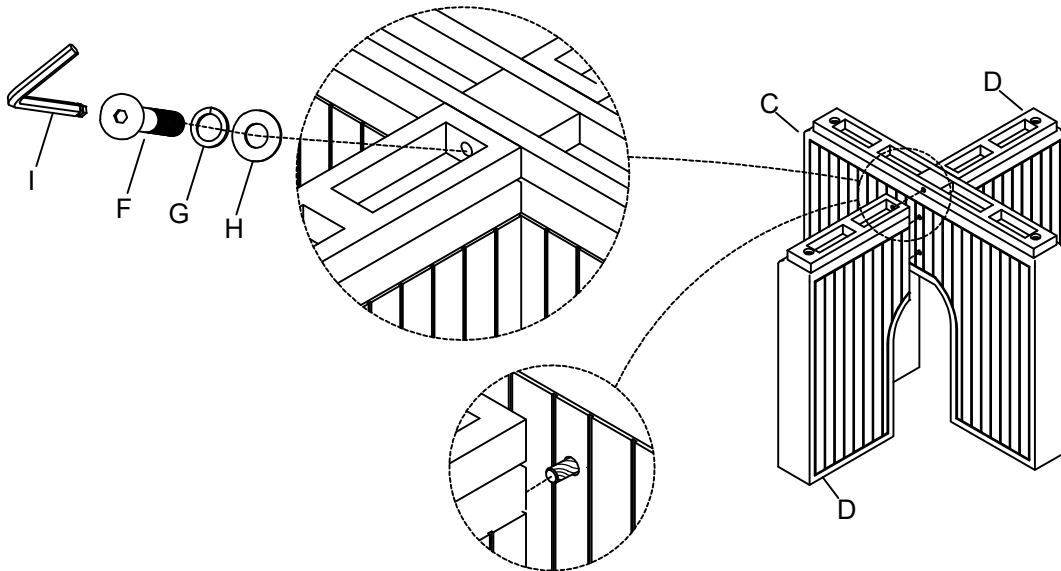

STEP 2

Attach the Assembly Panel (B) to the U shape Leg (C) and the L shape Leg (D), Attach all Large Bolts (F), Spring Washer (G), and Flat Washer (H), level Assembly Panel to U shape Leg and L shape Leg then tighten with the Hex Key (I). (See Figure 2).

Figure 2

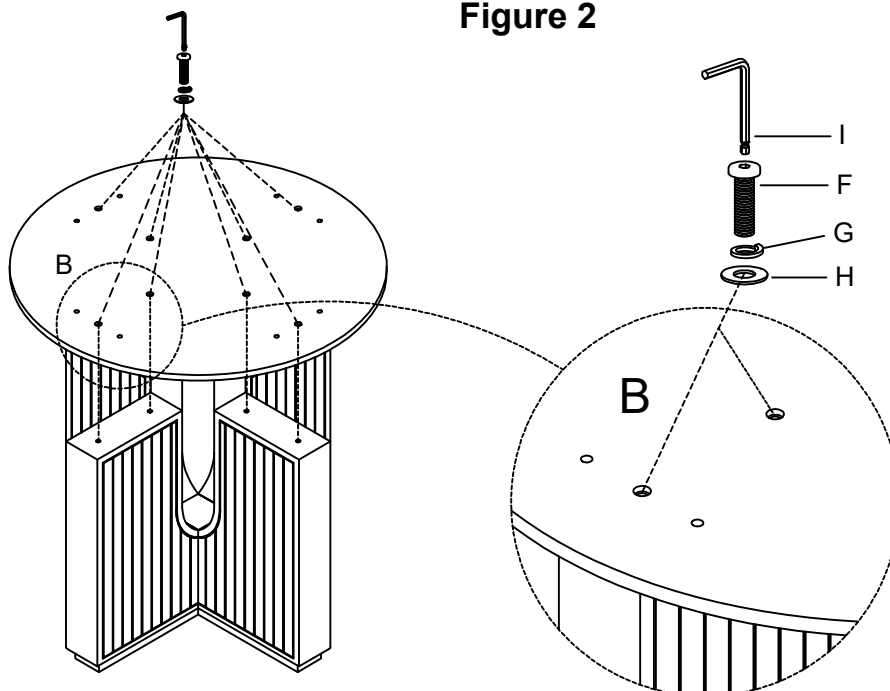

STEP 3

Carefully place the Table Top (A) upside down on a soft surface. Fix the Table Top (A) to the assembled table base using Attach all Small Bolts (E), Spring Washer (G), and Flat Washer (H), level two legs to Table Top then tighten with the Hex Key (I). (See Figure 3).

Figure 3

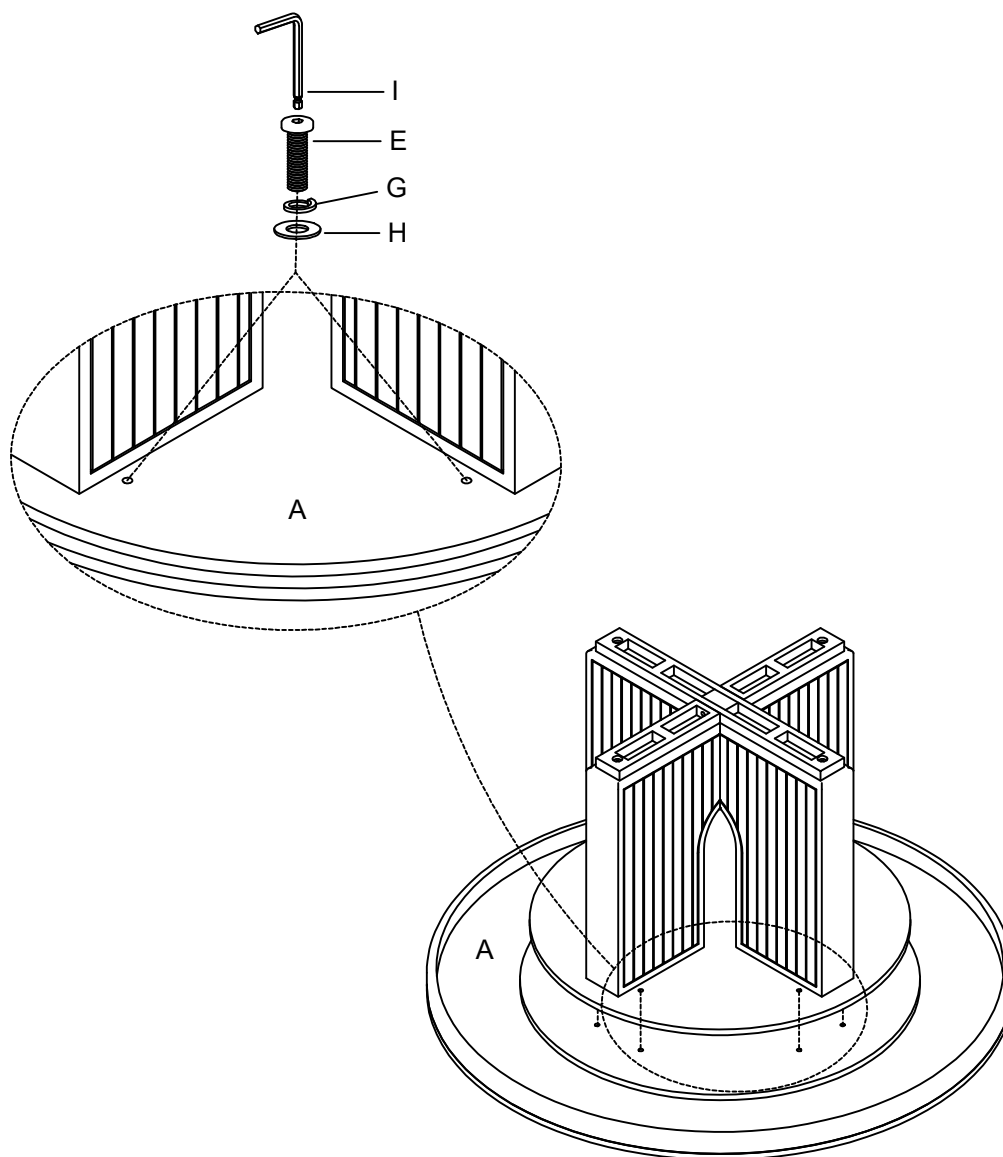

STEP 4

Ask for assistance to lift the unit upright and position it at the desired location.
Adjust the levelers on the legs until the furniture is leveled. (See Figure 4).

Figure 4

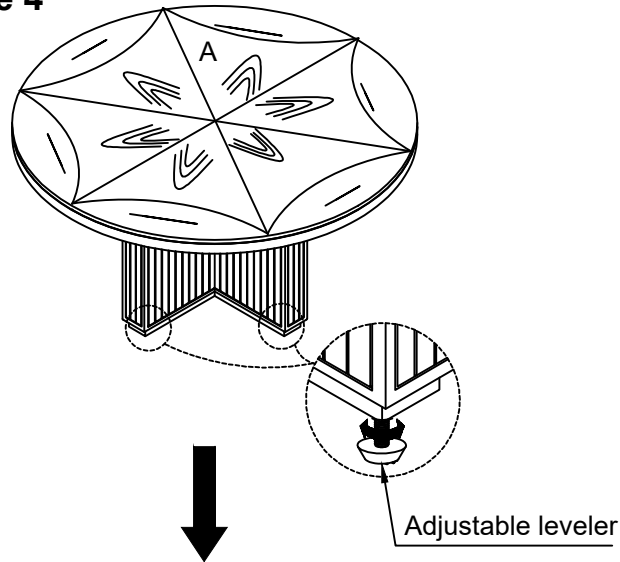

STEP 5

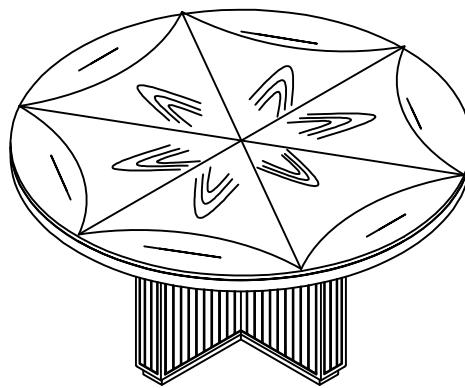

CARE INSTRUCTIONS

- To avoid scratches, do not place sharp or jagged objects directly on the table top.
- Do not place hot items directly on the table top.
- Use placemats or trivets under hot items and coasters under beverages to prevent marks and stains.
- Avoid the use of harsh chemicals or abrasive cleaning materials.
- Wipe the table clean with a soft, dry cloth after each use.
- Wipe up spills quickly with a soft, dry cloth.

Flexsteel Industries, Inc.

For Parts or Customer Service call
toll-free:

1-888-415-3979

Monday-Friday

8:00 a.m. -5:00 p.m.

(Central Time)

Email:

customersolutions@flexsteel.com

www.flexsteel.com