

Safely and stylishly display
convenience foods with Admiral Craft's
HFD-85 • 85 Liter (3 Cu. Ft)
HOT FOOD DISPLAY

Safely and stylishly display hot wrapped foods such as pizzas, burgers and more with this 85 Liter Hot Food Display. This merchandiser utilizes 1160 watts of heating power to keep food at a safe, ready-to-serve temperature so your customers can quickly and conveniently grab something to eat. Independent heat and light controls on each shelf allow for specific display and holding conditions for different foods, giving increased marketing potential.

Built for durability, this merchandiser utilizes a stainless steel frame with tempered glass sides for maximum visibility. It also includes adjustable divider rods to quickly and easily separate your most popular foods for display.

- Stainless steel exterior
- Tempered glass sides
- Independent heat and light controls for each shelf
- Adjustable thermostat
- Adjustable divider rods for easy organization of food product
- Fixed rubber feet
- CE Certified



Call for more info:
1-800-223-7750



Admiral Craft
Equipment Corp.

800 Shames Drive, Westbury, NY 11590
PHONE 516-433-3535 | FAX 516-433-4453

admiralcraft.com

HFD-85 • 85 Liter

HOT FOOD DISPLAY

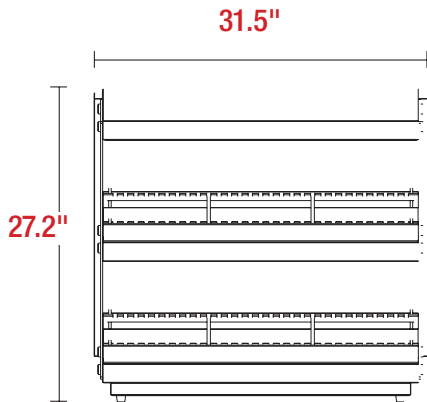

Front View

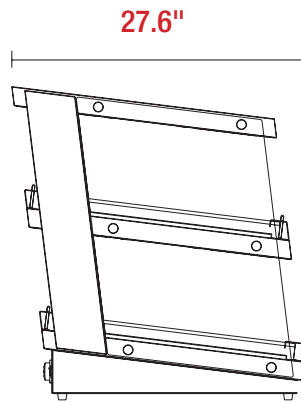

Side View

MODEL NUMBER	HFD-85
Rated Input Power	1160W
Temperature Range	86°– 194°F
Capacity	85 Liters
Overall Dimensions (in)	31.5"L x 27.6"W x 27.2"H
Display Area	3 Cu. Ft.
Voltage/Hertz/Phase	120/60/1
Amps	10
Net Weight (lbs)	90.5 lbs
Gross Weight (lbs)	97 lbs
Shipping Dimensions (in)	34"L x 30.2"W x 29"H

For more information about this or any of our other products, go to admiralcraft.com. This item is listed on AutoQuotes. For full explanation of warranty coverage on this product, please refer to warranty page located in the owner's manual and warranty section at admiralcraft.com. Specifications subject to change without notice. Please confirm at time of order.

