

# Hanging Slim Pedestal Assembly Instructions





## Tools Required for Assembly

- Phillips screwdriver or bit
- Power drill
- Tape measure
- 1/8" Drill depth collar
- 1/8" drill bit

## Important

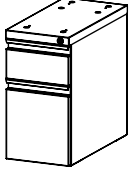
Read all instructions, review illustrations and identify all parts prior to assembly.

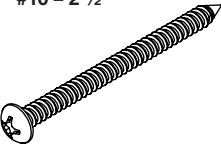
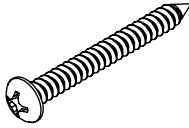
## Included Components

<p><b>1. Hanging Pedestal</b></p>  <p>x 1</p>	<p><b>2. Standoff – 1" and 2"</b></p>  <p>x 4</p>	<p><b>3. Extra Long Screw #10 – 2 1/2"</b></p>  <p>(Use with 2" standoffs) x 4</p>	<p><b>4. Long Screw #10 – 1 3/4"</b></p>  <p>(Use with 1" standoffs) x 4</p>	<p><b>5. Flush Mount Screw #10 – 3/4"</b></p>  <p>(For flush mounting) x 4</p>	<p><b>6. Cup Washer</b></p>  <p>x 4</p>
--	--	---	--	---	--

## Assembly Instructions

1. Remove all drawers from the hanging pedestal by lifting slide tab on the left and lowering the slide tab on the right simultaneously. **[FIGURE 1]**
2. Flip desk upside down on non-marking surface such as carpet or foam pads.
3. Set the pedestal on the cross beams and locate the front of the hanging pedestal in the desired location and verify that at least two of the rear mounting holes are clear of any cross braces. The front of the pedestal may need to be set back from the front of the desk. If mounting on height adjustable desk, mount on opposite side of lift controls. **[FIGURE 2]**

Use the provided template to make marks on the front 2 mounting holes.

- a. Mark the 4 flush mount holes if using a desk without cross braces.

4. Set up the depth collar on the 1/8" drill bit to drill a 1/2" deep hole. Depth collar will prohibit drilling too deeply and damaging work surface. In absence of depth collar, tape can be used on the drill bit to mark 1/2".

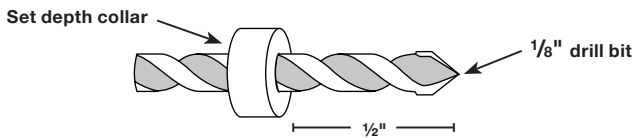

5. Drill the front 2 holes to 1/2" deep at the marks made in **Step 3**.

**! WARNING** - Drilling too deeply will damage work surface.

6. Using a screw, cup washer and a standoff, screw the hanging pedestal into one of the pre-drilled holes in the work surface from **Step 5**. **[FIGURE 3]**

**! WARNING** - Using wrong screw size will damage work surface.

- a. Use short flush mount screws and do not use a stand-off if flush mounting to a desk without cross bracing.
- b. Use the long screws and the 1" spacer to mount to desks with up to 1" tall cross braces. (Hirsch desk)
- c. Use the extra-long screws and 2" spacer to mount to desks with cross braces between 1-2" tall. (most height adjustable desks)

7. Repeat process for remaining three standoffs.

8. Flip work surface right-side up.

9. Re-install drawers into the hanging pedestal.

**FIGURE 1**

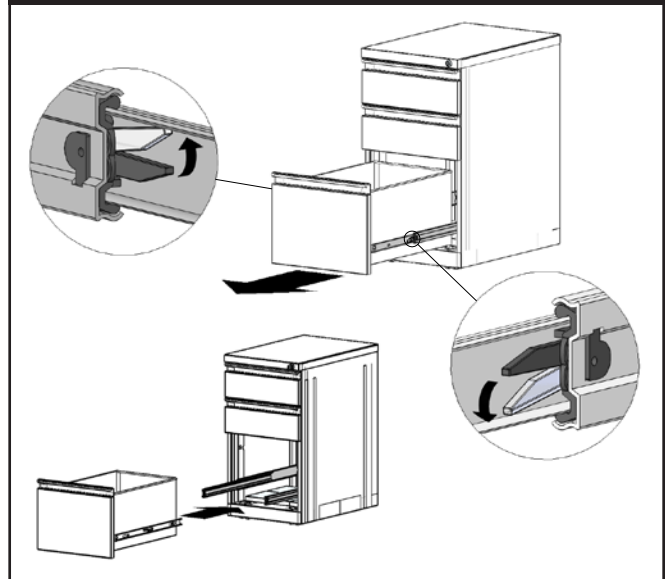

**FIGURE 2**

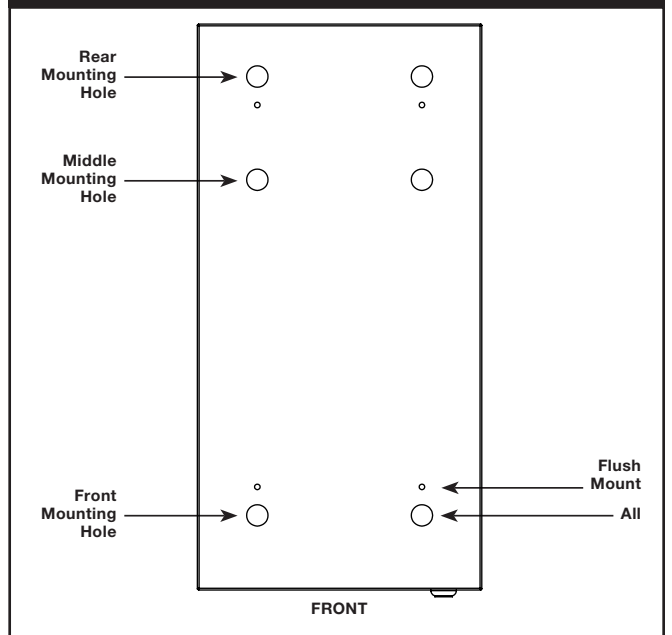

# Hanging Slim Pedestal Assembly Instructions

**FIGURE 3**

- Long Screw
- Cup Washer
- Standoff
- Pre-Drilled Holes
- Work surface

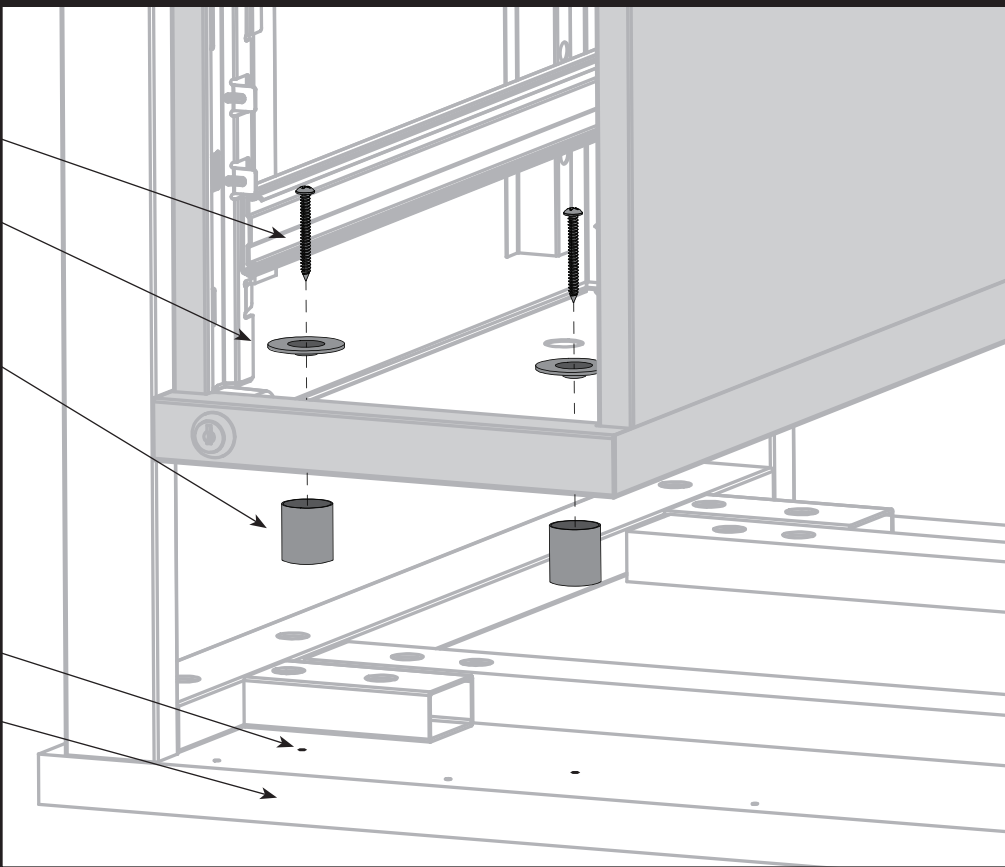

**FIGURE 4**

- Long Screw
- Cup Washer
- Standoff
- Work surface

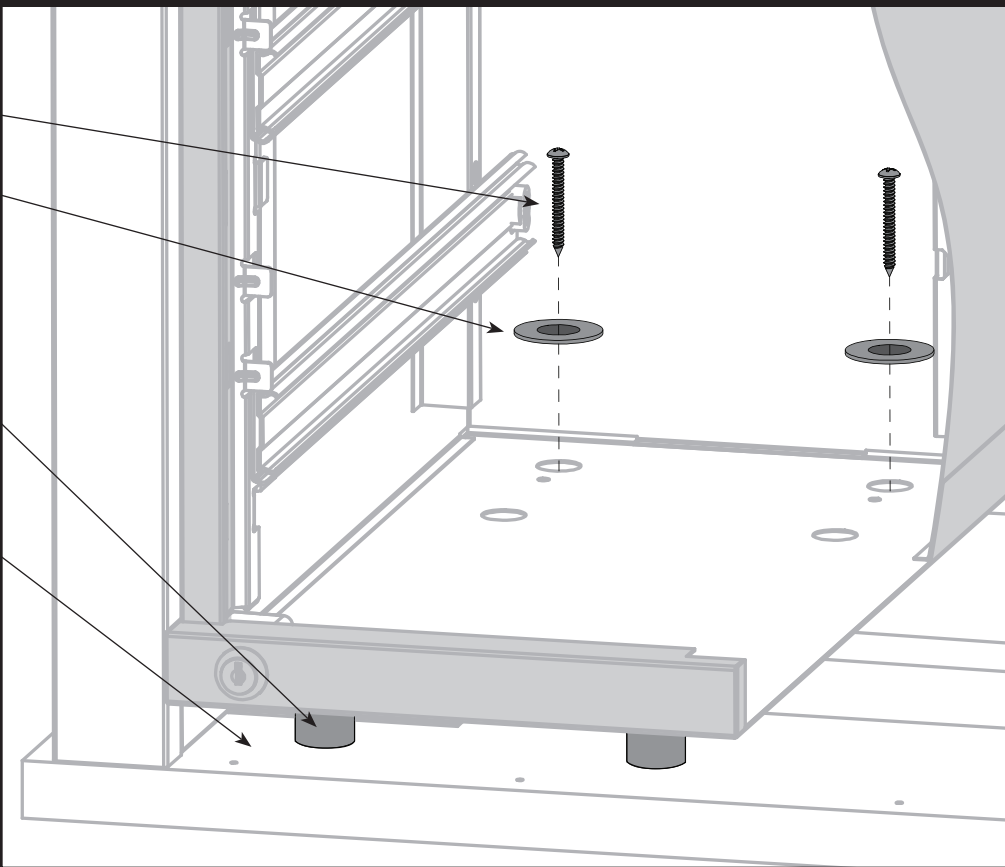

# Hanging Slim Pedestal Mounting Template

