

Ax6 





Fx3 

Bx6 

Cx6 

Dx1 

1



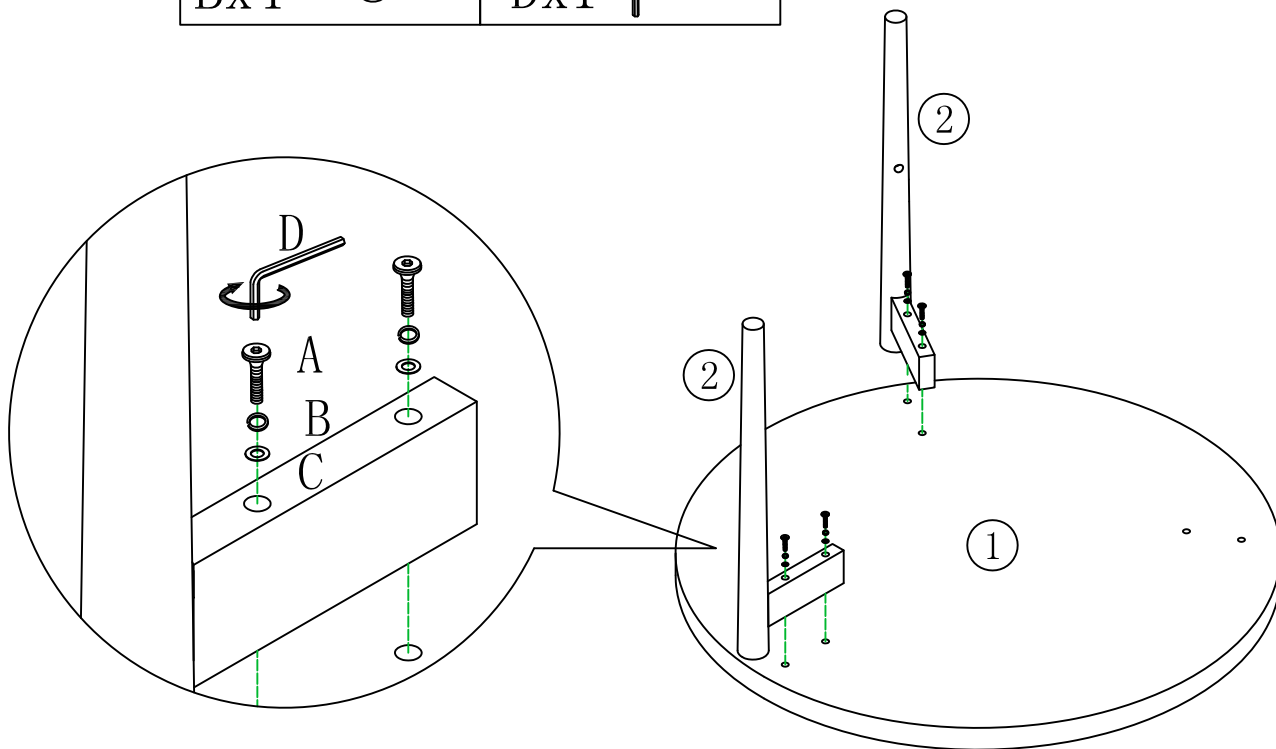

Ax4		Cx4	
Bx4		Dx1	

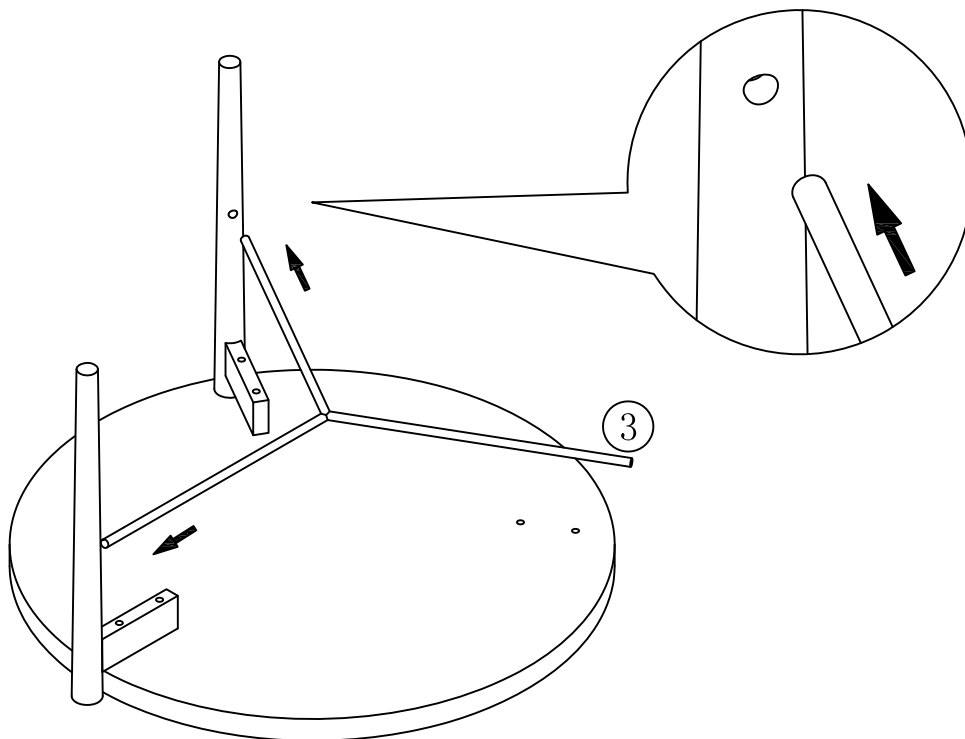

2



3

Ax2		Cx2	
Bx2		Fx3	

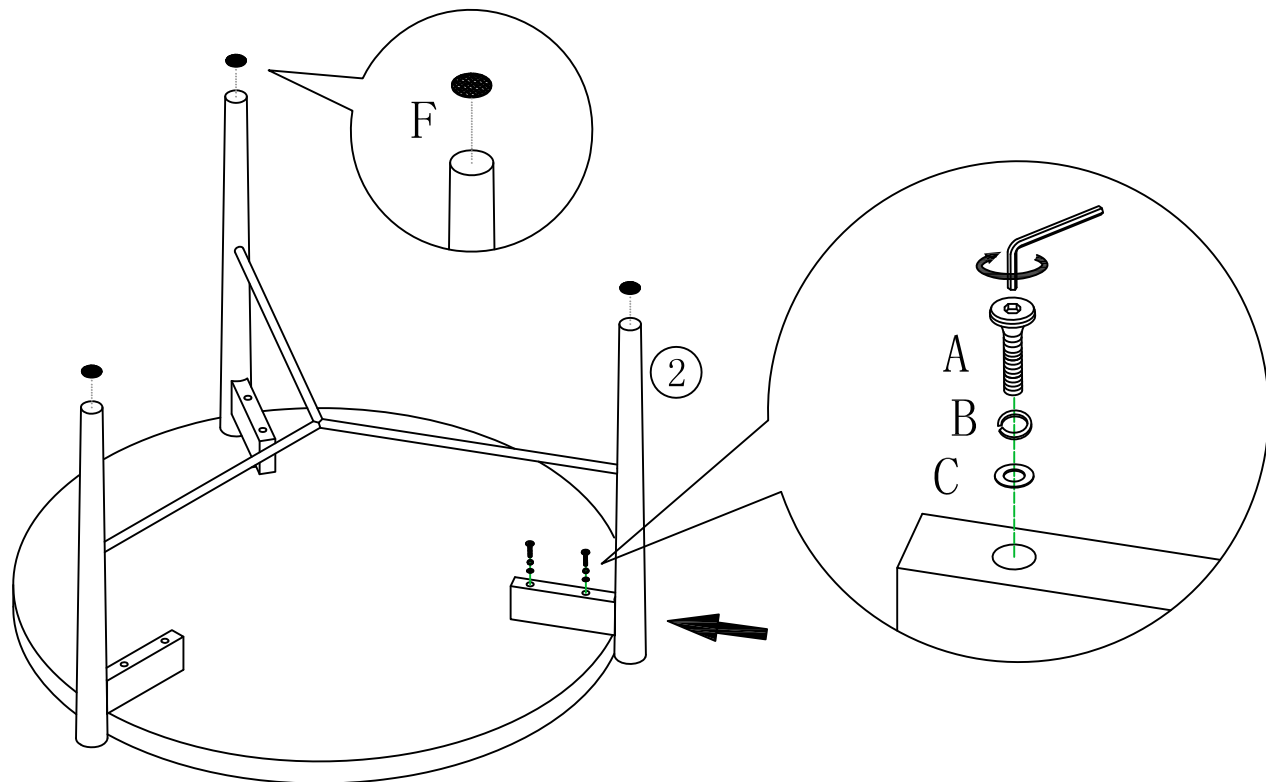

4

