

ADCRAFT®



DF6LS, DF6L2S Electric Fryers Instruction Manual

This manual contains important information regarding your Adcraft unit. Please read this manual thoroughly prior to equipment set-up, operation, and maintenance. Failure to comply with regular maintenance guidelines outlined in this manual may void the warranty.

WARNINGS

DF6LS model supplied with one power supply cord, DF6L2S model supplied with two separate power supply cords, please plug in two power supply cords for model DF6L2S when operating and must unplug two power supply cords for model DF6L2S during movement, testing, or repair of the product.

- Do not touch any hot surfaces
- Do not immerse unit, cord or plug in liquid at any time
- It is recommended that the fryer not be moved when it contains hot oil or any other hot liquid Do not use this unit for anything other than intended use
- Do not use outdoors
- Always cook on a firm, dry and level surface
- High temperature will cause scalding. Do not stand over fryer when operating and do not touch any part of machine while in operation, other than handle of basket and power controls
- Do not use unit with a damaged cord or plug, in the event the appliance malfunctions, or has been damaged in any manner
- Keep children and animals away from fryer
- Any incorrect installation, alterations, adjustments, and/or improper maintenance can lead to property loss and injury. All repairs should be done by authorized professionals only
- Keep all flammable and combustible materials away from this unit
- This machine must be placed on a level surface
- Volume of food should be limited to avoid overflowing
- Foods that do not absorb oil easily should be limited to avoid overflow
- Use caution when placing large foods in fryer
- When transporting the unit, the machine should be handled carefully, and held by the side handles.

FEATURES

1. These fryers are available in 2 different models. One is a 1-tank fryer (DF6LS); another is a 2-tank fryer (DF6L2S). The 2-tank fryer is able fry two different kinds of foods at the same time.
2. The oil temperature is regulated by the temperature regulator and includes a yellow (hot light) which cycles on and off to indicate when the desired temperature has been reached.
3. The automatic shut-off feature cuts power to the unit when the oil has reached 446°F (the maximum allowable temperature).
4. There is an automatic micro-switch on the bottom of the unit head. This will cut power to the unit if the head has been separated from the base of the unit without the power switch turned off or the power cord unplugged.
5. The stainless steel tank is removable for easy cleaning. It also has calibration marks for filling with oil.
6. The heating coils are protected by a stainless steel panel base at the bottom of the unit.

TO USE

For model DF-6L2S, individual branch circuits are to be employed to supply the product.

1. Make sure the power supply you are using is adequate for continual fryer use and voltage is adequate. The use of a surge protector or circuit breaker is advisable.
2. Make sure that the temperature regulator knob is set to the off position.
3. Remove basket from the machine.
4. Fill oil receptacle with vegetable oil somewhere between the minimum and maximum levels, allowing room for food volume.
5. Plug the machine in.

Note: DF6LS model supplied with one power supply cord, DF6L2S model supplier with two separate power supply cords, please plug in two power supply cords for model DF6L2S when operating.

6. A green "Power Light" will come on. Rotate the temperature regulator knob clockwise to the desired temperature. When the desired temperature has been reached, the yellow "Hot Light" will turn off and cycle, and the temperature controller will maintain the temperature automatically.
7. Load food into basket, and carefully place loaded basket into machine to avoid splash.
8. Gently shake off excess oil from food when removing from tank after frying.
9. The enclosed frying basket is intended to hold small foods such as French fries and onion rings. Large food can be placed directly into the basket or oil tank.

CLEANING – NOTE:

- After fryer usage, turn power controller counterclockwise to the "OFF" position and remove plug from power supply.
- Please note DF6LS model supplied with one power supply cord, DF6L2S model supplier with two separate power supply cords, please unplug two power supply cords for model DF6L2S when cleaning.
- Wait for oil to fully cool down before removing tank from outer case.

The procedure is as follows:

1. Carefully remove unit head from box and place in a safe dry place.
 2. Lift out the tank and carefully dispose of oil
 3. Gently wash oil tank with soap and water. Dry completely and place back on machine
-
- For best results, cover the fryer when oil is cool and not in use. This will keep unwanted debris from falling into the oil.
 - For best results, always use fresh vegetable oil with each use. It is recommended that you inspect the unit before each use to check that the power cord is not frayed or damaged in any way.

CIRCUIT DIAGRAM

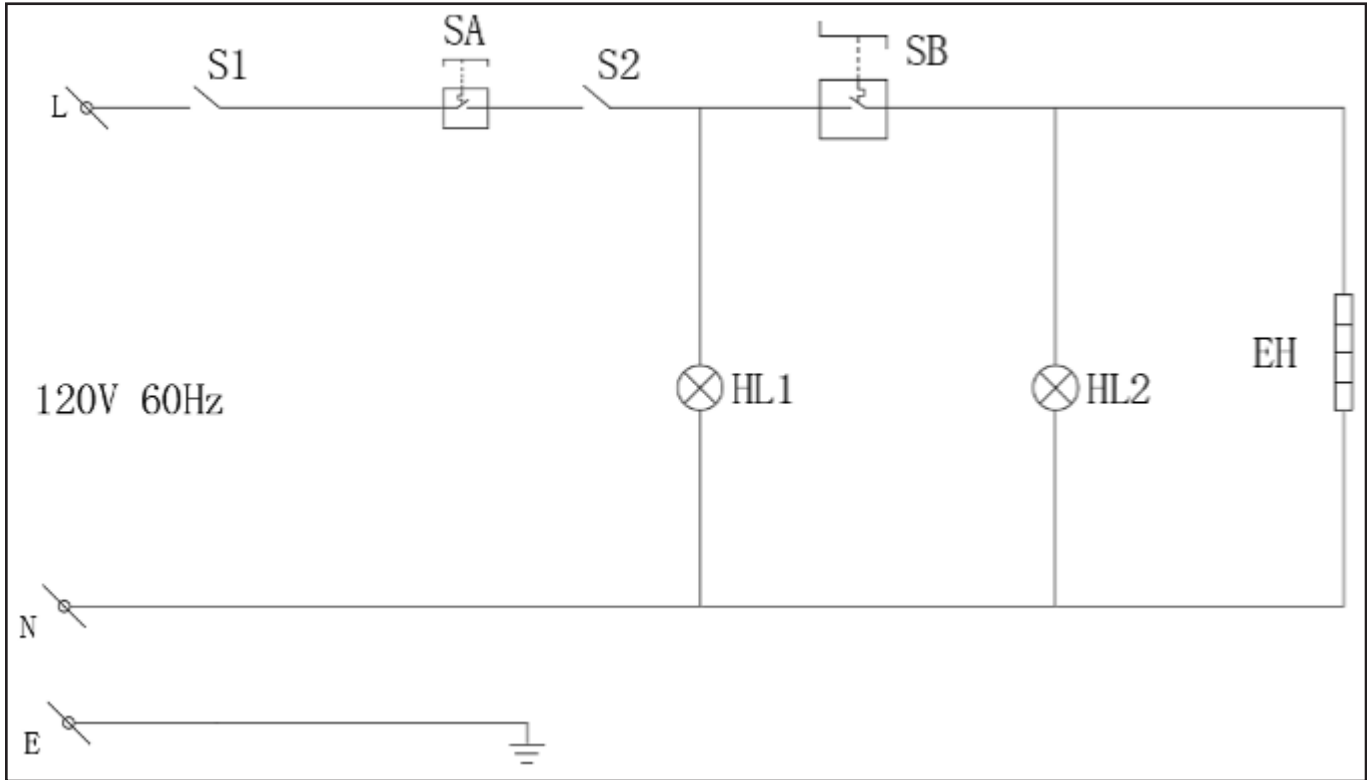

S1 - Power switch
 SA - Overheat switch
 EH - Heater element
 HL1 - Power-on indicator

HL2 - Heater-on indicator
 SB - Thermostat
 S2 - Micro-switch

Note: the circuits of the two fryers are identical. The difference is that the two-tank fryer has two separate electrical unit boxes and receptacles.

TROUBLESHOOTING

Troubles listed are for reference. If any fault occurs, please discontinue use. Do not attempt to repair yourself. This will void the warranty.

PROBLEM	CAUSE	SOLUTION
Not working as well as expected	Unit is not on a dedicated circuit	Unplug unit, plug into a dedicated line and retry
	Basket is overloaded	Too much product will bring down the temperature of the oil bringing it to a boil rather than a frying temperature. Use less product.
Stopped working	Reset button was tripped	There is a reset button located on the back of the head. Unscrew the cap and push the button to reset. (Be sure to replace black cap)
	Micro/safety switch is not making contact	Make sure that the unit is on a level surface and that switch is sitting flush making contact with the metal on the back of the body
Indicator light won't turn on and unit will not heat	Plug not properly inserted into outlet	Reinsert the plug

TO RESET

Located on the bottom of the fryer head, it will read "Reset"



With the unit unplugged and fully cooled off, unscrew the knob to expose red button



Press red button in to reset

DF6LS EXPLODED DRAWING

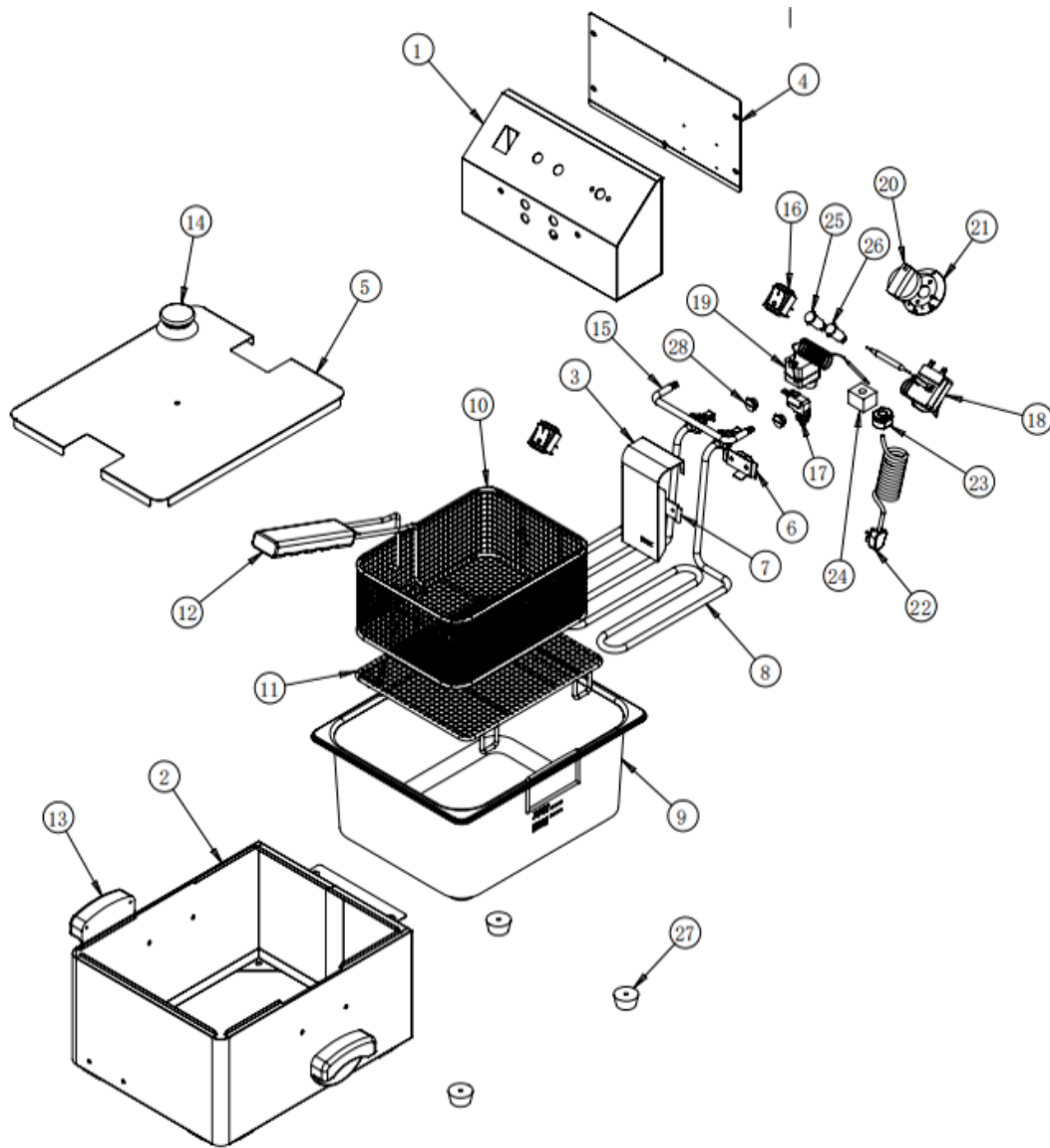

DF6LS PART LIST

NO.	DESCRIPTION	QTY.
1	Fryer head	1
2	Shell assembly	1
3	Heat element cover	1
4	Back cover	1
5	Tank cover	1
6	Heat element support	1
7	Bracket	1
8	Heat element	1
9	Tank	1
10	Basket	1

NO.	DESCRIPTION	QTY.
11	Rack	1
12	Basket handle	1
13	Bakelite handle	2
14	Knob of tank cover	1
15	Hanger rod of basket	1
16	Micro-switch	1
17	Power switch	1
18	Thermostat	1
19	Hi-limit	1
20	Knob of thermostat	1

NO.	DESCRIPTION	QTY.
21	Dial plate	1
22	Power supply cord	1
23	Lock, power supply cord	1
24	Terminal, ceramic	1
25	Power indicator	1
26	Heating indicator	1
27	Foot	4
28	Seal lock	4

DF6L2S EXPLODED DRAWING

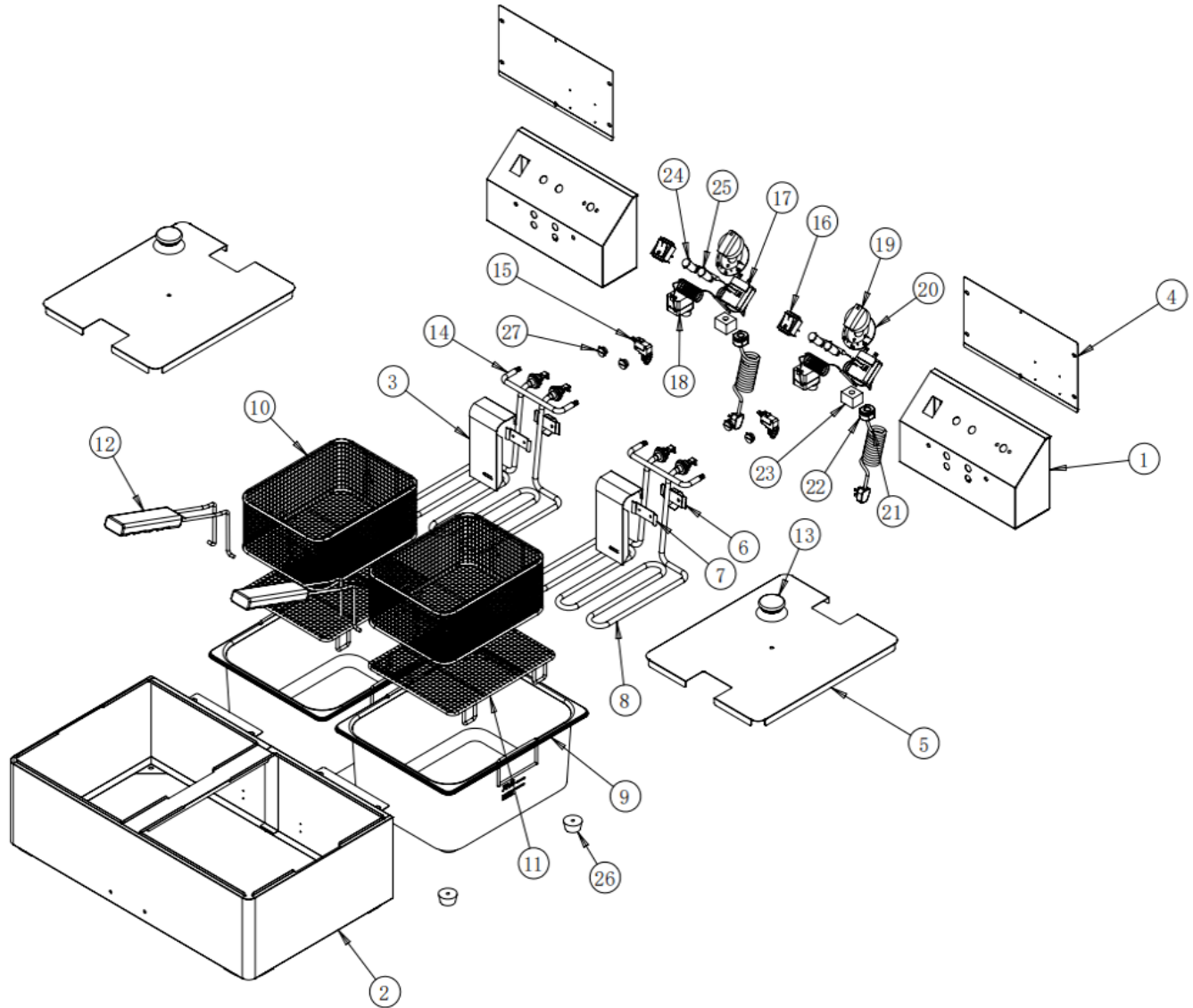

DF6L2S PART LIST

NO.	DESCRIPTION	QTY.
1	Fryer head	2
2	Shell assembly	1
3	Heat element cover	2
4	Back cover	2
5	Tank cover	2
6	Heat element support	2
7	Bracket	2
8	Heat element	2
9	Tank	2

NO.	DESCRIPTION	QTY.
10	Basket	2
11	Rack	2
12	Basket handle	2
13	Knob of tank cover	2
14	Hanger rod of basket	2
15	Micro-switch	2
16	Power switch	2
17	Thermostat	2
18	Hi-limit	2

NO.	DESCRIPTION	QTY.
19	Knob of thermostat	2
20	Dial plate	2
21	Power supply cord	2
22	Lock, power supply cord	2
23	Terminal, ceramic	2
24	Power indicator	2
25	Heating indicator	2
26	Foot	4
27	Seal lock	8

1-YEAR LIMITED WARRANTY

Admiral Craft Equipment Corp. (the "Company") warrants this product (the "Product") will be free from failures in material and workmanship for one (1) year from the date of original purchase with proof of purchase, provided that the Product is operated and maintained in conformity with the Owner's Manual. This Limited Warranty is non-transferable. During this period, your exclusive remedy is repair or replacement without charge of the Product or any component found to be defective at the Company's discretion. If the Product or any component is no longer available, the Company will replace it with a similar one of equal or greater value. This Limited Warranty is void if the Product is used with voltage other than 120 Volts. **THIS WARRANTY IS IN LIEU OF ALL IMPLIED WARRANTIES, INCLUDING WARRANTIES OF MERCHANTABILITY, FITNESS FOR A PARTICULAR PURPOSE, PERFORMANCE, OR OTHERWISE, WHICH ARE HEREBY EXCLUDED. IN NO EVENT SHALL THE COMPANY BE LIABLE FOR ANY DAMAGES, WHETHER DIRECT, INDIRECT, INCIDENTAL, FORSEEABLE, CONSEQUENTIAL, OR SPECIAL ARISING OUT OF OR IN CONNECTION WITH THIS PRODUCT INCLUDING DAMAGES ARISING FOR FOOD OR BEVERAGE SPOILAGE CLAIMS.**

You may have other legal rights depending upon where you live. Some States or Provinces do not allow limitations on warranties so the foregoing may not apply to you.

WARRANTY EXCLUSIONS

IMPROPER ELECTRICAL CONNECTIONS:

The Company is not responsible for the repair or replacement of failed or damaged components resulting from electrical power failure, the use of extension cords, low voltage, or voltage spikes to the Product.

IMPROPER USAGE:

This Limited Warranty does not cover failure or other damages to the Product resulting from (i) improper usage or installation or failure to clean and/or maintain the Product as set forth in the Owner's Manual; or (ii) accident, misuse, abuse, negligence, or modification or alteration of the Product.

CONSUMABLES:

This Limited Warranty does not include consumables or wear-and-tear items such as legs, feet, plastic component parts, splash shields, filters, gaskets, and non-stick cooking surfaces.

ADJUSTMENTS & CALIBRATIONS:

Leveling, tightening of fasteners, or utility connections normally associated with the original installation are the responsibility of the dealer, installer, or the end user and not the responsibility of the Company and will not be considered warranty issues.

If you think the Product has failed, or requires service, within its warranty period, please contact the Company's Customer Care Department through our website at: www.admiralcraft.com "Service" --> "Technical Support Request". A receipt proving the original purchase date will be required for all warranty claims, handwritten receipts are not accepted. You may also be required to return the Product for inspection and evaluation. Return shipping costs are not refundable. The Company is not responsible for returns lost in transit.

This Limited Warranty is Valid only in the USA and Canada.