

# LUXURY GELCOAT SERIES

## SUBMITTAL DATA

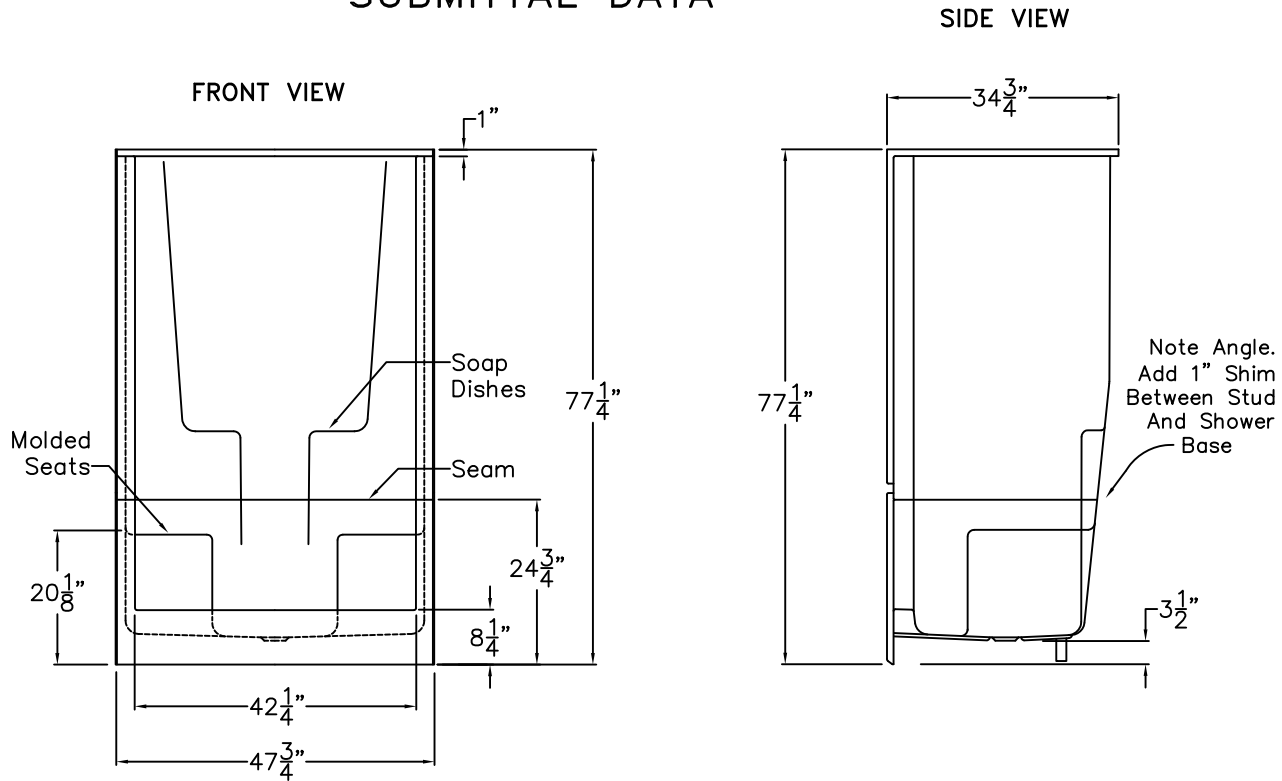

TOP VIEW

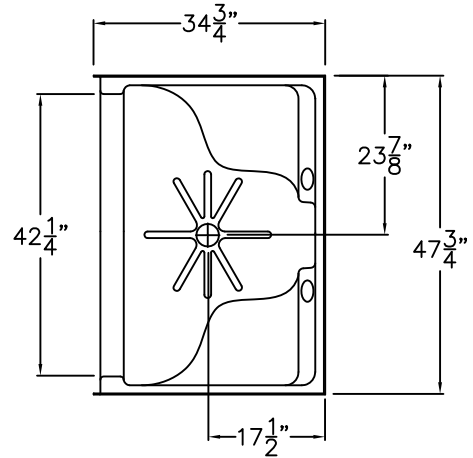

### Sectional Gelcoat Shower

The shower enclosure shall be Praxis Model SKD385 2 piece center. Finished surface shall be of a sanitary-grade polyester Gelcoat exhibiting a minimal thickness of 15 dry mils, and a finished cured Barcol hardness of 80-90 as tested with ASTM D-2583. Unit construction shall be of molded reinforced fiberglass with a 15% minimum fiberglass content. The base shall be attached to the sump of the unit in such a manner to form an integral part with an inner and outer coating of reinforced polyester resin. The unit shall meet HUD, FHA, BOCA, CSA B45.5, IAPMO Z124-11, Home Innovation Research Lab, UPC, and shall meet the requirements of the Southern Building Code.

The unit shall have outside dimensions of 47 3/4" x 34 1/4" x 77 1/4".

The enclosure shall be equipped with the following factory installed accessories:

- 1) Molded seats,
- 2) Molded soap dishes,
- 3) Two piece sectional design,
- 4) Above floor rough-in,
- 5) 8 1/4" Threshold.

DUE TO THE NATURE OF THE MATERIALS  
DIMENSIONS MAY VARY ± 1/2"

Model:	<b>PRAXIS</b>	
Approved by Print Name:	Drawing#: SKD385 2P	
Approved by Signature:	Date Approved:	Date: 7-18-96    Revised: 6-4-14
Rep.:	Wholesaler:	Quote No.:

PRAXIS INDUSTRIES, INC.  
435 INDUSTRIAL RD - SAVANNAH, TN 38372  
1 (800) 443-7269 - FAX (901) 925-4290