

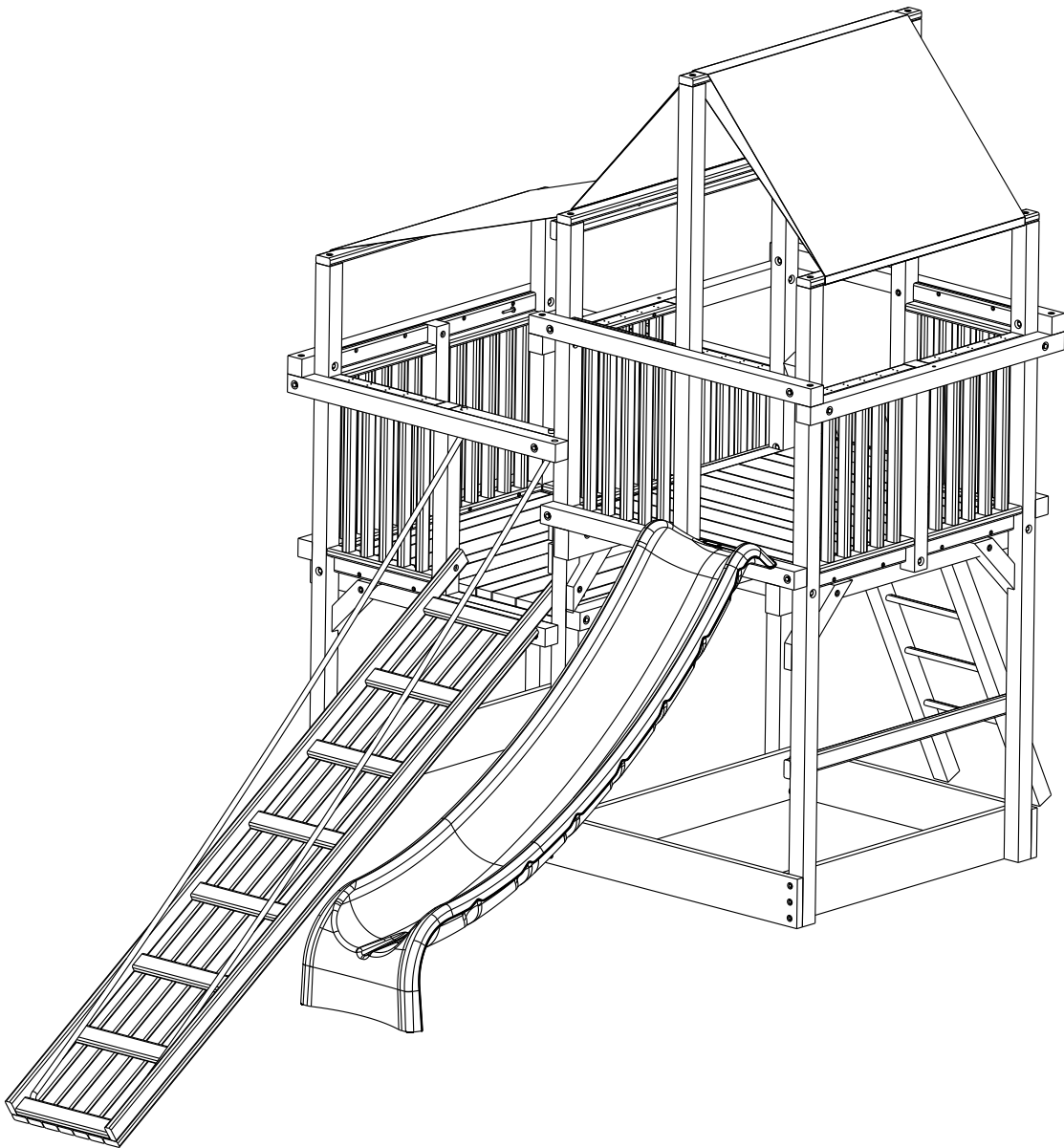

Climbing Ramp Instructions



Every day is a great day in Woodplay.™

2101 HARROD STREET • RALEIGH, NC 27604 • 800/982-1822 • 919/875-4499 • FAX 919/875-4264 PA-MAN-LBAR-00

©2010 Woodplay. All rights reserved.

CLIMBING RAMP INSTALLATION

RW-FIL-029-007

28 1/2" Ladder Filler Assembly

1. Attach Ladder Filler Assembly as shown in Detail 1.
2. Attach Ramp to the playset with two 3/8" X 3" Lag Screws as shown in Detail 3.
3. Attach 25" Ramp Rope block from the inside to safety rail with two 3/8" X 5 1/2" Lag Screws as shown in Detail 2.

4. Insert ropes up through ramp blocks and tie a double knot on top of ramp block.

5. Tie a knot every two feet along each rope.

6. Insert ropes down through the holes in the bottom of the ramp. Lift Ramp 1 foot off the ground, pull ropes tight and tie a double knot on the underside of ramp.

3/8" X 5 1/2" LAG SCREW

3/8" Flat Washer

Double Knot

RW-PAN-033-025

Side Panel 25 x 33

3/8" X 5 1/2" LAG SCREW

3/8" Flat Washer

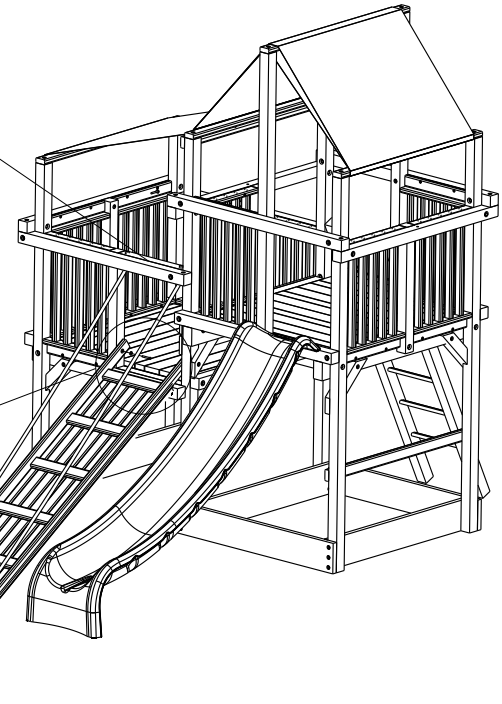
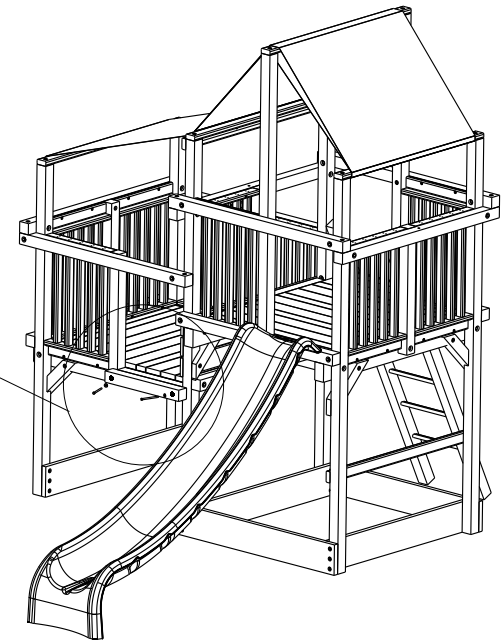
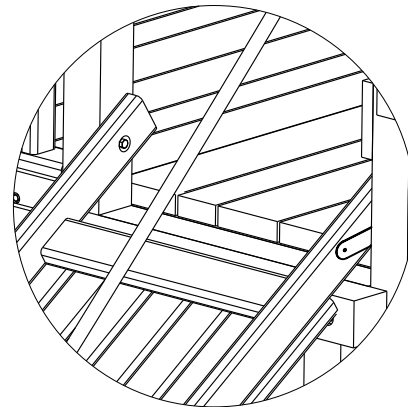
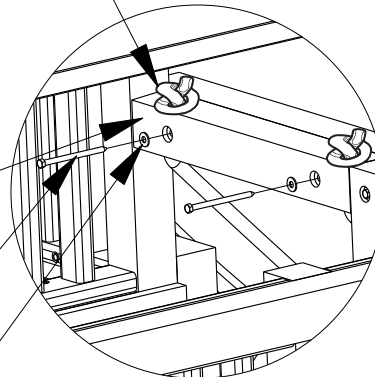
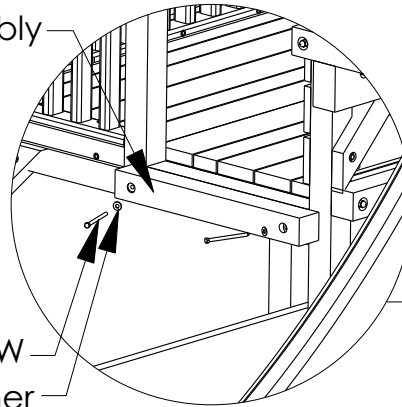

CLIMBING RAMP INSTALLATION

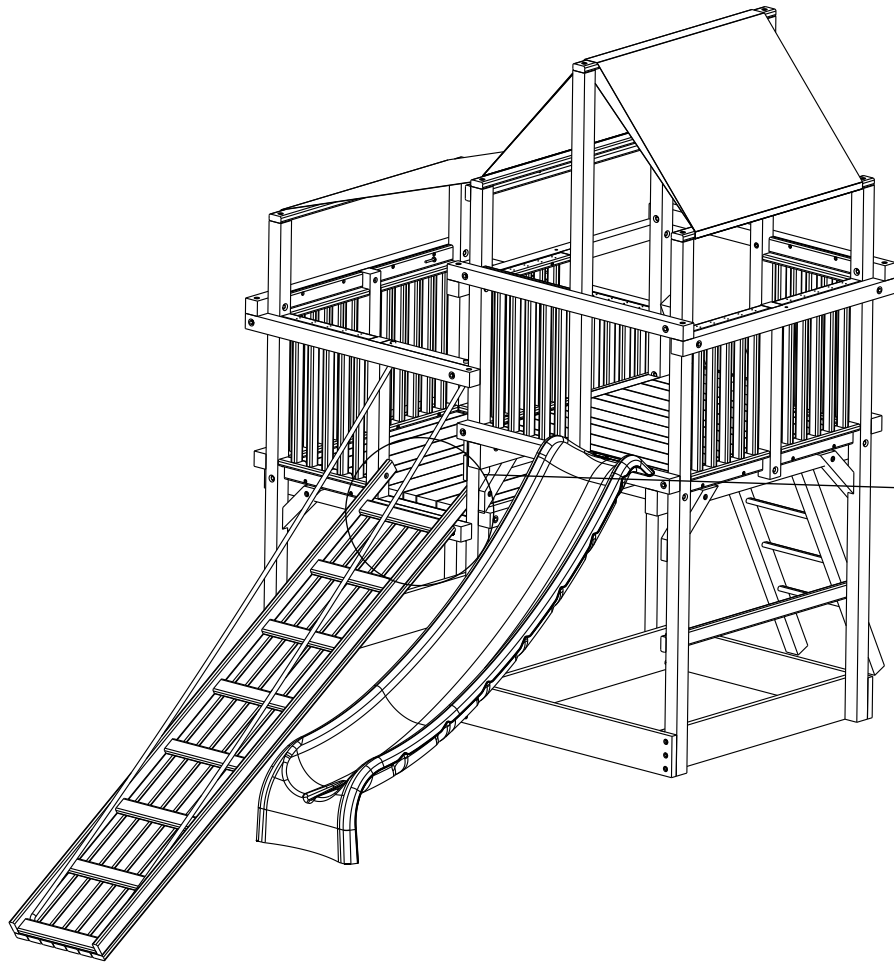

Ladder Lock



Ramp

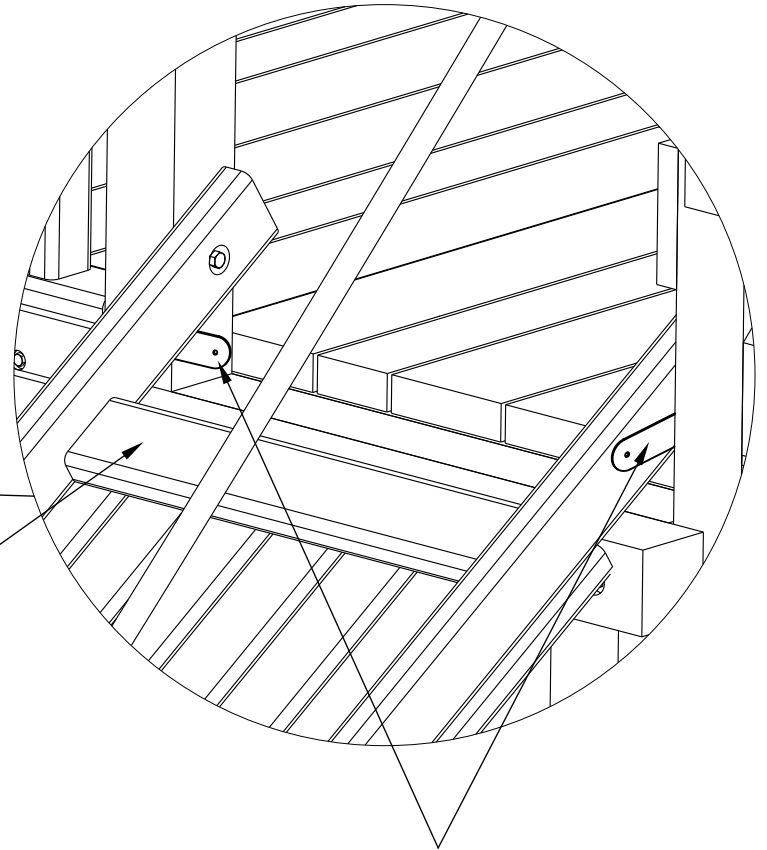

Ladder Locks

7. Attach Ladder Locks to Ramp and Playset with screws provided to keep Ramp from pivoting.



No Kidding Guarantee

30-Day Unconditional Warranty. If, at any time during the first 30 days after the date of delivery, you are not completely satisfied with your Woodplay product, you may return the product (freight prepaid by customer) in its original condition to us for a similar replacement or a full refund of the purchase price, excluding installation expense.

2-Year Warranty on all above-ground Woodplay playset components manufactured by Woodplay suppliers. Woodplay will repair or replace, at our option, any Woodplay above-ground playset component which fails within two years after the date of delivery as a result of a defect in materials or workmanship.

Limited Lifetime Warranty on all above-ground Woodplay wooden playset components, swing hangers, swing chains, metal braces, metal rungs, and our exclusive Super Slide. Woodplay warrants to the original retail customer that we will replace any above-ground Woodplay wooden playset component suffering structural failure due to warping, rotting, or insect damage (excluding carpenter bees). This warranty does not cover knots in the wood, surface cracking or seasonal checking of components. Knots, surface cracking and seasonal checks are a natural characteristic of all wood, including redwood, and will not affect the integrity of your playset. Woodplay warrants to the original retail customer that we will replace any swing hangers, swing chains, metal braces or metal rungs that fail due to rust or breakage (excludes surface rust). This limited lifetime warranty also applies to our exclusive Super Slide. This warranty is expressly in lieu of all other warranties, expressed or implied, including warranties of merchantability or fitness for use. Woodplay does not assume, or authorize any person or representative to assume for us, any other liability in connection with the sale of our products. These warranties exclude any incidental or consequential damages which may arise from the purchase or use of our equipment. Some states do not allow the exclusion or limitation of consequential damage, so the above limitation or exclusion may not apply to you. This warranty program applies only to the original owner and is limited to residential and noncommercial use of the products. Customer must register the playset purchase at www.woodplay.com to be eligible for warranty. A copy of the original invoice must accompany all warranty claims. Freight and labor charges are not included. This warranty program does not cover normal wear and tear, or damages resulting from misuse, abuse, vandalism, alteration, acts of God, or assembly and maintenance contrary to our instructions. Woodplay reserves the right to examine photographs and/or the component itself—shipped freight prepaid by the customer—prior to potential replacement. Questions about this warranty should be addressed to the Customer Service Department at 817 Maxwell Ave., Evansville, IN 47711, or call 1-800-WOODPLAY

Special Note: Woodplay reserves the right to make changes in materials, design, and pricing without notice. See your instruction manual for maintenance requirements. Your child's safety is your responsibility; therefore, you should inspect this equipment regularly for wear and safety.