

### Features

- Two-stage filtration and absorption system
- Reduces Chlorine Taste & Odor, Chloramine, Particulate Class I, Lead, Asbestos, Cyst, Mercury, Turbidity, and select Pharmaceuticals. See Performance Data Sheet for individual contaminants and reduction performance
- Reduces over 95% of perfluorooctanoic acid (PFOA) and perfluorooctane sulfonate (PFOS) in drinking water
- Filter head automatically turns off the water supply when cartridge is removed
- 1.7 gpm (gallons per minute) maximum flow rate at 60 psi
- Eco-friendly coconut shell-based carbon filter
- For use with any kitchen, bathroom or beverage faucets. Recommended beverage faucets Wellspring or Carafe
- Filters cold water only when installed with a kitchen or bathroom faucet
- Includes K-77688 replacement cartridge two-pack

### Material

- High-impact plastic construction

### Installation

- Quarter turn twist cartridge replacement for easy install and replacement

### Recommended Products/Accessories

K-77688 Replacement Filter Cartridges, Two-Pack



### Codes/Standards

CSA B483.1  
NSF/ANSI 42  
NSF/ANSI 53  
NSF/ANSI 401  
NSF Protocol P473  
IAPMO Certification

### KOHLER® Water Filter Systems Five-Year Limited Warranty

See website for detailed warranty information.

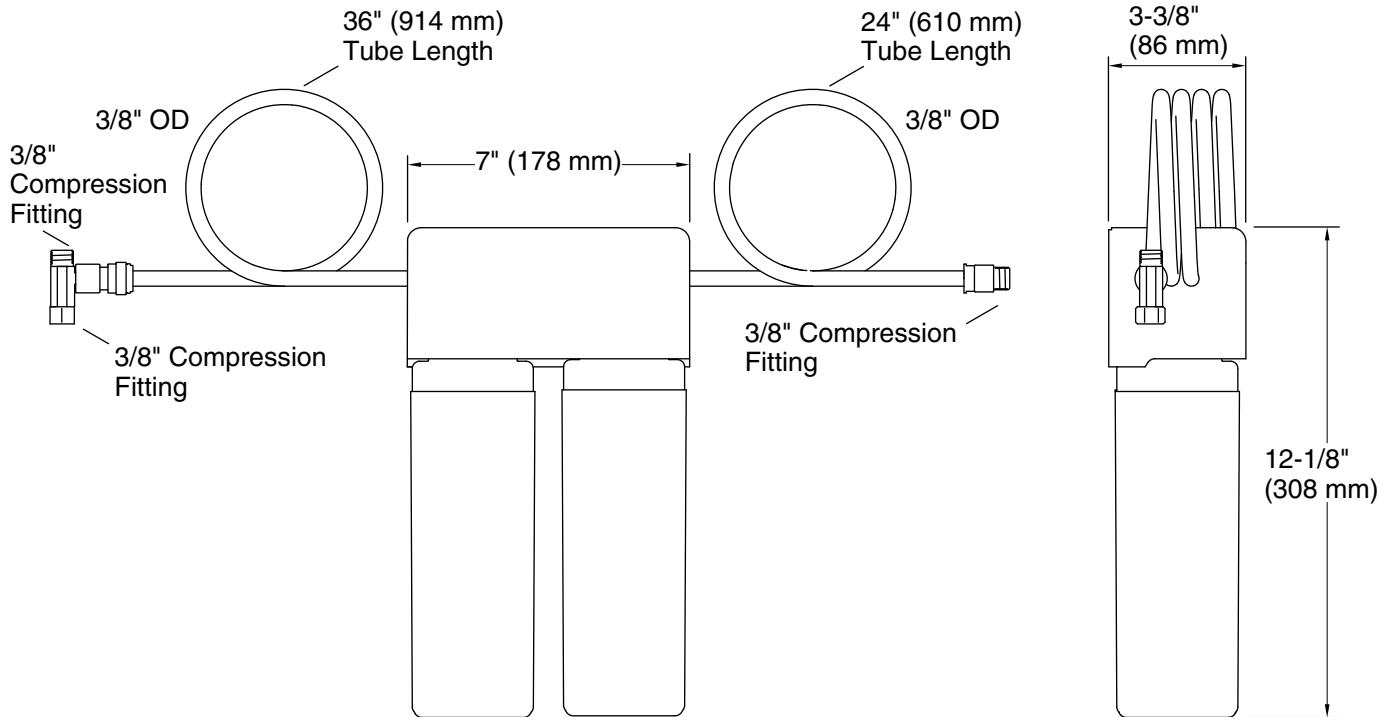

### Technical Information

All product dimensions are nominal.

#### Faucet:

Flow rate: 1.7 gal/min (6.4 l/min)  
 Pressure: 60 psi (4.1 bar)  
 Drain included: No

### Notes

Install this product according to the installation guide.

To prevent the risk of property damage, protect from freezing.

For cold water use only.

To ensure the filter continues to reduce contaminants effectively, it is recommended that the filter gets replaced every 6 months.

Application guideline/water supply parameters:

Water Pressure: 40-120 psi (276-827 kPa)

Water Temperature: 33-100°F (0.5-37.8°C)

Capacity: 778 gal (2,945 L)