

INSTRUCTION MANUAL

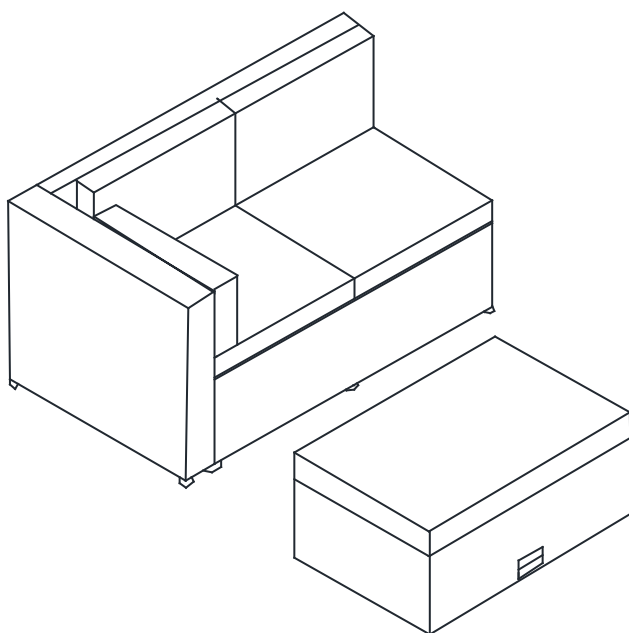

**2-Piece Outdoor Patio Sets
with Cushions
SKU: P152-01-B**

V1.0

! NOTICE

Do not overtighten screws. (Insert all screws before tighten screws.)

- Please do not exceed the weight limitations of this item.
- Do not stand on or use any part of this item as a step ladder.
- Firmly secure all bolts, screws and nuts before use.
- Reconfirm that all bolts, screws, and nuts are secure every 90 days.
- Do not use or store this item in the proximity of open flame or flammable/combustible chemicals.
- Be aware that some parts are heavy and have sharp edges.

TOOLS REQUIRED



ALLEN WRENCH
(PROVIDED)



TABLE
110 LBS
CAPACITY



CORNER SEAT
660 LBS
CAPACITY



1 PERSON
ASSEMBLY



UP TO 60 MIN.
ASSEMBLY

HARDWARE

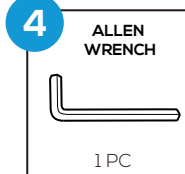
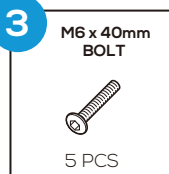
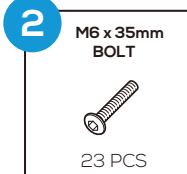
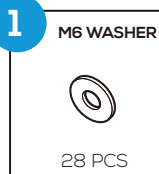

PARTS

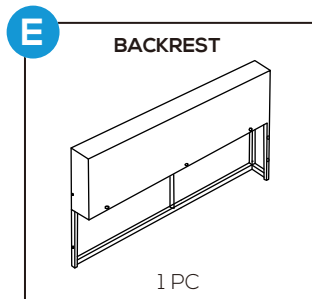
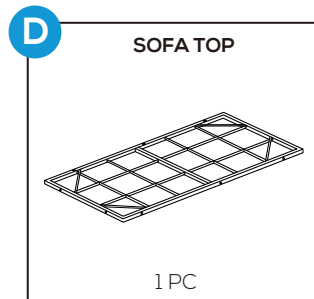
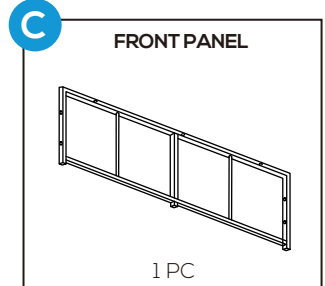
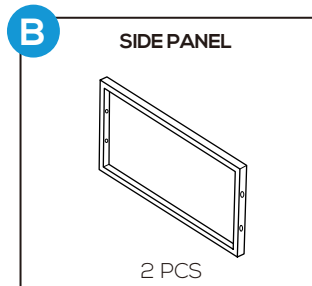
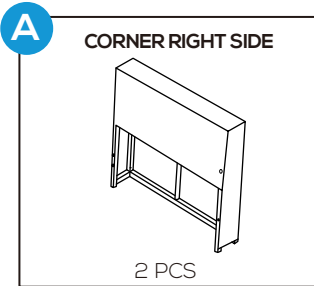

PARTS

F

TABLE BACK PANEL

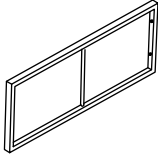

1 PC

G

TABLE TOP

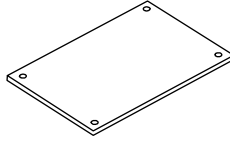

1 PC

H

TABLE BASE

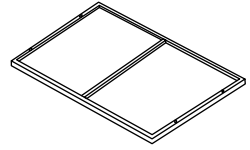

1 PC

I

TABLE FRONT PANEL

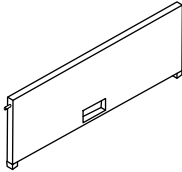

1 PC

J

RIGHT TABLE SIDE

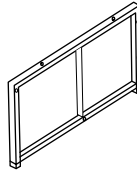

1 PC

K

LEFT TABLE SIDE

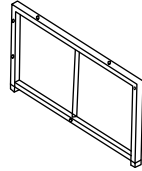

1 PC

GLASS

Y1

GLASS TOP

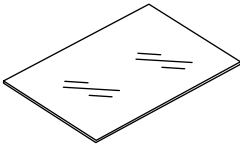

1 PC

CUSHIONS

Z1

SEAT CUSHION

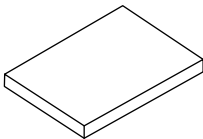

1 PC

Z2

BACK CUSHION

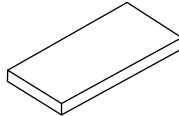

1 PC

Z3

SIDE CUSHION

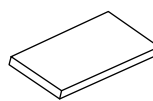

1 PC

Z4

TABLE CUSHION

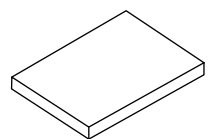

1 PC

PRODUCT ASSEMBLY - CORNER SEAT

1

Attach part A Corner Right side to part E Backrest with 2 PCS of hardware 1 Washer and hardware 2 Bolt.

Do not tighten screws too much at this stage.

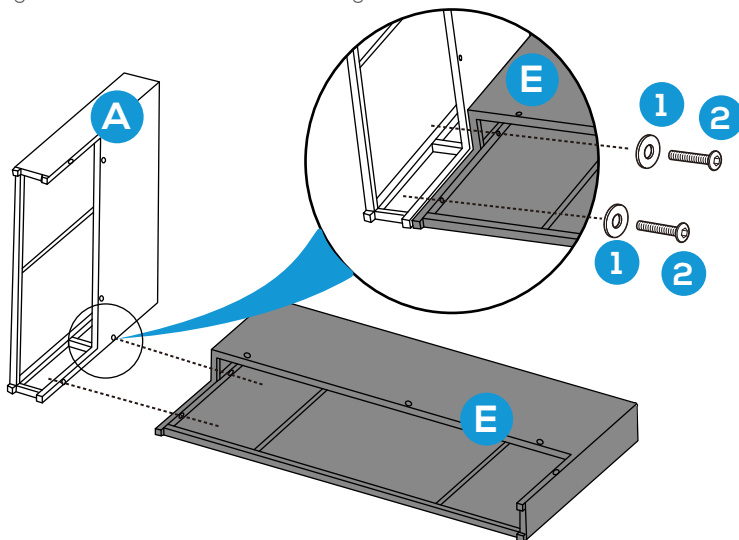

2

Attach part C Front Panel to part D Sofa Top with 3 PCS of hardware 1 Washer and hardware 2 Bolt.

Attach part B Side Panel to part C Front Panel with 2 PCS of hardware 1 Washer and hardware 2 Bolt.

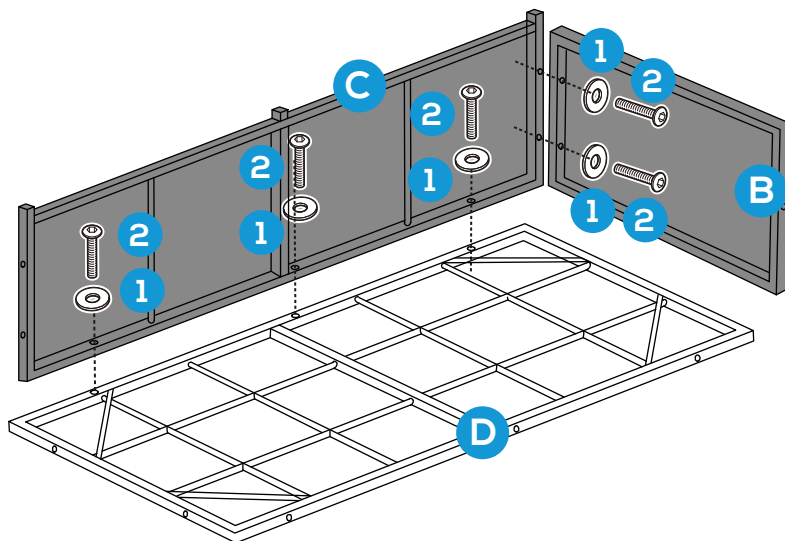

PRODUCT ASSEMBLY - CORNER SEAT

3

Attach the assembled part (B+C+D) to assembled part(A+E) with 5 PCS of hardware 1 Washer and hardware 3 Bolt; 4 PCS of hardware 1 Washer and hardware 2 Bolt as below.

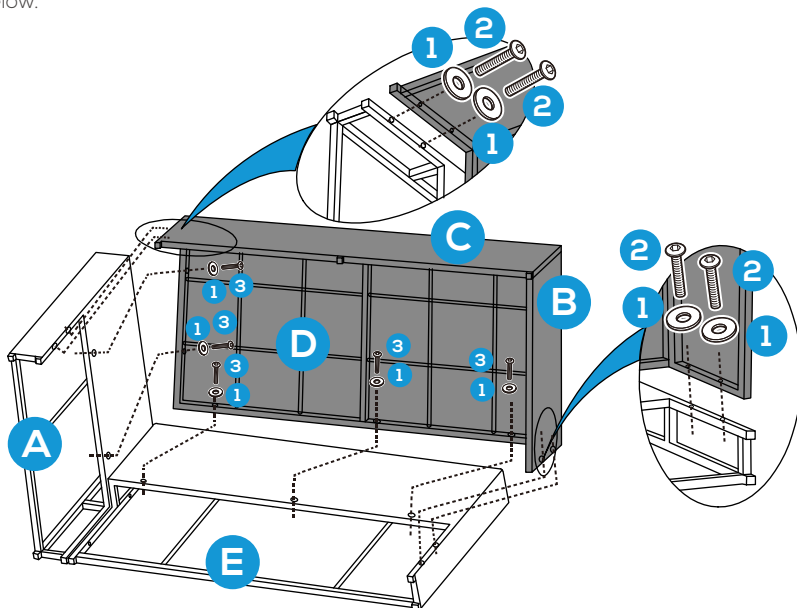

4

Tighten all the screws again to ensure the steady of this corner seat.

Place part Z1 Seat Cushion, part Z2 Back Cushion and part Z3 Side Cushion into the corner seat.

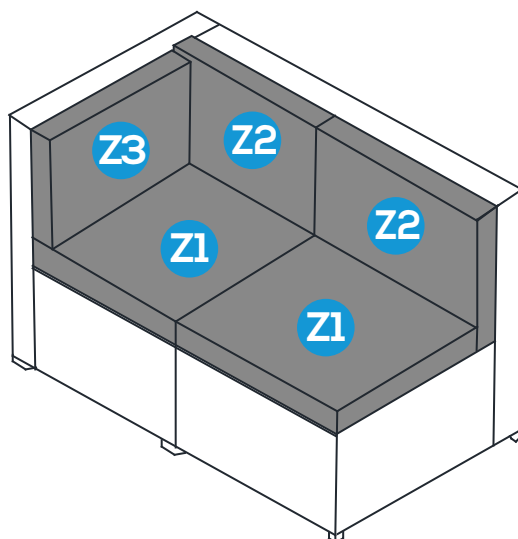

PRODUCT ASSEMBLY - COFFEE TABLE

5

Attach part J Right Table Side to part G Table Top with 2 PCS of hardware 1 Washer and hardware 2 Bolt.

Do not tighten screws too much at this stage.

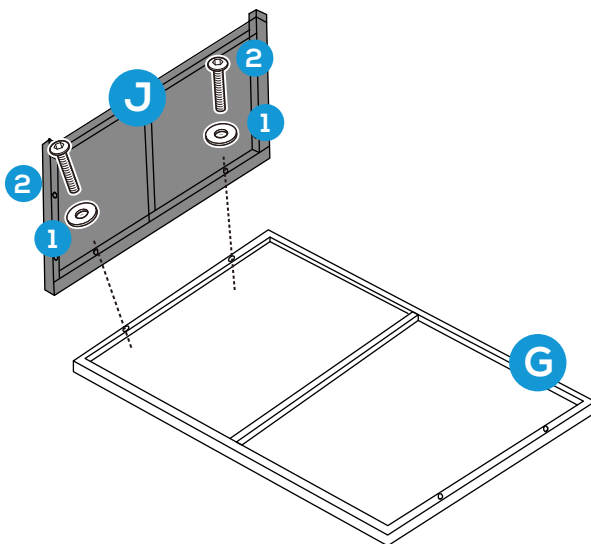

6

Attach part F Table Back Panel to part J Right Table Side and part G Table Top with 2 PCS of hardware 1 Washer and hardware 2 Bolt.

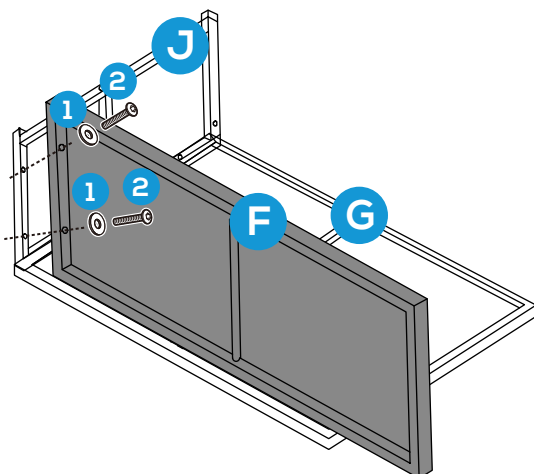

PRODUCT ASSEMBLY - COFFEE TABLE

7

Attach part I Table Front Panel to part J Right Table Side as below.

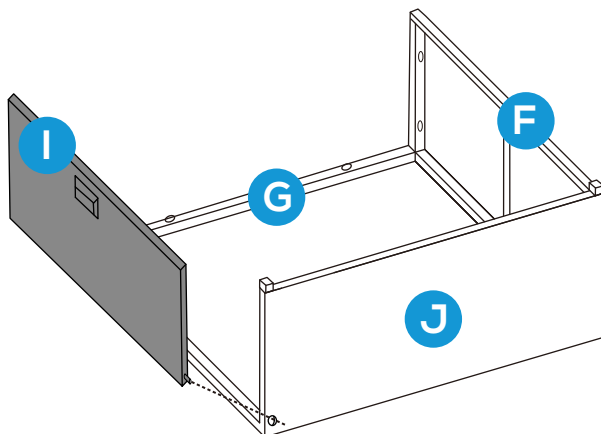

8

Attach part K Left Table Side to part F Table Back Panel and part G Table Top with 4 PCS of hardware 1 Washer and hardware 2 Bolt.

ATTENTION: Attach the steel pin of front Panel into the corner hole of part K Left Table side before assembly.

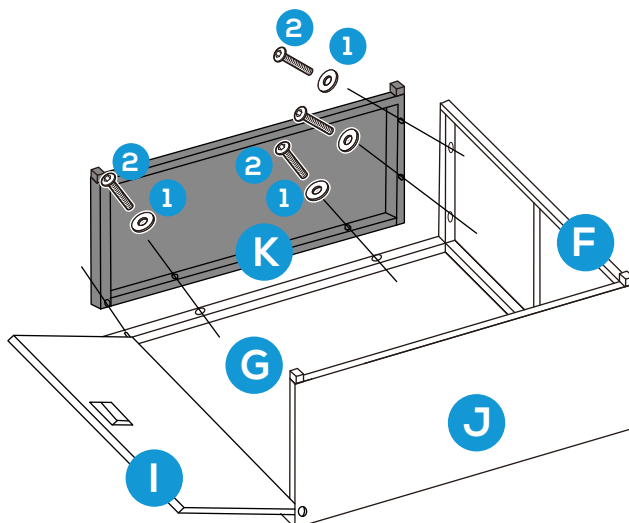

PRODUCT ASSEMBLY - COFFEE TABLE

9

Attach part H Table Base to part F Table Back Panel, part J Right Table Side and part K Left Table Side with 4 PCS of hardware 1 Washer and hardware 2 Bolt.

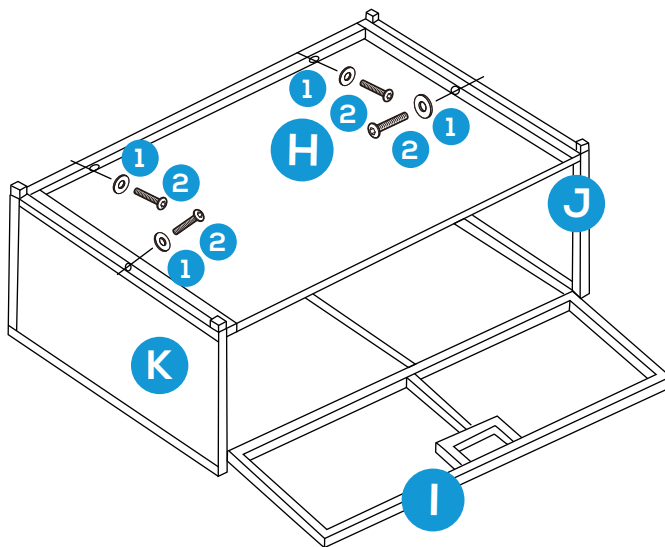

10

Tighten all the bolts again. Turn over the assembled table and place part Y1 Glass Top or part Z4 Table cushion onto part G Table Top.

The Assembly of Coffee Table finishes.

