

INSTRUCTION MANUAL



Outdoor Rocking Poly Adirondack Chair
SKU: 2001-RC

V 3.0

! NOTICE

Do not overtighten screws. (Insert all screws before tighten screws.)

- Please do not exceed the weight limitations of this item.
- Do not stand on or use any part of this item as a step ladder.
- Firmly secure all bolts, screws and nuts before use.
- Reconfirm that all bolts, screws, and nuts are secure every 90 days.
- Do not use or store this item in the proximity of open flame or flammable/combustible chemicals.
- Be aware that some parts are heavy and have sharp edges.
- Please adjust the speed slowly when you use electric drill for assembling to avoid screw slipping.

TOOLS REQUIRED



ALLEN WRENCH
(PROVIDED)



WRENCH
(PROVIDED)



CHAIR
330 LBS
CAPACITY









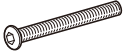

1 PERSON
ASSEMBLY

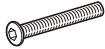
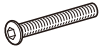

UP TO 30 MIN.
ASSEMBLY

HARDWARE

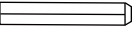
1 M6 x 80mm BOLT  2 PCS	2 M6 x 80mm SCREW  4 PCS	3 M6 x 65mm BOLT  2 PCS	4 M6 x 60mm BOLT  8 PCS	5 M6 x 55mm SCREW  4 PCS
6 M6 NUT  8 PCS	7 M6 WASHER  8 PCS	8 WRENCH  1 PC	9 ALLEN WRENCH  1 PC	10 SCREWDRIVER BLADES  1 PC

PARTS

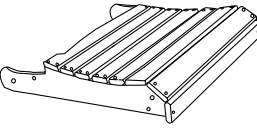
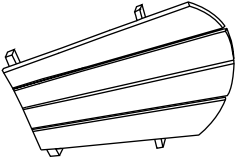
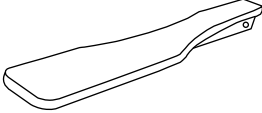
A CHAIR SEAT  1 PC	B CHAIR BACKREST  1 PC	C LEFT CHAIR ARM  1 PC
-----------------------------------------------------------------------------------------------------------------------	---------------------------------------------------------------------------------------------------------------------------	----------------------------------------------------------------------------------------------------------------------------

PARTS

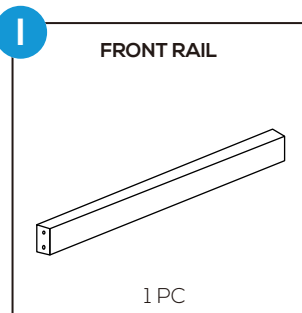
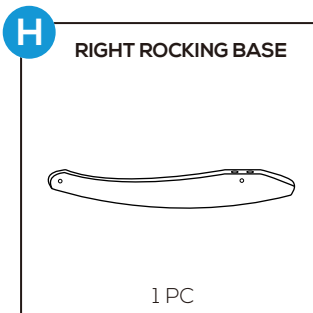
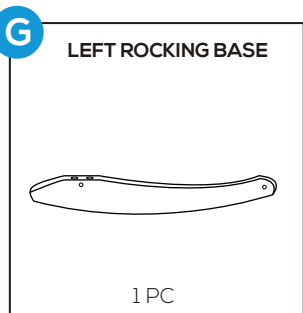
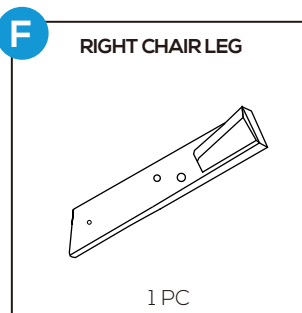
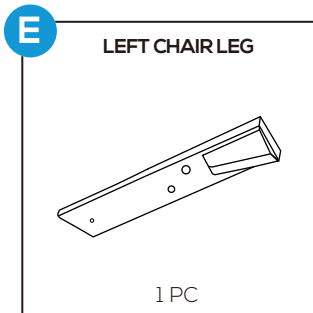
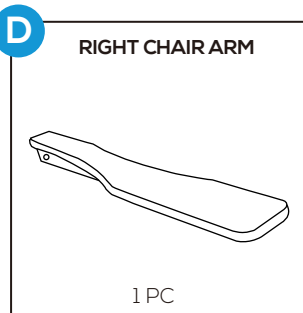

PRODUCT ASSEMBLY - OVERALL VIEW

1

Look at following overall view of this chair and learn the exact position of each parts to be assembled.

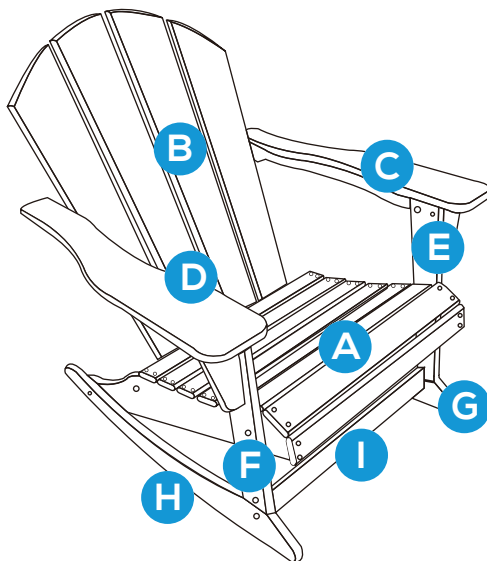

PRODUCT ASSEMBLY

1

Attach part C Left Chair Arm to part E Left Chair Leg with 1 PC of hardware 4 bolt, hardware 7 washer and hardware 6 Nut. Do the same to part F Right Chair Leg and part D Right Chair Arm.

Do not tighten screws too much at this stage.

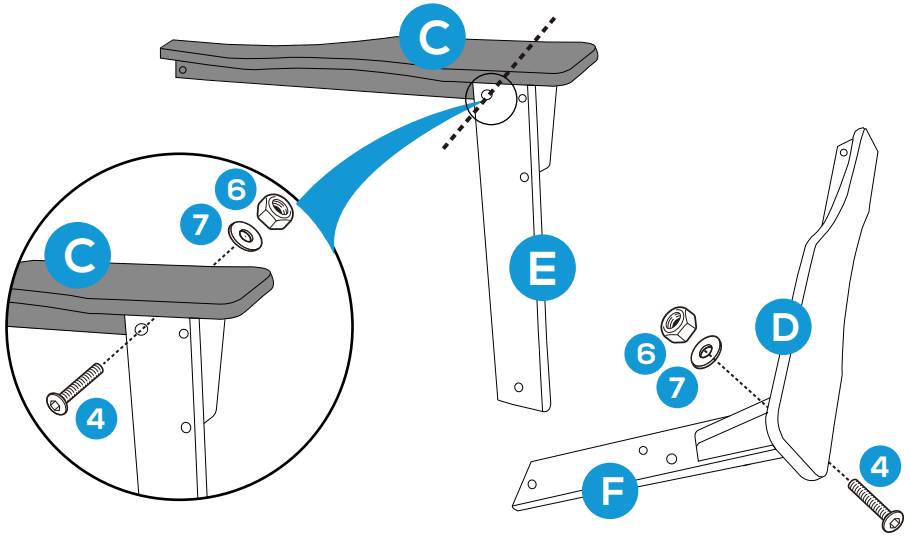

2

Attach part F right Chair Leg and part E Left Chair Leg to part A Chair Seat with 4 PCS of hardware 4 bolt, hardware 7 washer and hardware 6 Nut.

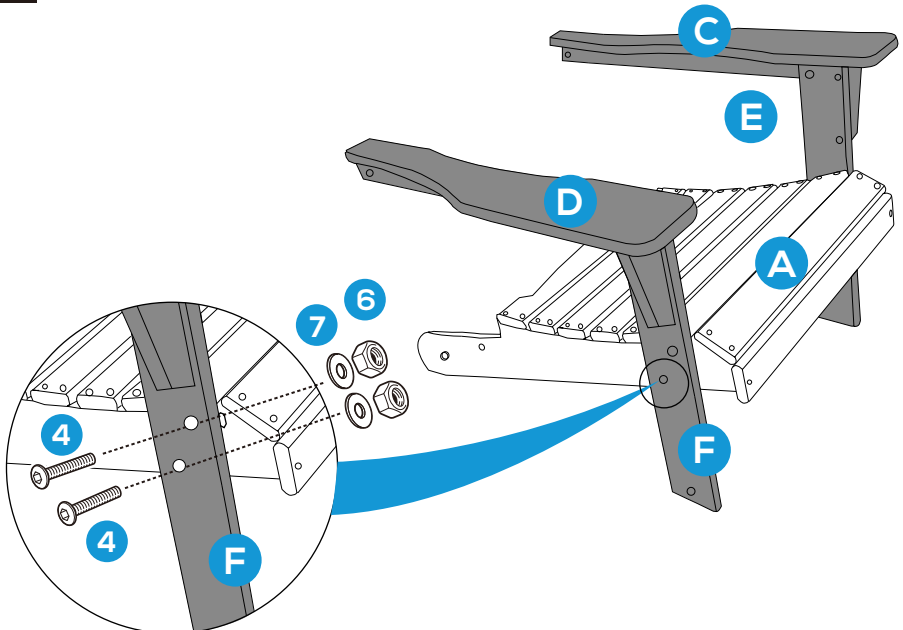

PRODUCT ASSEMBLY

3

Attach part B Chair Backrest to part A Chair Seat and part D Right Chair Arm as well as part C Left Chair Arm with 2 PCS of hardware 1 Bolt and 2 PCS of hardware 4 Bolt as below.

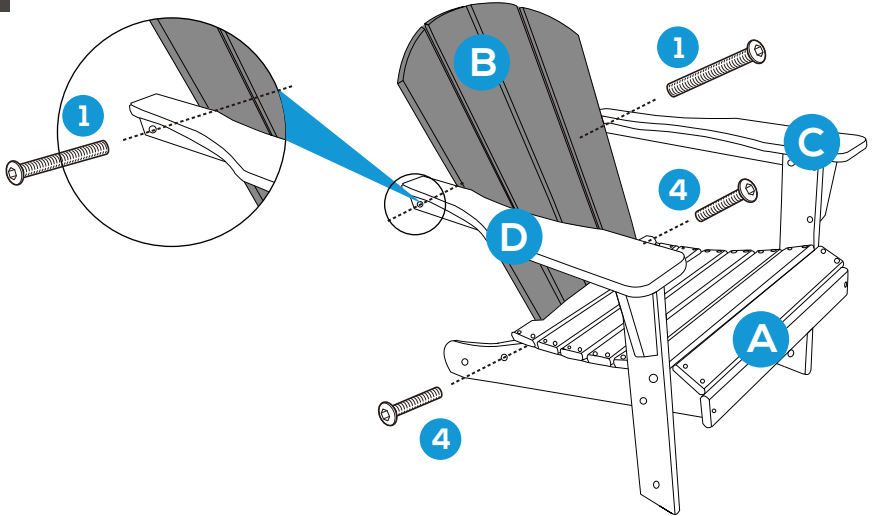

4

Turn the chair upside down, place part G Left Rocking Base to part E Chair Left Leg as below and attach them with 2 PCS of hardware 2 Screw.

Attach part G Rocking base to part A Chair Seat with 1 set of hardware 3 bolt, hardware 7 Washer and hardware 6 Nut.

Do the same to attach part H Right Rocking base.

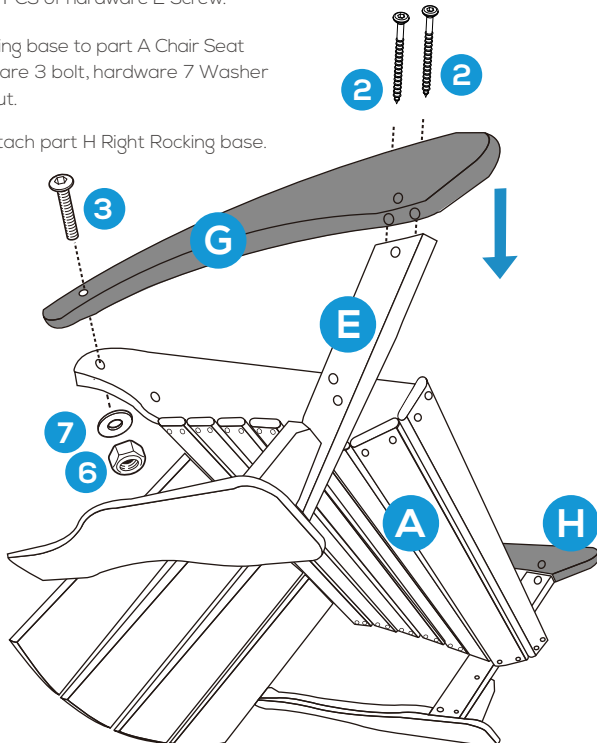

PRODUCT ASSEMBLY

5

Attach part I Front rail to part G Left Rocking base and part E Left Chair Leg with 2 PCS of hardware 5 Screw.

Do the same to the right side to finish the assembly.

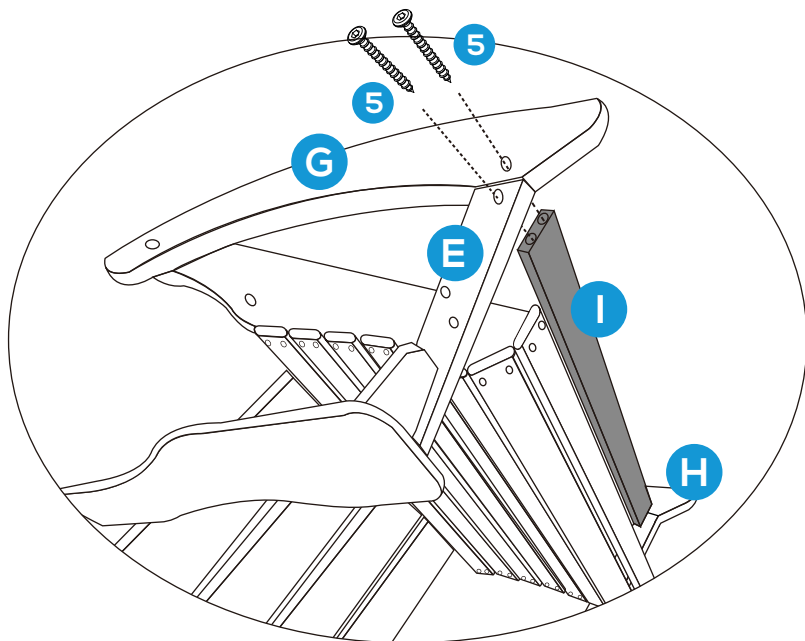

6

Tighten all the screws, bolts and nuts to ensure a steady use of this chair.

