

# clé LAPIDARY

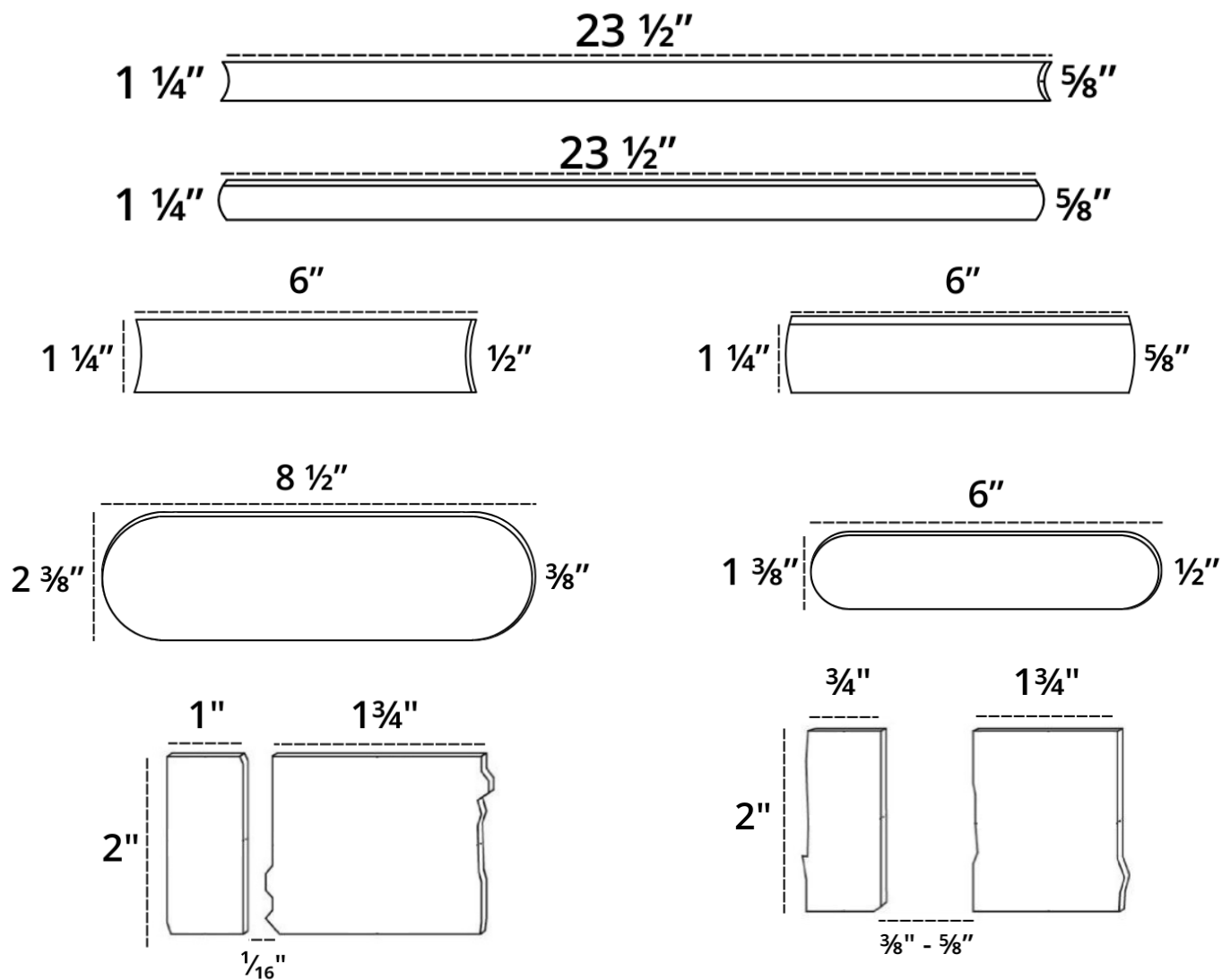

USAGE	walls			floors						traffic rating			
	grout joint	interior	exterior	interior	exterior	entryway	mudroom	bathroom	kitchen	light res.	heavy res.	light comm.	heavy comm.
	1/8"	Y	Y*	Y*	Y*	Y	Y	Y	Y	Y	Y	Y	Y

USAGE	shower		steam shower						resistant		fireplace		
	floors	walls	floors	walls	fountain	pool	waterline	freeze thaw	UV	heat	surround + hearth	backsplash	radiant heating
	Y*	Y*	N	N	N	N	N	N	N	Y	Y	Y	Y*

**standard thickness for lapidary ranges from 3/8" to 5/8"**

please note all dimensions are nominal. please note that dimensions can vary +/- 1/8 inch.

\*there are specific installation requirements for this usage.

please review the "[installation areas](#)" and "[sealing, maintenance & care](#)" sections below and discuss with your installer.

# clé LAPIDARY

---

**you've got something special.** glamorous and sophisticated, clé's lapidary collection features seventeen classic stones – including cararra, limestone, and travertine – in multiple sizes, sculpted shapes and mosaics. these architectural tiles add a note of opulence to any interior to create a classic mood or a more modern sophisticated one, all with a nod to 1970s milan.

**expect variation.** clé lapidary features a variety of natural stones, all of which exhibit degrees of variation. our tiles are cut from large blocks of stone; therefore, there will be variation in both color and shade across production lots or batches, depending on the area of the quarry from which a particular lot was sourced. this means that your sample may not be a perfect match with your actual order, and that your add-on order may not be a perfect match to either. that's the beauty of nature.

---

## INSPECTING YOUR SHIPMENT

- **WHAT TO EXPECT** - clé lapidary tiles are comprised of natural stone which will exhibit a smooth honed surface. ALSO dust and shipping residue should be expected and cleaned prior to installing.
- **BLEND BLEND BLEND** - due to the natural materials and production process of clé lapidary tiles, your order will contain degrees of variation in color, shade, and size. it is crucial that tiles from all boxes are blended and placed in their installation area to ensure you have your desired layout before installing.
- **ORDER EXTRA!** - industry standard suggests adding at least 15% overage due to tile cuts, potential shipping breakage, or future repairs. however, if the variation in color, shade, and veining inherent to natural stone does not fit your project's needs we recommend ordering 25-35% overage, particularly when ordering larger format tiles as blending these can be more challenging. sufficient overage allows your contractor to cherry-pick the tiles most desirable for your project.
- **SHIPMENTS ARE SUBJECT TO WEATHER** - tiles may be exposed to moisture and/or condensation during production or shipping which may affect the color of the tiles once received. setting the tiles out to dry prior to installation will return the color to normal. do not install tiles until fully dried.

---

## INSTALLATION FYIs

- **GENERAL GUIDELINES, NOT INSTRUCTIONS** clé offers general information about our tiles and their unique qualities and usages. proper installation will only be attained if you have selected a seasoned installer with years of experience with artisan tiles. any installer without artisan tile experience will not know how to install clé tiles and will likely result in failed installations.

- **INSTALLATION DEEMS ACCEPTANCE OF YOUR ORDER** if you are not 100% sure of your tiles DO NOT INSTALL THEM. as is standard in the tile industry and with all construction materials, installation deems acceptance of materials. do not install if there are visible issues. if you are unsure of what qualifies as a visible issue for the tile you are installing, please reach out to us PRIOR to installation. Our tiles are subject to variations in color, texture, size, and finish. misuse by contractor or end-user including but not limited to negligence, physical and/or chemical abuse, as well as order shortages ARE NOT a clé responsibility and, therefore, not covered by clé's warranty.
- **TILE IS A MATERIAL. INSTALLATION ERRORS ARE NOT THE FAULT OF THE MATERIAL** - clé tile is a material. Tile is merely the surface of your construction. Installation problems will arise from inexperienced artisan tile installers, substrate, or construction engineering and/or installation issues. please refer to your project architect, structural engineer and/or installer for best results.
- **IT'S NATURAL** - please note that the stones in our lapidary collection contain naturally occurring iron deposits that can cause rust spots if exposed to excessive moisture.
- **PLEASE CONFIRM YOUR INSTALLER'S LEVEL OF ARTISAN TILE EXPERIENCE** - your installation will only be as good as your installer. please visit our blog for tips on [how to choose an installer](https://www.cletile.com/blogs/cle-notes/how-to-choose-contractor-installer) (<https://www.cletile.com/blogs/cle-notes/how-to-choose-contractor-installer>).
- **REQUIRE YOUR INSTALLER PERFORM A "DRY RUN" BEFORE BEGINNING YOUR INSTALLATION** before installing, be sure to lay out and blend tiles from ALL BOXES so that variations in color – as well as tiles that bear chips and pits – are placed as you would like. clé selects our tiles for their hand-hewn variations and inherent surface and color variations. best placement of these nuances within your installation must be guided by you and/or your design professional to realize the best possible blend of our limited-availability tiles. your installation is only as good as your DRY RUN.
- **DO NOT USE TAPE, BLUE TAPE, OR OTHER TAPE** - do not use blue tape or other construction tape during product installation. the tape may erode or damage our products.
- **WAIT UNTIL YOUR PROJECT IS COMPLETE BEFORE INSTALLING YOUR TILES** - install the tiles as late as possible in the project to minimize the risk of damaging the tile.
- **REQUIRE MOCK-UP BOARDS** - to ensure your tiles will be organized properly and your grout joint size and color, as well as your sealant, are done to your design professional's specifications we urge you to require your installer create mock-up boards prior to your installation. a STANDARD PRACTICE for seasoned installers, it lets the end-user and their design professional to test all the tile layouts in mock-up form. also, it allows for the mock-up boards to be examined in the space and lighting in which the tiles will be used. Before beginning the mock-up boards, make sure to FIRST do the above recommended DRY RUN and lay out and blend your tiles as described in that section.
- **"FINAL FINISH" – WHAT IT IS AND WHY MAY YOUR PROJECT REQUIRES THIS?** - if you plan install your tile prior to the installing cabinets, fixtures, etc., you'll need to refinish the tile after those other features are installed, AKA the "final finish." in this step, your contractor should replace any broken or chipped tiles caused by construction damage, scuffing, or any deterioration of the tile surface. they should also hire a professional refinisher for the final refinishing of your tile installation. (\*NOTE – another benefit is that refinishing can lessen common shipping imperfections). be sure to account for this final step in your project timeline and budget.

TCNA and ANSI please refer to the current edition of the TCNA handbook for best installation results and ANSI A137:1 american national standard specifications for ceramic tile to reference specifications.

---

## INSTALLATION AREAS

### ■ walls

- suitable for interior and exterior walls
- for outdoor installations in cold-weather areas there must be a flashing or roofing overhead and the tiles must be sealed with a water-repellent sealer

### ■ floors

- can be used on interior and exterior floors, including areas with light commercial traffic
- for exterior floor installations, clé recommends applying an anti-slip sealer or treatment. in cold-weather areas, they must be installed above-grade on covered decks or verandas and sealed with a water-repellent sealer.
- etui petit, cabochon short, etui grand, and cabochon grand are strictly wall tiles.

### ■ showers

- suitable for use on shower walls and floors
- to increase slip resistance in wet areas, larger tiles can be scored to create grooves on the surface of the tile. additionally, using a thicker grout line, off-center placement and/or cutting tiles down into smaller sizes, can also offer protection as they provide better drainage.
- verde marble, jade green, rojo alicante, cashmere grey and alpaca grey stones can be suitable options for steam showers. other stones in our lapidary collection are not suitable for steam room installations.

### ■ pools, fountains & waterlines

- not suitable for use in pools, fountains, or their water lines.

### ■ freeze/thaw rating

- not freeze/thaw rated

### ■ uv resistance

- lapidary tiles are uv resistant

### ■ fireplace surround and hearth

- can be used on fireplace surrounds and hearths
- heat resistant

### ■ backsplashes

- suitable for stove backsplashes. please consult with your installer to see if a range splash is required for your installation.
- suitable for sink backsplashes with the application of a penetrating, water-repellent sealer.

---

## GROUT

- clé recommends a  $\frac{1}{8}$ " grout joint and sanded cementitious grout on all sizes except for those that come mounted on mesh sheets.
- clé recommends using mortar and grout that comply with the ansi a118 or iso 13007 classifications suitable for your project. please consult with your installation professional to make these determinations.
- etui petit and cabochon short mosaic sheets come mounted on mesh sheets and have a fixed  $\frac{1}{16}$ " grout joint. rough cut mosaic sheet (standard joint) comes mounted on mesh sheets and will have a fixed  $\frac{1}{16}$ " grout joint.

oval petit mosaic and confetti come mounted on mesh sheets and will have a fixed  $\frac{1}{8}$ " grout joint. with these we recommend unsanded cementitious grout.

- rough cut mosaic sheet (large joint) comes mounted on mesh sheets and will have grout joints ranging from  $\frac{3}{8}$ " to  $\frac{1}{2}$ ". with these we recommend sanded cementitious grout.
- grout color selection is always up to our client and/or their design professional. however, clé is often asked for our opinion on the best grout selections for our tiles. and due to the large array of grout colors that are now available, clé would like to offer this general guideline on a grout color selection for any of your clé tiles.
  - first, have your contractor complete your tile installation, except for the grout portion.
  - next, ask your contractor to bring all grout color charts from his preferred grout manufacturer for your review.
  - lastly, choose a time of day when you are most pleased with the lighting in your space (either natural lighting, installed lighting, or a blend of both). during that lighting and time of day, select the grout color that best matches your tile selection.
- we do not generally recommend using grout of a contrasting color, as it will highlight the cracks/crazing found on the tiles, and fill in any pits, and/or chips. if you choose to use a contrasting grout (i.e. white grout with black tile) please order 20-30% overage in order to cherry-pick the tiles with the imperfections that are standard to natural stone tiles. additionally, you must make sure to apply a grout release or appropriate sealer as a pre-grout treatment to minimize the possibility of the contrasting grout curing in the cracks, pits, and/or chips.
- if your contractor is having any issues or questions regarding grout, please reach out to the grout manufacturer directly, as they are the best and fastest line of contact.

---

## SEALING, MAINTENANCE & CARE

- clé lapidary tiles are **very** sensitive to acids. please do not attempt to clean them with vinegar, lemon juice or any common household cleaners other than a gentle pH neutral cleaner.
- shower installations
  - please note that all lapidary tiles are subject to rust spots and water staining if exposed to excessive moisture.
  - to reduce the occurrence of rust spots and other water-related stains, we suggest the following maintenance plan:
    - dry off the surface after each use. we suggest using a squeegee.
    - frequent cleaning with laticrete revitalizer cleaner & protector. note: this product is mild enough that it can be used as frequently as daily.
    - spot cleaning any stains with laticrete soap scum remover or laticrete mold & mildew stain remover.
- please follow laticrete's [sealing, maintenance, and care](#) guide for more guidance on cleaning, maintaining, and caring for your tile installation.
- **if you have any questions regarding laticrete products or how to use them, please contact laticrete directly by phone: 1-800-243-4788 x 1235.**

# ADDITIONAL SPECIFICATIONS

## COLOR, TEXTURE AND SIZE VARIATION

clé lapidary collection consists of natural stone which will exhibit degrees of variation in color and shade. our tiles are cut from large blocks of stone, therefore there will be variations in color and shade across production lots or batches depending on the area of the quarry from which a particular lot was pulled. this means that your sample may not be a perfect match with your actual order, and that your add-on order may not be a perfect match to either.

the following is a guide for the different degrees of variation that we have assigned our tiles:

**color variation:** ranges from 'level 2: slight' for thassos, warm black, and white limestone, to 'level 5: extreme' for calacatta viola and iberian chocolate. all other stones are rated 'level 3: medium'.

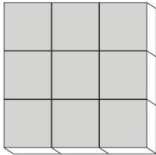
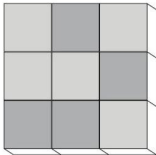
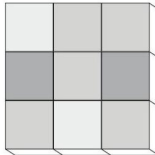
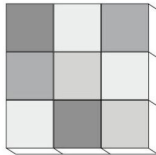
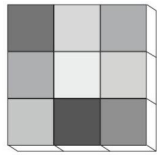
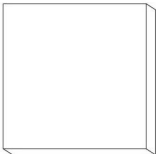
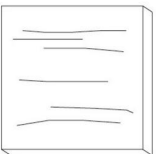
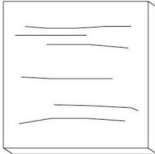
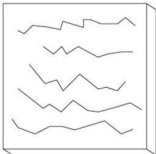
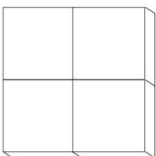
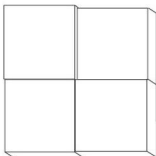
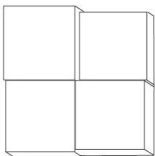
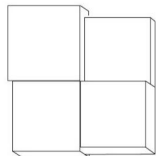

**texture variation:** beige travertine and red travertine are rated 'level 2: slight', all other stones are 'level 1: smooth' size variation is rated 'level 1: slight' for all stones.

**size variation:** rated 'level 1: slight' for all stones

CATEGORY	LEVEL 1	LEVEL 2	LEVEL 3	LEVEL 4	LEVEL 5
COLOR VARIATION	 low	 slight	 medium	 heavy	 extreme
TEXTURE VARIATION	 smooth	 slight	 medium	 heavy	n/a
SIZE VARIATION	 slight	 medium	 heavy	 extreme	n/a

## IMPERFECTIONS

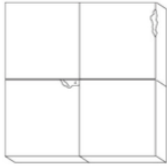
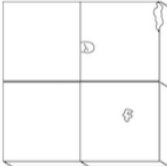
lapidary tiles are rated 'level 1: will occur' for pits/chips.

CATEGORY	LEVEL 1	LEVEL 2	LEVEL 3
PITS / CHIPS	 will occur	 prevalent	 heavy

---

## FLOOR RATING

clé lapidary tiles are rated III (can be used for light residential to light commercial foot traffic)

### **I light residential**

for residential areas with light foot traffic. examples can include bathroom, bedroom, formal dining and living rooms. please note the following:

- not suitable for shoes with hard sole profiles (cleats, stilettos, etc.)
- the floor must be kept clean from abrasive debris (gravel, mud, salt, etc.)
- immediately clean all stains (food, personal and household care products, oils, paints, chemicals etc.)

### **II heavy residential**

for residential areas with continuous foot traffic. examples can include entry, hallway, kitchen, foyer, laundry and mud rooms. please note the following:

- the floor must be kept clean from abrasive debris (sand, gravel, mud, salt, etc.)
- immediately clean all stains (food, personal and household care products, oils, paints, chemicals etc.)

### **III light commercial**

for commercial areas with light foot traffic. examples can include commercial offices, doctor's offices and boutiques. please note the following:

- the floor must be kept clean from abrasive debris (sand, gravel, mud, salt, etc.)
- immediately clean all stains (food, personal and household care products, oils, paints, chemicals etc.)

### **IV heavy commercial**

for commercial areas with continuous foot traffic. examples can include hotel lobby, retail, corridors in an office building, shopping mall and restaurant. please note the following:

- the floor must be kept clean from abrasive debris (sand, gravel, mud, salt, etc.)
- immediately clean all stains (food, personal and household care products, oils, paints, chemicals etc.)

### **V industrial**

standard industrial floor use with no extreme, heavy breakage or spillage. examples can include restaurant kitchen, bar work area, winery production, exterior hotel entry, airport, car showroom, driveway. please note the following:

- the floor must be kept clean from abrasive debris (sand, gravel, mud, salt, etc.)
- immediately clean all stains (food, personal and household care products, oils, paints, chemicals etc.)

---

## PRODUCT DESCRIPTION

honed stones.

---

## PRODUCT COMPONENTS

natural stone.

---

## DIMENSIONS

SHAPE	PIECE DIMENSIONS	WEIGHT	SHEET DIMENSIONS	PIECES PER SHEET
CABOCHON GRAND	3 cm x 59.7 cm x 1.69 cm (1¼" x 23½" x ⅝")	0.66 kg per tile (1.5 lbs)		
CABOCHON SHORT MOSAIC SHEET	3 cm x 15.2 cm x 1.6 cm (1¼" x 6 x ⅝")	0.18 kg per tile (0.39 lb)	30.5 cm x 31.5 cm (12" x 12⅜" x ⅝")	20
ETUI GRAND	3 cm x 59.7 cm x 1.7 cm (1¼" x 23½" x ⅝")	0.65 kg per tile (1.4 lbs)		
ETUI PETIT MOSAIC SHEET	3 cm x 15.2 cm x 1.3 cm (1¼" x 6 x ½")	0.12 kg per tile (0.28 lb)	30.5 cm x 31.5 cm (12" x 12⅜" x ½")	20
OVAL LONG	6 cm x 21.6 cm x 0.95 cm (2⅜" x 8½" x ⅜")	0.3 kg per tile (0.7lbs)		
OVAL PETIT MOSAIC SHEET	3.5 cm x 15.2 cm x 0.95 cm (1⅜" x 6" x ⅜")	0.13 kg per tile (0.28 lb)	28.6 cm x 31.4 cm (11¼" x 12⅜" x ⅜")	16
ROUGH CUTS SHEET (LARGE JOINT)	individual tiles range from: 2 - 4 cm x 5 cm x 0.95 cm (¾" - 1⅝" x 2" x ⅜") grout joints range from: ⅜"-⅝"	0.04 kg per tile (0.08 lb)	30.5 cm x 31.1 cm (12" x 12¼" x ⅜")	35
ROUGH CUTS SHEET (STANDARD JOINT)	individual tiles range from 2.5 - 4.5 cm x 5.5 cm x 0.95 cm (1" - 1¾" x 2⅛" x ⅜") grout joints: ¼"	0.4 kg per tile (0.08 lbs)	28.5 cm x 31.5 cm (11¼" x 12¼" x ⅜")	40

\* please note all dimensions are nominal and can vary +/- ⅛".

---

## AVERAGE COEFFICIENT OF FRICTION (DCOF ACUTEST)

Wet Exterior ( Wet DCOF >0.55)	Wet Interior (Wet DCOF >0.42)	Dry Interior (Dry DCOF >0.42)
alpaca grey, beige travertine, calacatta gold, calacatta viola, iberian chocolate, pink/grey, red travertine, rojo alicante, warm black, white limestone	carrara, cashmere grey, galician green, Jade green, rosso italiano, thassos, verde marble	all stones

please note, etui petit, cabochon short, etui grand, and cabochon grand are strictly wall tiles.

\*application of an anti-slip sealer or treatment can help increase slip resistance.

\*DCOF is only one factor and should be considered together with levelness of surface to be tiled, type of use, expected traffic, contaminants, maintenance, and wear when choosing a tile for your project

per ANSI A326.3 standards:

- interior floors meant to be walked on *when dry* should have a dry DCOF of at least 0.42,
- interior floors intended to be walked on *when wet* should have a wet DCOF of at least 0.42,
- exterior floors intended to be walked on *when wet* should have a wet DCOF of at least 0.55

---

## FREEZE/THAW RESISTANCE (ASTM C1026)

clé lapidary tiles are not freeze/thaw resistant.

---

## WATER ABSORPTION (ASTM C97)

IMPERVIOUS ≤ 0.50%	VITREOUS 0.50% < 3.0%	SEMI-VITREOUS 3.0% < 7.0%
alpaca grey, calacatta gold, calacatta viola, carrara, cashmere grey, jade green, galician green pink/grey, rojo alicante, verde marble	beige travertine, iberian chocolate, red travertine, rosso italiano, warm black	thassos, white limestone

---

## ACID RESISTANCE

clé lapidary tiles are not resistant to acids and only mild, pH neutral cleaners should be used.

---

## LEED CREDITS

the product is an inherently non-emitting source of VOCs (stone, ceramic, metals, powder-coated metals, plated or anodized metal, glass, cement, clay brick, and unfinished or untreated solid wood) and has no integral organic-based surface coatings, binders, or sealants.

natural stone tiles are considered 'inherently non-emitting sources' under the Low-emitting Materials Credit of LEEDv4/v4.1. **this is the only credit for our lapidary tiles that is eligible to be used toward LEED.**

'inherently non-emitting' means that these tile types have been shown to not contribute emissions to indoor environments and are therefore exempt from demonstrating compliance with CDPH v1.1-2010 or CDPH v1.2-2017.

use of these tiles as wall or flooring materials should be entered in the LEED v4.1 low-emitting materials calculator and identified as 'inherently non-emitting' in the products tab (column I).

disclosures for MR credit material ingredient disclosures under LEED v4/v4.1 are not available at this time. we are exploring our disclosure options and have not established a timeline for completion.

disclosures for MR credit environmental product declarations under LEED v4/4.1 are not available at this time. we are exploring our disclosure options and have not established a timeline for completion.

contribution to MR credit material sourcing under LEED v4/v4.1 does not apply as there is no recycled content, no bio-based materials, no wood, no reused products included in our tile at this time. extended producer responsibility programs are highly difficult to manage given the nature of end-of-use tile removal methods. *tile can last hundreds of years but fashions often change, which is the dominant reason for its removal. we work hard to ensure our stone tiles can withstand the test of time while remaining timeless.*

---

## **RECYCLED CONTENT**

there is no recycled content in our clé lapidary tiles. see material sourcing disclosure above.

---

## **PERCENTAGE OF PRE-CONSUMER AND/OR POST-CONSUMER MATERIALS**

there is no pre-consumer or post-consumer material content in our tiles.. see material sourcing disclosure above.

---

## **FIRE RATING**

typically, natural stone tile does not need to have fire rating testing performed. it is our understanding from tcna that the explanation that natural stone is inorganic, inert, and typically free of materials that could burn or produce smoke is generally enough to satisfy a specifier and that testing is not necessary.

natural stone tile falls under the description, “because stone tile is non-flammable and does not produce smoke in a fire, it inherently meets the flame spread and smoke development requirements of section 803 of the international building code (IBC) for interior wall and ceiling materials.”