

NO	P/N	Tooling	Working process Description	REVISIONS			
1	SQZ-10090			SYM.	BY.	REVISIONS	DATE
				A.			

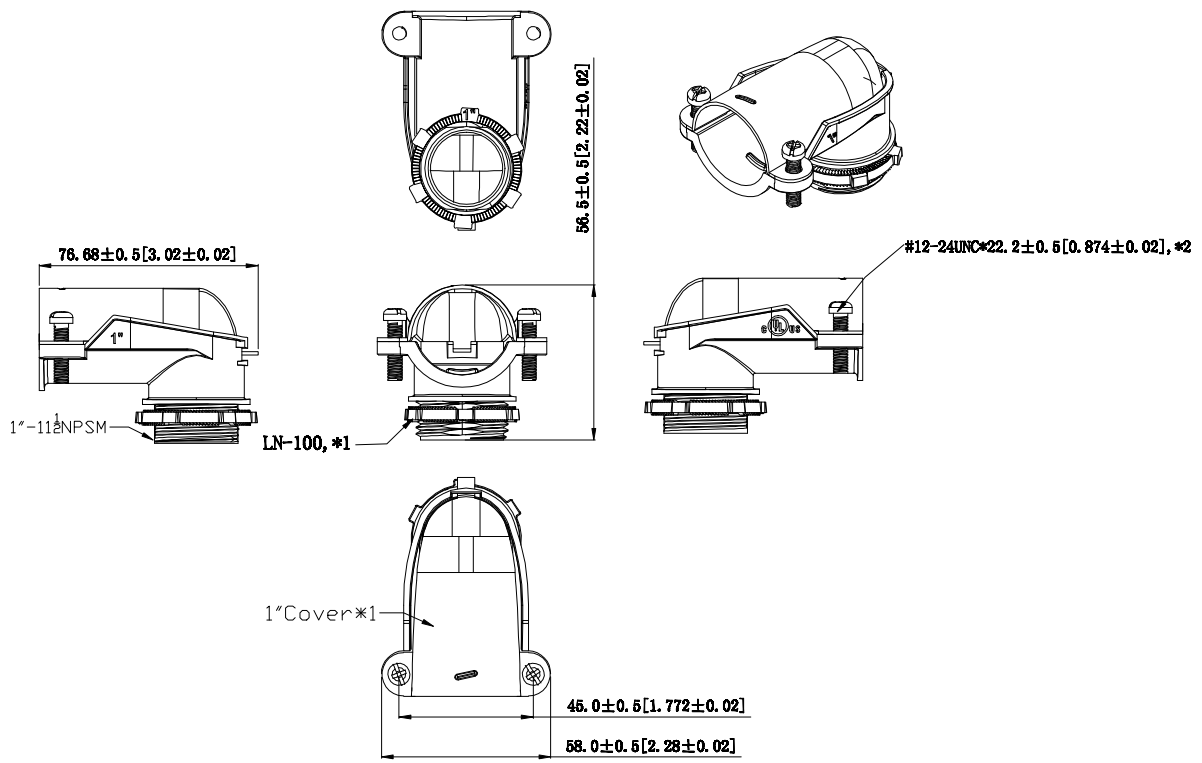

NOTES:
 1.All dimensions in millimeters and [inches];
 2.Free of sharp edge and burrs.max burr 0.5[0.0196].
 3.Material: G60 steel ; thickness: 2.0mm[0.078].

THIRD ANGLE PROJECTION 	UNLESS OTHERWISE SPECIFIED DIMENSIONS ARE IN MILLIMETERS DECIMALS ARE: X.X ± 0.10 [± 0.004] X.XX ± 0.05 [± 0.002] X.XXX ± 0.01 [± 0.0005]	NAME DATE	GARVIN INDUSTRIES	
	MATERIAL G60 STEEL	DRAWN CHECKED APPROVED (P) APPROVED (Customer)	2014. 01. 08	TITLE ELECTRICAL TRADE WASHERS
FINISH 2000V SPARK PROOF STANDARD PER ANSI Y46.1-1994	THIS DOCUMENT IS THE PROPERTY OF GARVIN INDUSTRIES AND IS LOANED TO YOU FOR YOUR INFORMATION ONLY. IT IS NOT TO BE REPRODUCED OR TRANSMITTED IN ANY FORM OR BY ANY MEANS, ELECTRONIC OR MECHANICAL, INCLUDING PHOTOCOPYING, RECORDING, OR BY ANY INFORMATION STORAGE AND RETRIEVAL SYSTEM. ALL RIGHTS RESERVED. GARVIN INDUSTRIES, GARVIN, THE GARVIN LOGO AND GARVIN TRADE MARK ARE REGISTERED TRADEMARKS OF GARVIN INDUSTRIES. GARVIN INDUSTRIES IS NOT RESPONSIBLE FOR THE CONTENTS OF THIS DOCUMENT.	SIZE A4	DWG NO. SQZ-10090	REV
	SCALE: 1:1	PART DATE	EXPERIENCES	SHEET 1 OF 1