

LIMITED WARRANTY

PERFORMANCE TOOL® extends only the following warranties, and only to original retail purchasers. These warranties give specific legal rights. Except where prohibited by local law, the law of the State of Washington governs all warranties and all exclusions and limitations of warranties and remedies. There may be other rights which vary from state to state.

PERFORMANCE TOOL® warrants the product to be free from defects in materials and workmanship under normal use and service. A defective product may be returned for a free replacement within 90 days from the date of purchase, provided that product is returned to place of purchase immediately after discovery of defect. After 90 days and up to one year from date of purchase, PERFORMANCE TOOL® will replace at no charge any parts which our examination shall disclose to be defective and under warranty. These warranties shall be valid only when a sales receipt showing the date of purchase accompanies the defective product or defective part (s) being returned. For part (s) after 90 days, please remit your request, postage prepaid to:

PERFORMANCE TOOL, P.O. Box 88259 Tukwila, WA 98138

These warranties exclude blades, bits, punches, dies, bulbs, fuses, hoses, and other consumables which must be replaced under normal use and service. These warranties shall not apply to any product or part which is used for a purpose for which it is not designed, or which has been repaired or altered in any way so as to affect adversely its performance or reliability, nor shall these warranties apply to any product or part which has been subject to misuse, neglect, accident or wear and tear incident to normal use and service.

PERFORMANCE TOOL® does not authorize any other person to make any warranty or to assume any liability in connection with its products.

Except for warranties of title and the limited express warranties set forth above, PERFORMANCE TOOL® makes no express or implied warranties of any kind with respect to its products. In particular, PERFORMANCE TOOL® makes no implied warranty of merchantability and no implied warranty of fitness for any particular purpose, except that for goods purchased primarily for personal, family or household use and not for commercial or business use, PERFORMANCE TOOL® makes an implied warranty of merchantability (and, if otherwise applicable, an implied warranty of fitness for a particular purpose), but only for the particular qualities or characteristics, and for the duration, expressly warranted above.

The laws on limitation of implied warranties may differ from state to state, so the above limitations may not apply in all cases.

PERFORMANCE TOOL® shall not be liable for consequential, incidental or special damages resulting from or in any manner related to any product, or to the design, use, or any inability to use the product. The sole and exclusive remedy for a defective product or part shall be the repair, or replacement thereof as provided above. The laws on limitation of remedies or on consequential, incidental or special damages may vary from state to state, so the above limitations may not apply in all cases.

© Copyright 2017 WILMAR CORPORATION, P.O. Box 88259 Tukwila, WA 98138

2.5 TON GARAGE JACK

Stock Number W1640

OWNER'S MANUAL



Performance Tool®

▲ WARNING!

It is the owner and/or operators' responsibility to study all WARNINGS, operating, and maintenance instructions contained on the product label and instruction manual prior to operation of this tool. The owner/operator shall retain product instructions for future reference.

The owner and/or operator are responsible for maintenance, maintaining all decals or warning labels and while in use, maintaining the unit in good working order. If the owner and/or operator are not fluent in English, the product warnings and instructions shall be read and discussed in the operators' native language by the purchaser/owner or his designee. Make sure that the operator comprehends its contents. Safety information shall be emphasized and understood prior to usage. The tool shall be inspected per the operating instructions.

Protect yourself and others by observing all safety information.

Failure to comply with instructions could result in personal injury and/or property damage!

If you encounter any problems or difficulties, please contact our customer service department at: 1-800-426-1262 between 6:30 a.m. and 4:30 p.m. Pacific time.

PT

Performance Tool®

Please read these instructions carefully and retain them for future use.

On occasion, after printing of our literature is completed, our manufacturers may make changes and/or modifications to merchandise which will not be reflected in this manual. Although we strive to maintain complete and accurate information, it is possible in some instances, that the product may differ slightly from printed specifications. Illustrations are intended for reference only. Actual merchandise may vary. Wilmar is not responsible for typographical errors.

RAM REPLACEMENT PARTS LIST

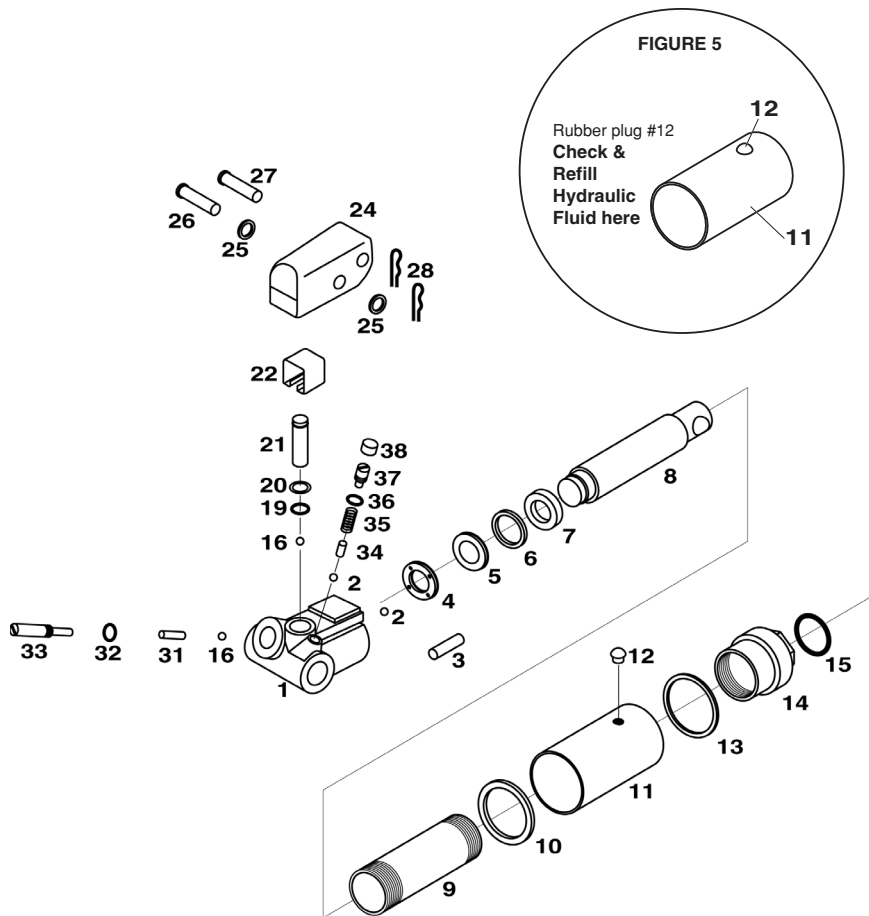

Ram Assembly Parts List

#	Description	Qty.	#	Description	Qty.	#	Description	Qty.
1	Hydraulic Unit Body	1	12	Oil Fill Plug	1	26	Piston Pin	1
2	3/16" Steel Ball	2	13	Fiber Washer (A)	1	27	Connecting Pin	1
3	Filter Body Screen	1	14	Top Nut	1	28	Retaining Pin	2
4	Copper Washer	1	15	Top Nut O-Ring	1	31	Release Valve Spacer	1
5	Pump Cylinder O-Ring	1	16	1/4" Steel Ball	2	32	Release Valve O-Ring	1
6	Back Up Ring	1	19	Pump Cylinder O-Ring	1	33	Release Valve	1
7	Ram Collar	1	20	Back Up Ring	1	34	Spring Guide	1
8	Ram	1	21	Pump Piston	1	35	Overload Valve Spring	1
9	Cylinder	1	22	Piston Clamp	1	36	O-Ring	1
10	Fiber Washer (B)	1	24	Handle Sleeve	1	37	Adjusting Screw	1
11	Oil Chamber	1	25	Piston Washer	2	38	Cap	1

OPERATION

Before using your jack:

1. Turn release valve counter-clockwise to open. Pump jack handle about 6 full strokes to assure complete distribution of hydraulic fluid. (See Figure 1)

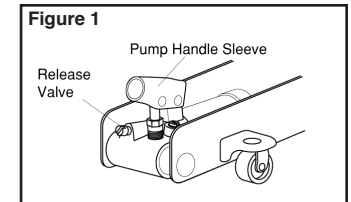

To raise:

Place pump handle over release valve and turn clockwise to close. Make certain that load is on center of saddle. Insert handle into handle sleeve and pump to raise load to desired height. Transfer load to jack stands or other appropriate supports before working under load. (See figure 2)

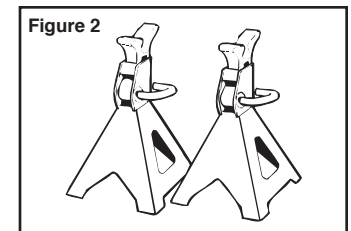

To lower:

Raise load enough to remove jack stands. **Slowly** turn release valve counter-clockwise just enough to allow controlled descent. (Never turn counter-clockwise more than 3 full turns)

CARE & MAINTENANCE

1. When jack is not in use, lifting arm and handle sleeve should be in fully down position to keep their machined surfaces free from corrosion.
2. Keep jack clean and well lubricated at points illustrated in figure 3.
3. For best results, use only hydraulic fluid with a rating of SAE 10 for refills. Check fluid level with jack in fully down position. Fluid level should be up to bottom of oil fill plug. (See figure 5)
4. Regularly check for loose, worn or damaged parts and repair or replace as necessary.
5. Replace worn or damaged parts with Performance Tool replacement parts. Be sure that only qualified personnel perform repairs.

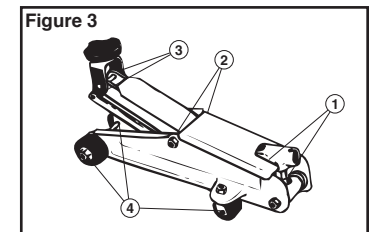

REPLACEMENT PARTS LIST

Figure 4

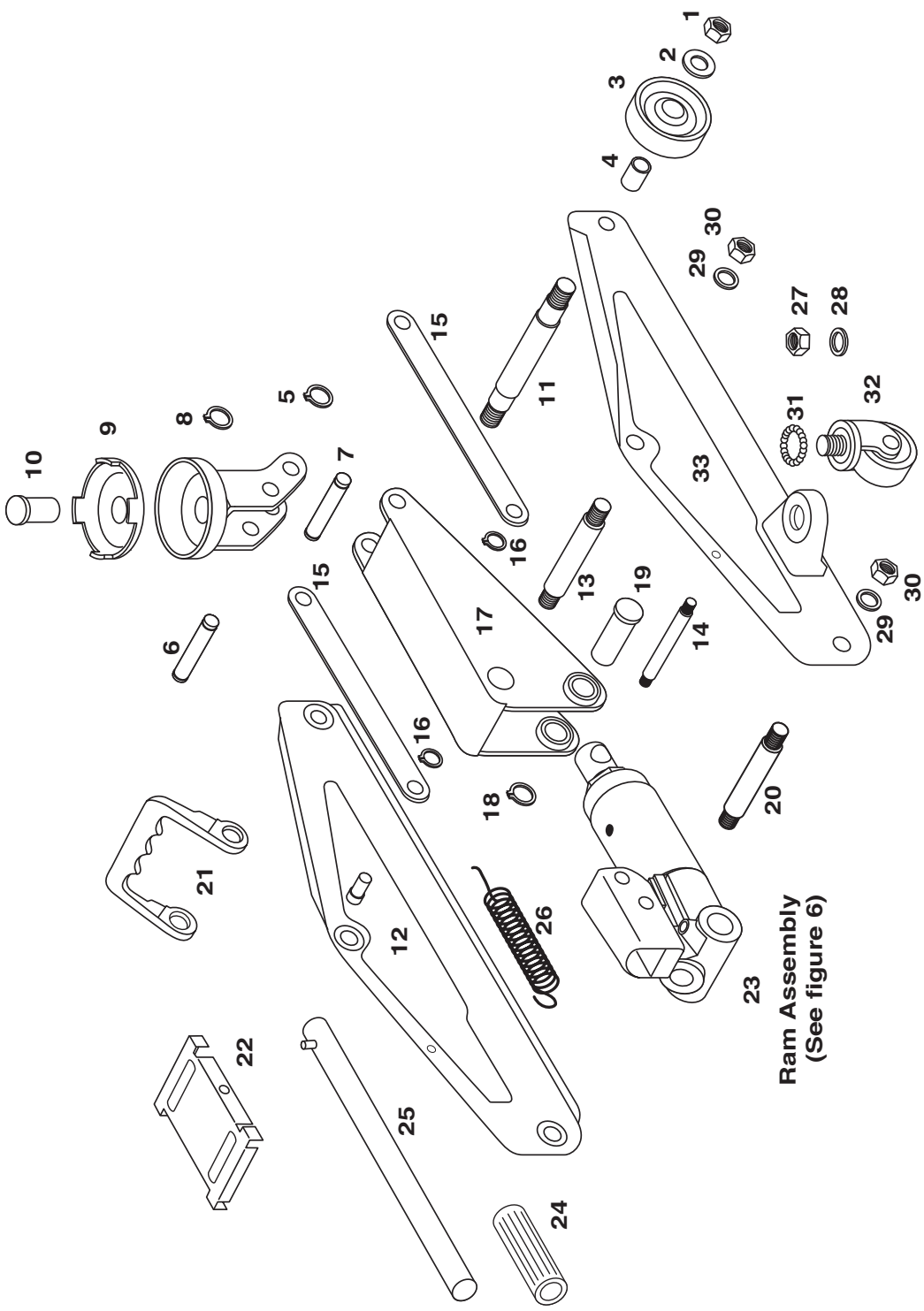

Parts List

#	Description	Qty.	#	Description	Qty.	#	Description	Qty.
01	Nut M12	2	12	Frame Unit - Left	1	23	Ram	1
02	Washer 12	2	13	Middle Shaft	1	24	Handle Cover	1
03	Front Wheel	2	14	Lift Arm Axle	1	25	Handle	1
04	Axle Bushing	2	15	Long Linker	2	26	Spring	1
05	Snap Ring "C" 13	2	16	Snap Ring "C" 10	2	27	Nut M8	4
06	Saddle Shaft	1	17	Lift Arm	1	28	Washer 8	4
07	Saddl Bracket	1	18	Snap Ring "C" 19	2	29	Washer 12	6
08	Snap Ring "C" 13	1	19	Shaft	1	30	Nut M12	4
09	Saddle	1	20	Piston Rod Shaft	1	31	Ball Bracket	2
10	Saddle Pin	1	21	Carry Handle	1	32	Caster Bracket	2
11	Front Wheel Axle	1	22	Inspection Plate	1	33	Frame Unit - Right	1

SPECIFICATIONS

Capacity: 5,000 lbs.
 Low Height: 5"
 Max. Height: 15-1/2"
 Lift Range: 10-1/2"

Specifications are subject to
 change without notice

IMPORTANT SAFETY INFORMATION

Read these safety warnings before operation.

WARNING!

Failure to heed these warnings may result in loss of load, damage to jack, and/or jack failure resulting in personal injury or property damage.

WARNING!

This is a lifting device only. Do not move load while it is on the jack. Load must be supported immediately by Jack Stands or other appropriate means.

Do not overload jack beyond rated capacity. Overloading can cause damage to or failure of the jack.

REFER TO YOUR VEHICLE OWNERS MANUAL FOR PROPER JACKING PROCEDURES. Lift only on areas of the vehicle as specified by the vehicle manufacturer.

This jack is designed for use only on hard level surfaces capable of sustaining the load. Use of jack on other than hard level surfaces can result in jack instability and possible loss of load.

Be sure all personnel are clear of load before lowering load.

Ensure that no personnel pass underneath load until load is securely supported by jack stands.

TROUBLESHOOTING

Your Performance Tool hydraulic jack was constructed with quality materials and workmanship and will give you many years of trouble free use when cared for as described in the "Care & Maintenance" section on page 3. However, as with any mechanical device, periodic adjustments are necessary to maintain a peak level of performance. Should your jack be displaying any of the following symptoms, the simple procedures shown below will correct the problem.

WARNING - Remove jack from service before making adjustments

Will not lift load	●	●	●
Will not hold load			●
Will not lift to full height	●	●	
Pump feels "spongy" under load	●	●	
Handle raises under load			●
Handle lowers under load			●
	Power unit may be low on fluid. With jack on level surface and in down position, remove filler plug and add clean hydraulic jack fluid to level of filler hole.	Power unit may be airborne. Open the release valve a minimum of 2 full turns. Pump the handle a minimum of 20 full strokes to purge air from the system.	Valves may not be closing completely. To seat valves: a.) Close release valve. b.) With jack in fully lowered position, manually raise lifting arm as high as possible. c.) Open release valve and allow jack to descend to lowered position.

NOTE:

Problems listed above with more than one solution may have a combination of causes. Please be sure that all solutions listed for each problem have been checked to eliminate possibility of further trouble. Sometimes solutions may need to be repeated for best results.