



Project \_\_\_\_\_  
 Item # \_\_\_\_\_  
 Quantity \_\_\_\_\_

# SPECTRUM

## Commercial Electric Countertop Thermal Circulator

Models: ESVC-28D, ESVC-28D-CAN, ESVC-28-CE

Get sous vide cooking with the SPECTRUM THERMAL CIRCULATOR. With precise temperature control and by reducing heat fluctuations, food retains moisture, nutrition, and flavor for perfect results every time.

### Standard Features

- ◆ All stainless steel construction
- ◆ Easy to use solid state digital control panel
- ◆ Wire clip on side conveniently holds lid when open
- ◆ Built-in drain valve for easy water removal
- ◆ Includes sectioned removable lifting rack to cook multiple vacuum-sealed portions
- ◆ 5ft (1.5m) power cord
- ◆ Precise temperature accuracy: +1°F (0.5°C)
- ◆ Maximum volume capacity: 7.4 gallons (28L)
- ◆ Temperature range: 41°F to 210°F (5°-99°C)
- ◆ Timer setting range: 5 minutes – 99 hours
- ◆ LED display: Optional °F / °C, with last temperature and time memory when turned on
- ◆ One year parts and labor warranty



ESV-BH



ESV-IB

### Options & Accessories

ESV-BH	Stainless Steel 3-Ring Bag Holder Stand
EVPB-0610	Vacuum Sealer Bags, 6" x 8"
EVPB-0812	Vacuum Sealer Bags, 8" x 12"
ESV-IB	Sous Vide Insulation Balls
EVPM-12	Chamber Vacuum Packaging Machine
NSP-10W	10" High Heat Nylon Mixing Paddle (400°F & BPA Free)
NS-12	12" High Heat Nylon Spoon (400°F & BPA Free)

**For California Customers**  
**WARNING:** Cancer and Reproductive Harm - [www.P65Warnings.ca.gov](http://www.P65Warnings.ca.gov)

Winco®

[www.wincous.com](http://www.wincous.com)

**New Jersey Headquarters & Distribution Center**  
 65 Industrial Road, Lodi, NJ 07644  
 Phone: 1-888-946-2682 | Fax: 1-973-916-9959

**Florida Showroom & Distribution Center**  
 10800 NW 103rd St. Bldg 22, Ste 11, Miami, FL 33178  
 Phone: 1-888-946-2682 | Fax: 1-973-916-9959

**Nevada Distribution Center**  
 3777 Marion Drive, Las Vegas, NV 89115  
 Phone: 1-888-946-2682 | Fax: 1-973-916-9959



**Commercial Electric  
Countertop Thermal Circulator**  
Models: ESVC-28D, ESVC-28D-CAN, ESVC-28-CE

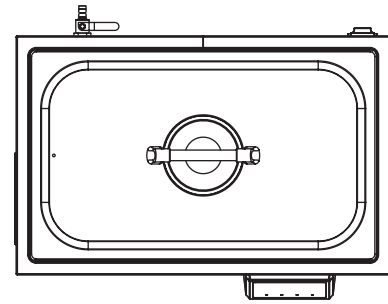

TOP VIEW

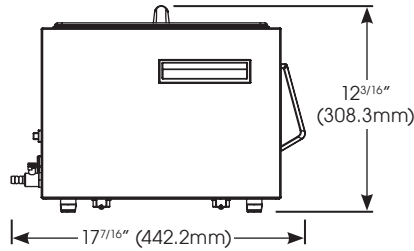

SIDE VIEW

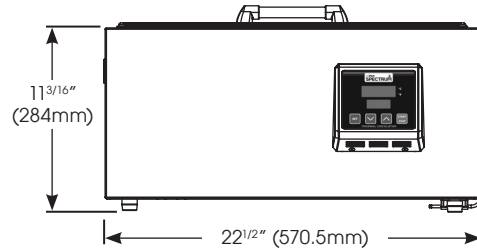

FRONT VIEW

**Specifications**

MODEL	OVERALL DIMENSIONS			VOLTS	HZ	WATTS	AMPS	PLUG	SHIP WEIGHT
	LENGTH	DEPTH	HEIGHT						
ESVC-28D	22-1/2" (570.5mm)	17-7/16" (442.2mm)	12-3/16" (308.3mm)	120	60	1800	15	NEMA 5-15P	18.74 lbs (8.5 kgs)
ESVC-28D-CAN				120	60	1800	15	NEMA-5-20P	
ESVC-28D-CE				220	50	1800	8.18	VDE	

**Cord Location**

On back right side

**Plug Configuration**

NEMA 5-15P

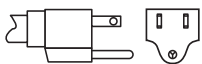

ESVC-28D

NEMA 5-20P

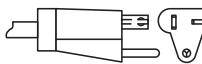

ESVC-28D-CAN

VDE

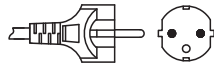

ESVC-28D-CE

**Product Specs**

**Spectrum Commercial Electric Thermal Circulator**

The Commercial Electric Countertop Thermal Circulator models ESVC-28D, ESVC-28D-CAN, and ESVC-28D-CE as manufactured by Winco®, Lodi, NJ 07644.

The Commercial Electric Thermal Circulator models ESVC-28D and ESVC-28D-CAN shall be rated at 1800 Watts, 120V-60Hz. ESVC-28D-CE shall be rated at 1800 Watts, 220V-50Hz.

All models shall be used with a maximum volume capacity of 7.4 gallons (28L). Wire clip on the side conveniently holds lid when open. Built-in faucet and drain allow easy water removal. Sectioned tray included to cook multiple vacuum-sealed portions. Controls and display have precise temperature accuracy of +1°F (0.5°C). Temperature range of 41°F to 210°F (5°C to 99°C). Timer setting range of 5 minutes to 99 hours, and LED display with optional °F / °C, with last temperature and time memory when turned on.

The optional stainless steel 3-Ring Bag Holder Stand (ESV-BH) conveniently holds various sizes of vacuum-packing bags open for easy filling.

The optional Insulation Balls (ESV-IB) add insulation to any open cooking bath, effectively reducing heat loss and evaporation.

ETL listed for safety (Canada & US) and sanitation for ESVC-28D and ESVC-28D-CAN. CE certification for ESVC-28DCE.

Warranty consists of one year parts and labor.

Winco®

www.winco.us.com

**New Jersey Headquarters & Distribution Center**  
65 Industrial Road, Lodi, NJ 07644  
Phone: 1-888-946-2682 | Fax: 1-973-916-9959

**Florida Showroom & Distribution Center**  
10800 NW 103rd St, Bldg 22, Ste 11, Miami, FL 33178  
Phone: 1-888-946-2682 | Fax: 1-973-916-9959

**Nevada Distribution Center**  
3777 Marion Drive, Las Vegas, NV 89115  
Phone: 1-888-946-2682 | Fax: 1-973-916-9959