

Assembly Guide

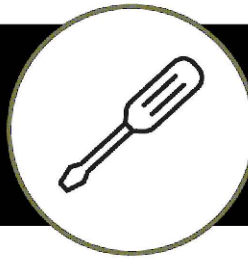

Bush
FURNITURE



If you're having any difficulty during assembly of this product, don't hesitate to call us at 1-800-950-4782.

Our customer service experts are trained to provide step-by-step instruction and can easily replace any missing or damaged parts.

Representatives are available Monday-Friday from 8:30 a.m. to 7:30 p.m. (ET)

Medicine Cabinet with Mirror

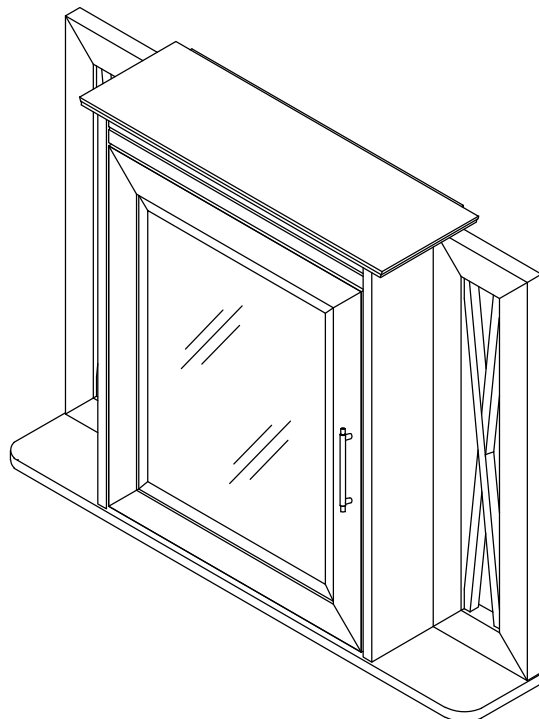

Lot Code #

Part Number A217161

Keep manual for future reference.

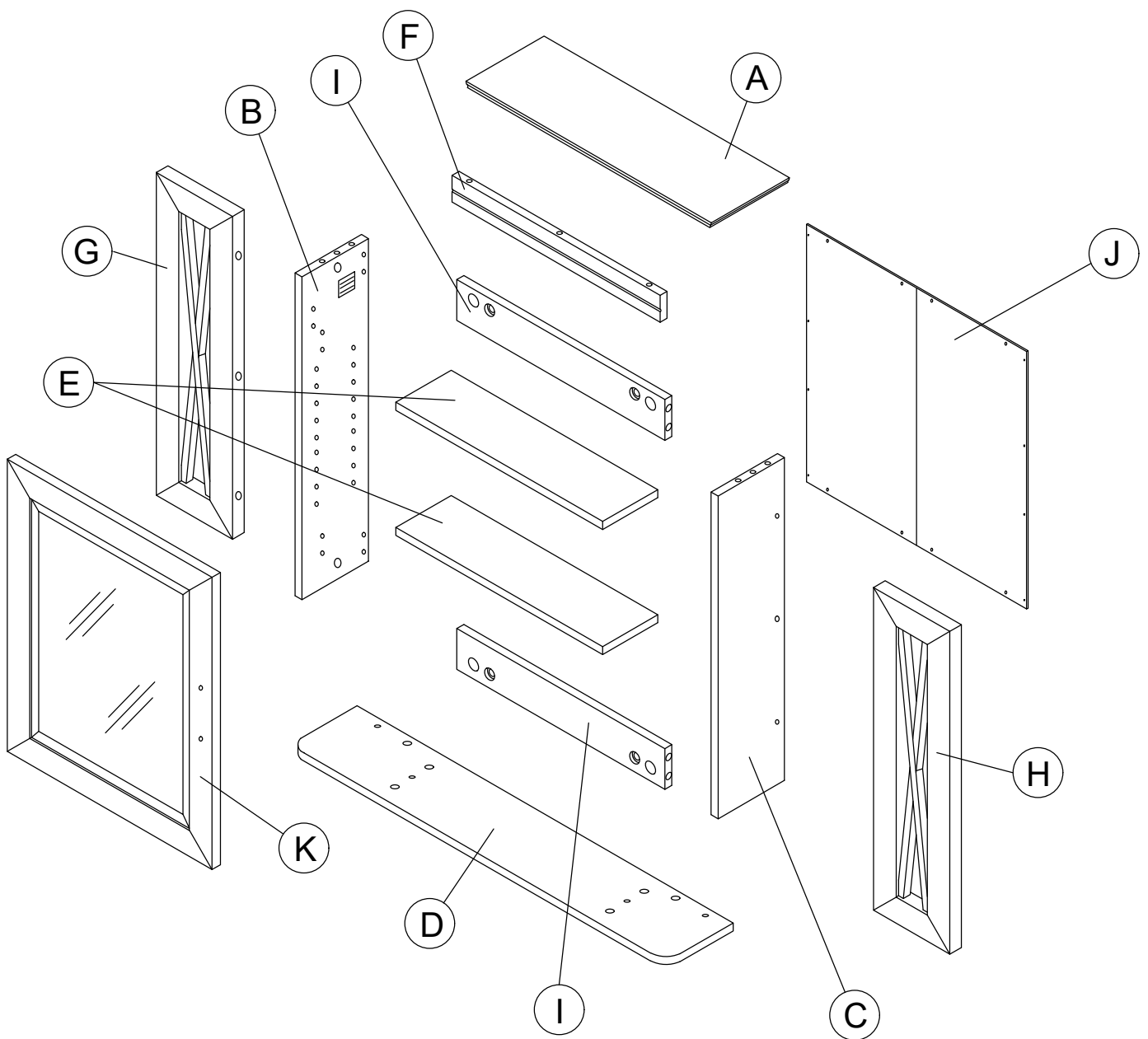
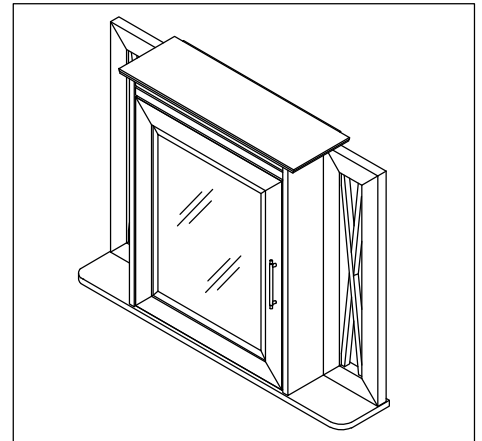

Have an assembly question or need a replacement part? Just call
1-800-950-4782, we are here to help.

Fasteners are shown actual size.

H72988

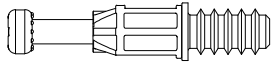

[16]

KD Bolt

H181468

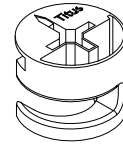

[16]

KD Cam

H38169



[17]

Wood Dowel
8 x 30mm

H158933

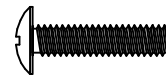

[2]

#8 x 3/4"

H153242

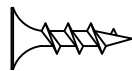

[4]

#8 x 5/8"

H124395



[9]

#6 x 1/2"

H34174



[8]

3 x 3/4"

Have an assembly question or need a replacement part? Just call
1-800-950-4782, we are here to help.

Hardware not to scale.

H200012

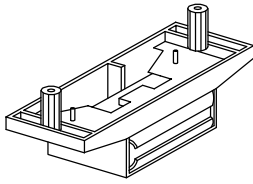

Magnetic Top

[1]

H217164

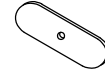

Strike Plate

[1]

H180971

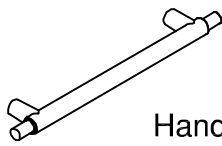

Handle

[1]

H23604

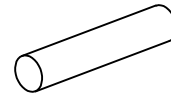

Shelf Pin
1" x 3/16"

[8]

H170611

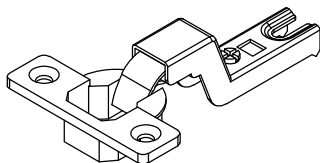

Hinge

[2]



Cover Cap

[10]

H170612

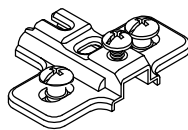

Mounting Plate

[2]

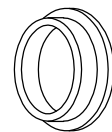

Hole Plug

[6]

Have an assembly question or need a replacement part? Just call
1-800-950-4782, we are here to help.

Hardware not to scale.

WALL ATTACHMENT HARDWARE

H217165

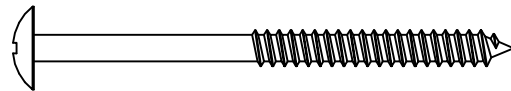

[4]

10 X 2.5 "

H107572

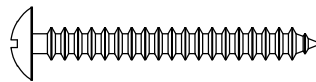

[4]

#8x1-1/2"

H200009

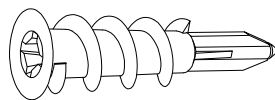

[4]

Wall Anchor

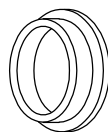

[4]

Hole Plug

Have an assembly question or need a replacement part? Just call
1-800-950-4782, we are here to help.

STEP 1

Prepare Panels

A217161

H38169

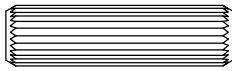

[5]

Wood Dowel
8 x 30mm

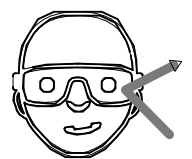
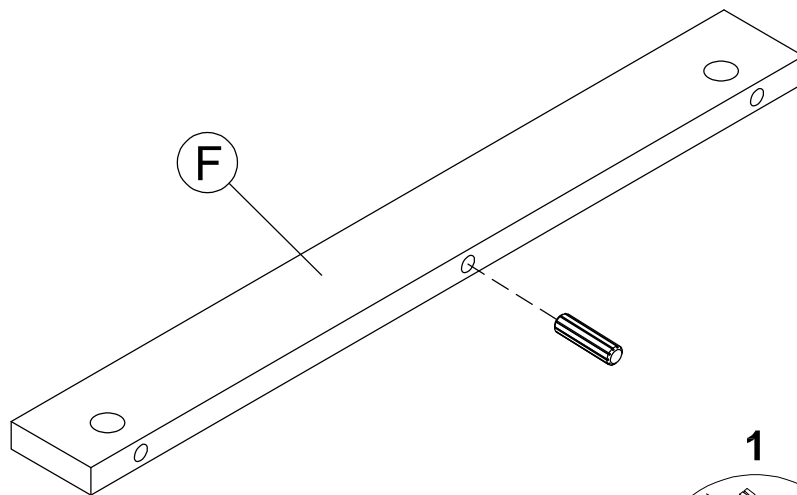
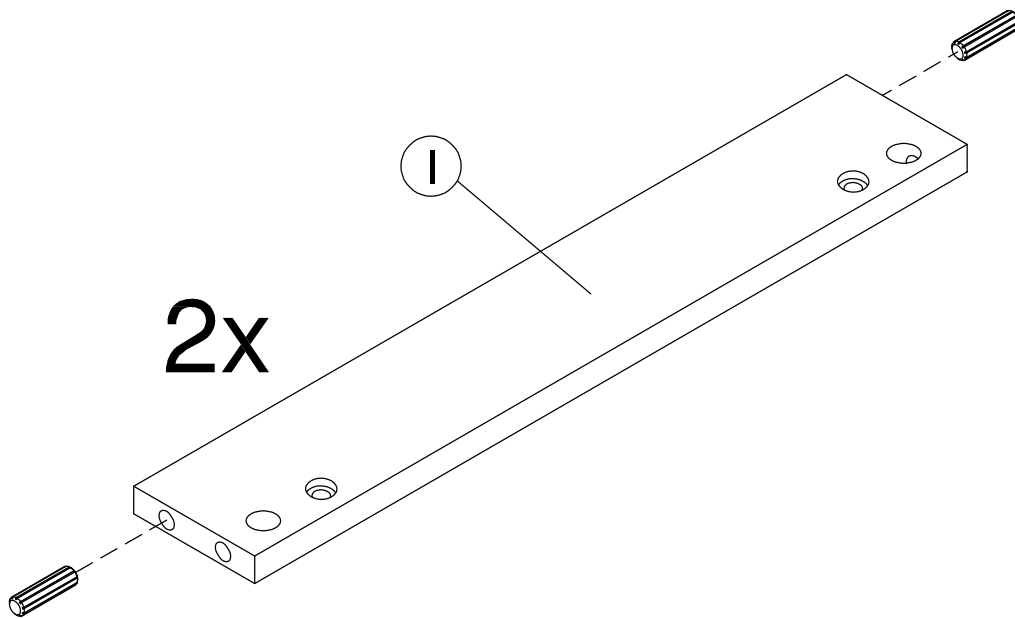

Safety glasses
Gafas de seguridad
Lunettes de protection

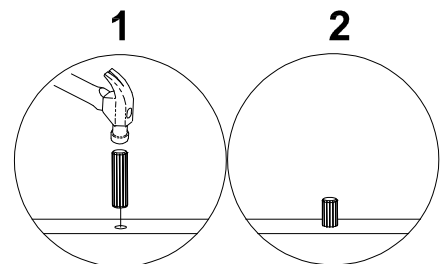

Have an assembly question or need a replacement part? Just call
1-800-950-4782, we are here to help.

STEP 2

Prepare Panels

A217161

H72988

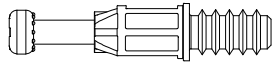

[8]

KD Bolt

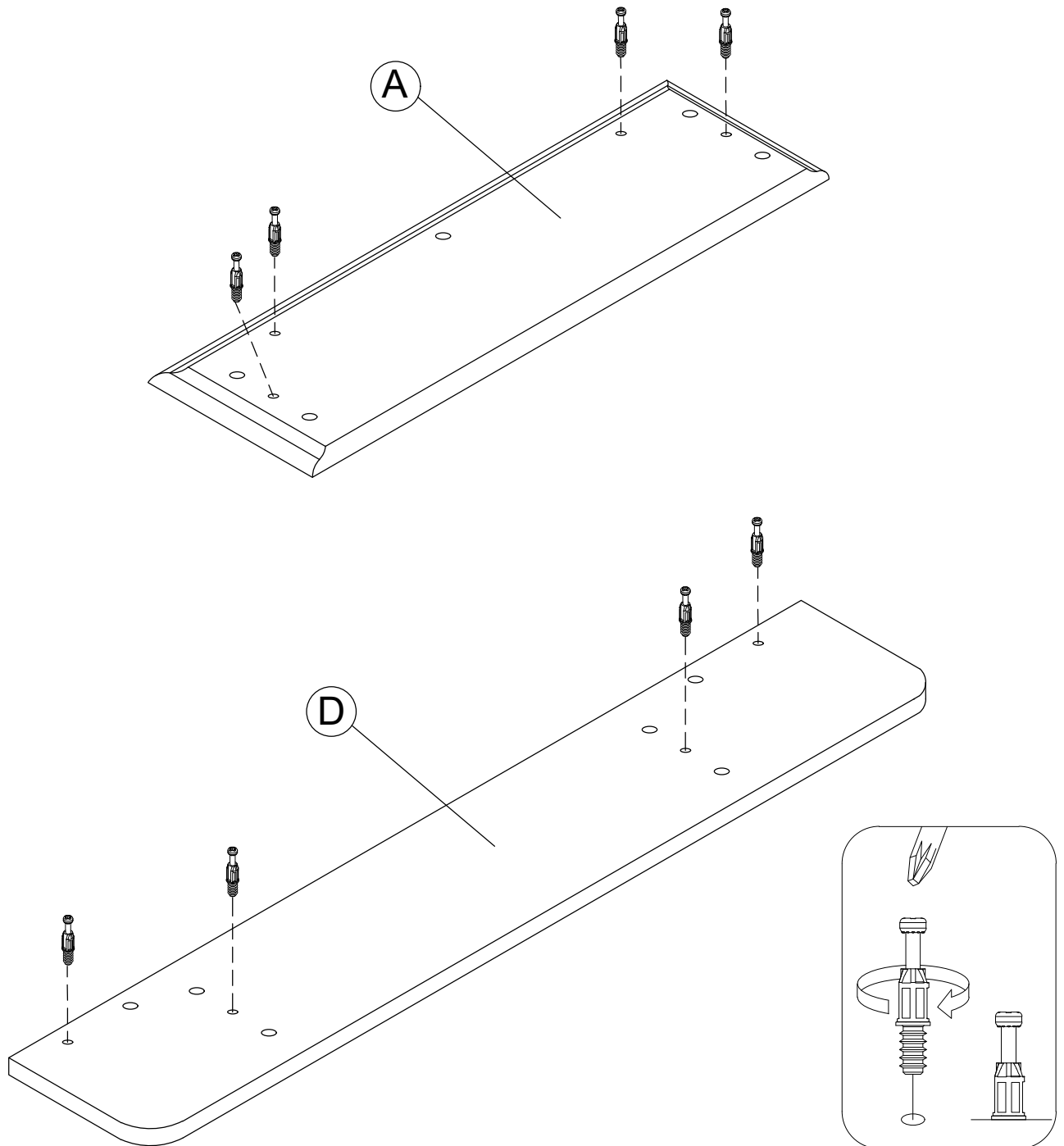

Have an assembly question or need a replacement part? Just call
1-800-950-4782, we are here to help.

STEP 3

Assemble Panels

A217161

Scan QR Code to Watch Video on:



How to Tighten KD Cams

H181468

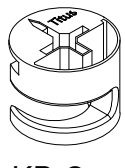

KD Cam

[2]

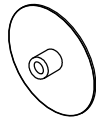

Cover Cap

[2]

1

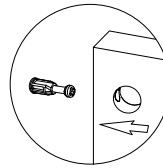

2

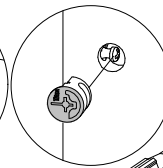

3

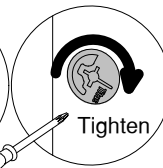

4

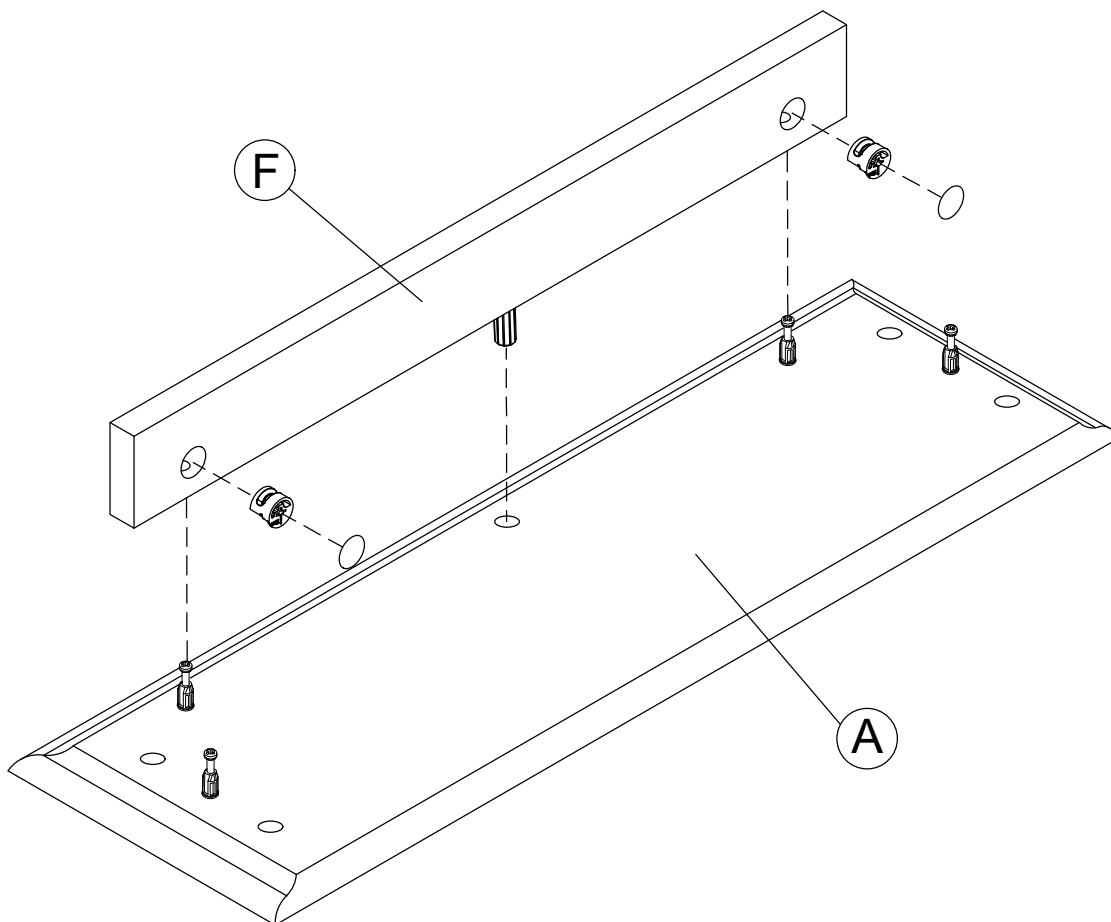
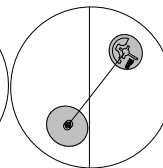

Have an assembly question or need a replacement part? Just call **1-800-950-4782**, we are here to help.

H38169

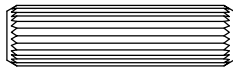

[4]

Wood Dowel
8 x 30mm

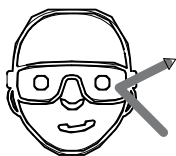
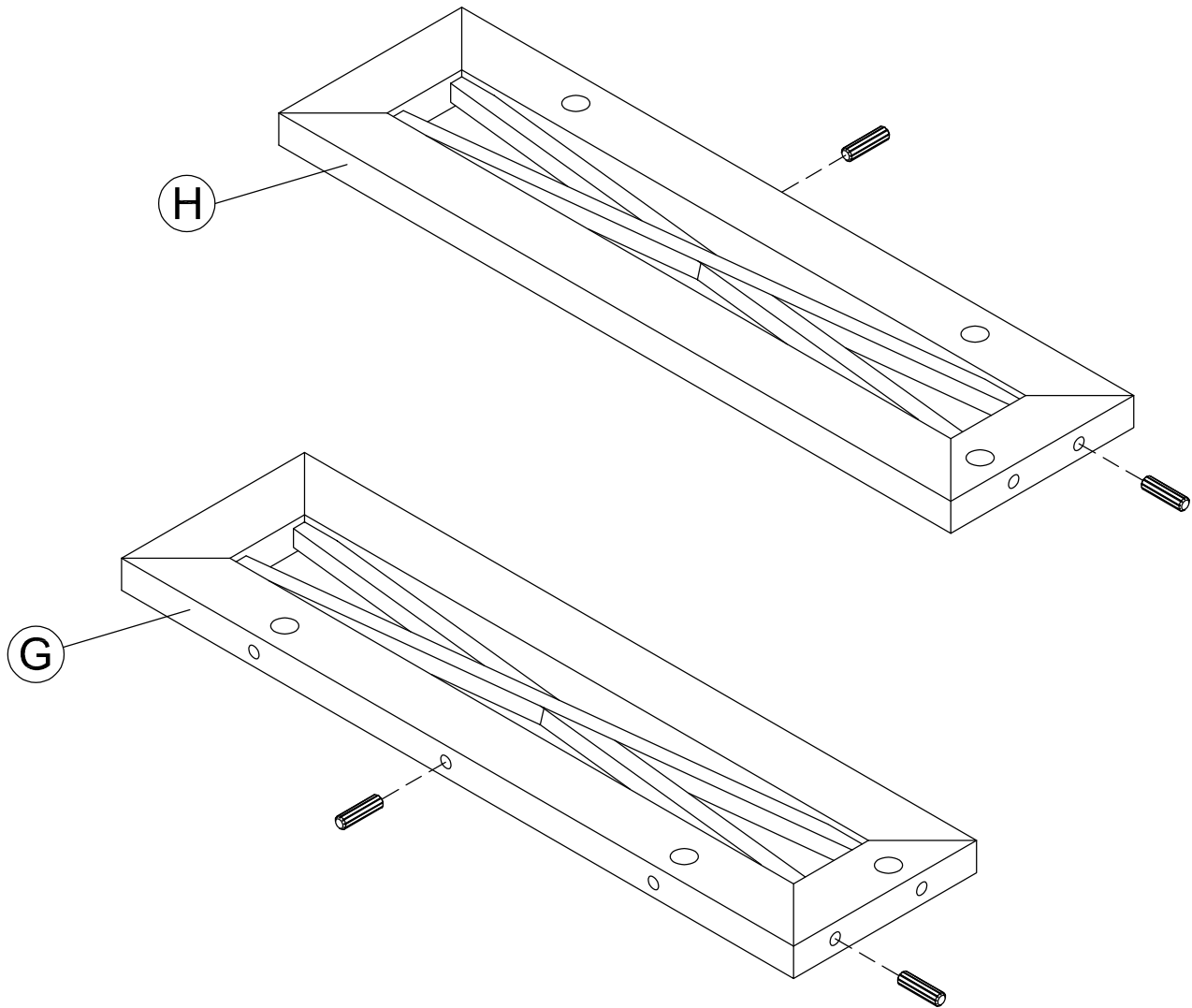

Safety glasses
Gafas de seguridad
Lunettes de protection

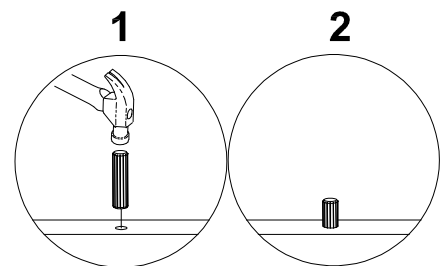

Have an assembly question or need a replacement part? Just call
1-800-950-4782, we are here to help.

H72988

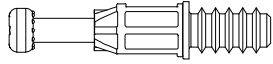

[4]

KD Bolt

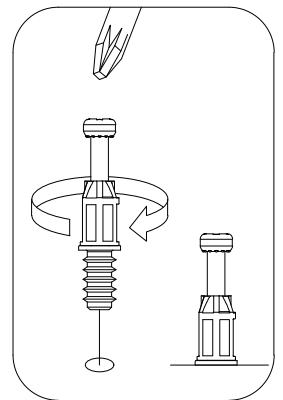
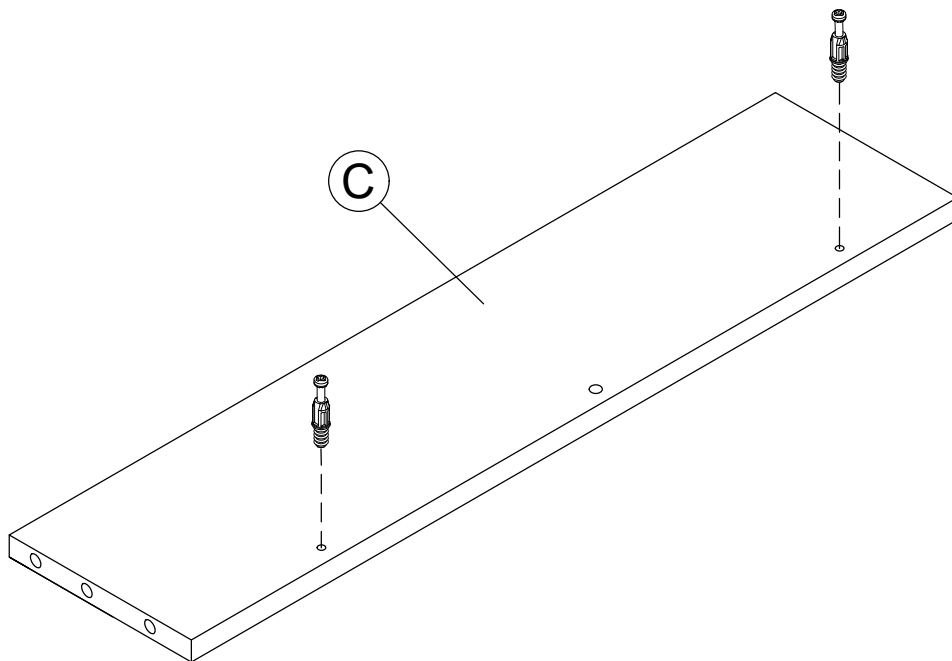
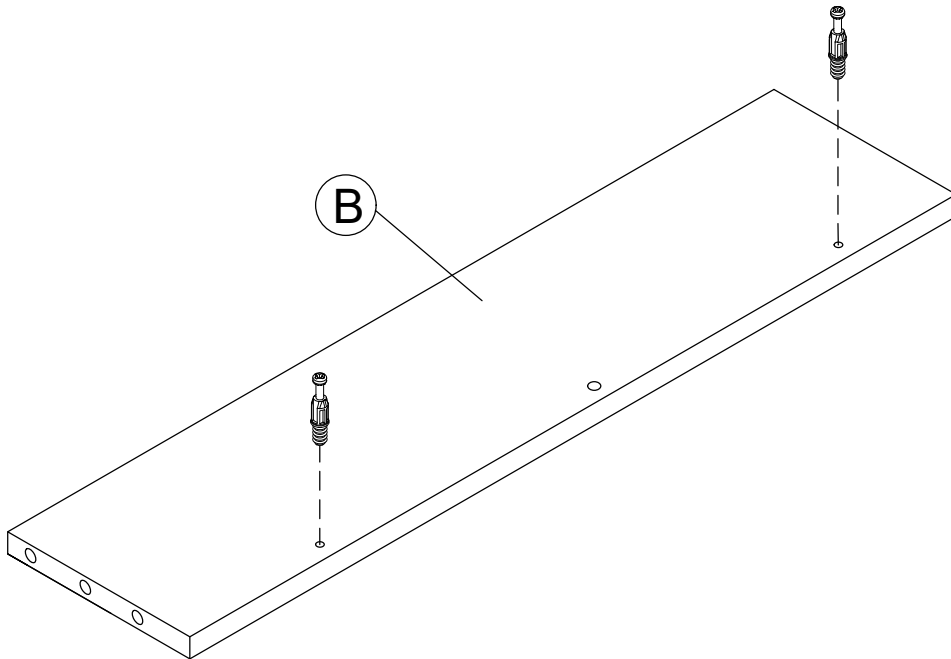

Have an assembly question or need a replacement part? Just call
1-800-950-4782, we are here to help.

Left Option

Go to step 7
Proceda al paso 7
Allez a l'etape 7

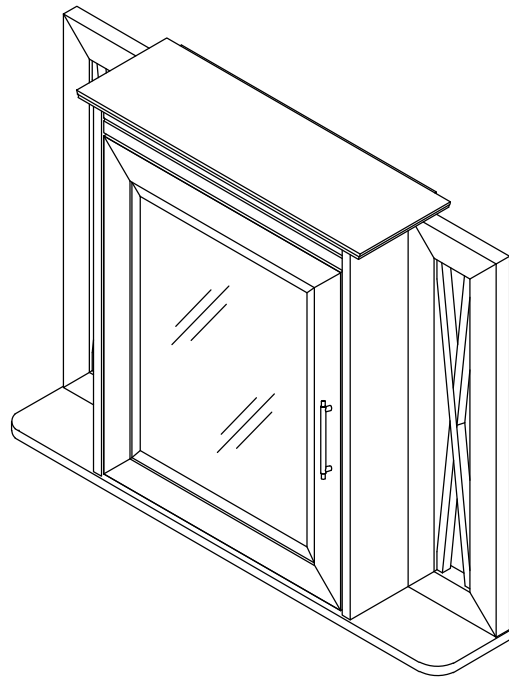

Right Option

Go to step 15
Proceda al paso 15
Allez a l'etape 15

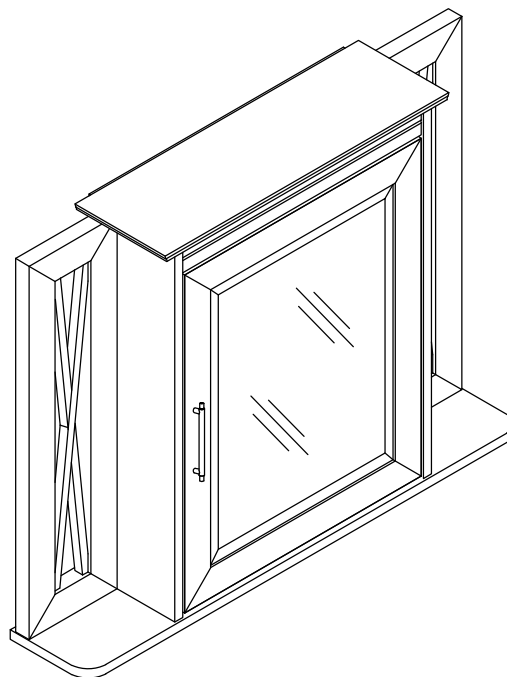

Have an assembly question or need a replacement part? Just call
1-800-950-4782, we are here to help.

STEP 7

Prepare Panels

A217161

H72988

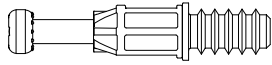

[2]

KD Bolt

H38169

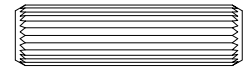

[4]

Wood Dowel
8 x 30mm

H170612

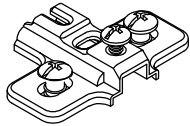

[2]

Mounting Plate

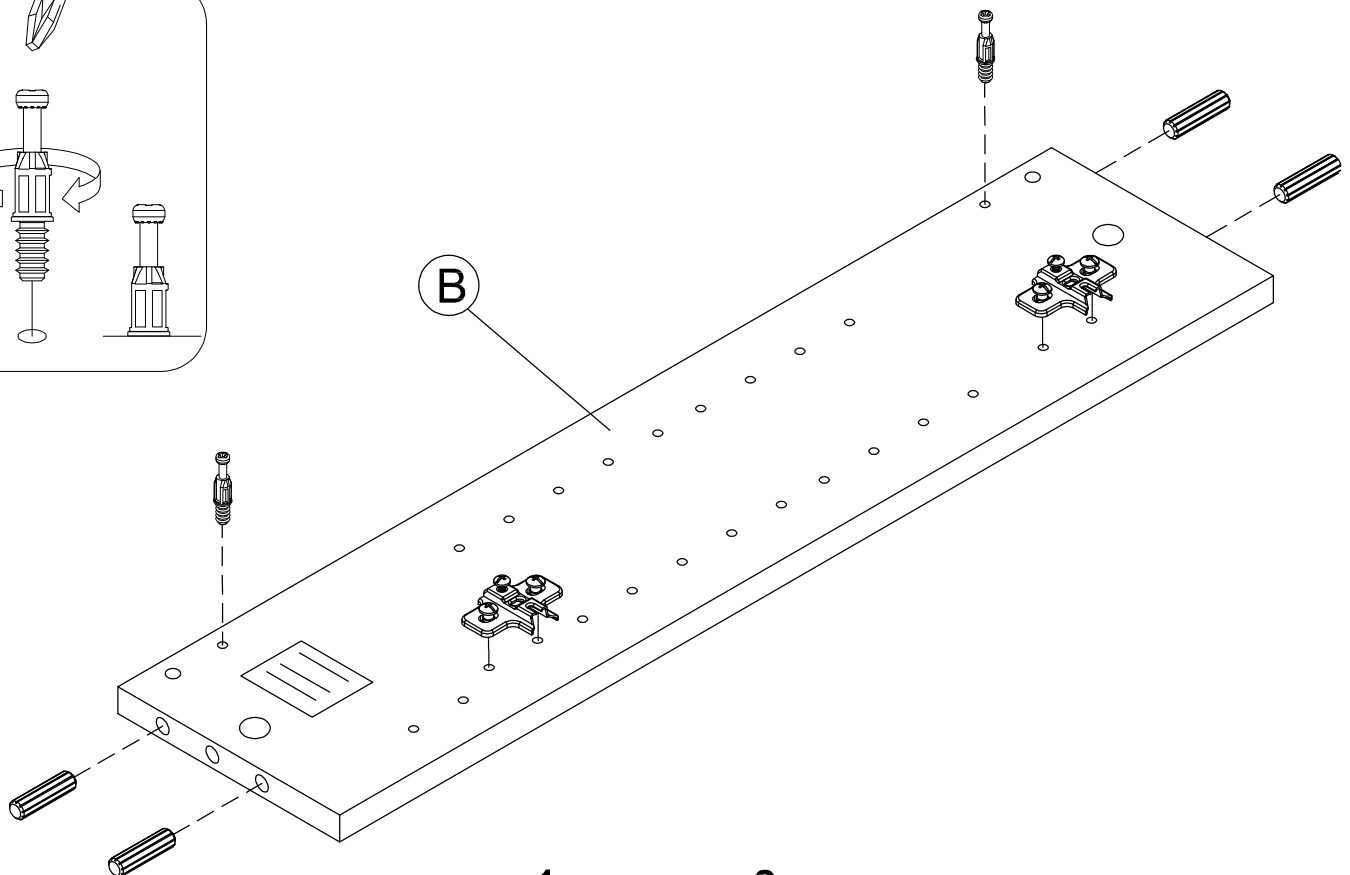
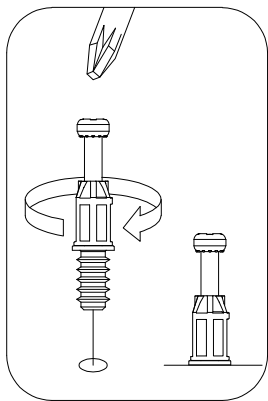

B

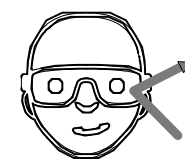
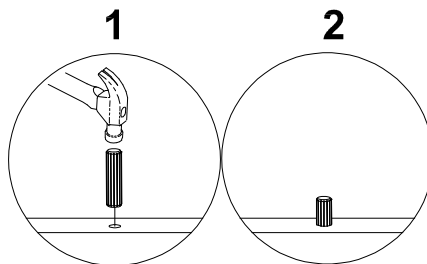

Safety glasses
Gafas de seguridad
Lunettes de protection

Have an assembly question or need a replacement part? Just call
1-800-950-4782, we are here to help.

STEP 8

Prepare Panels

A217161

H72988

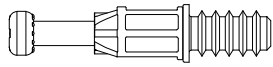

[2]

KD Bolt

H38169



[4]

Wood Dowel
8 x 30mm

H200012

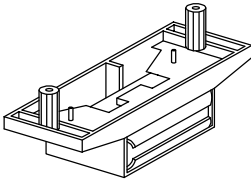

[1]

Magnetic Top

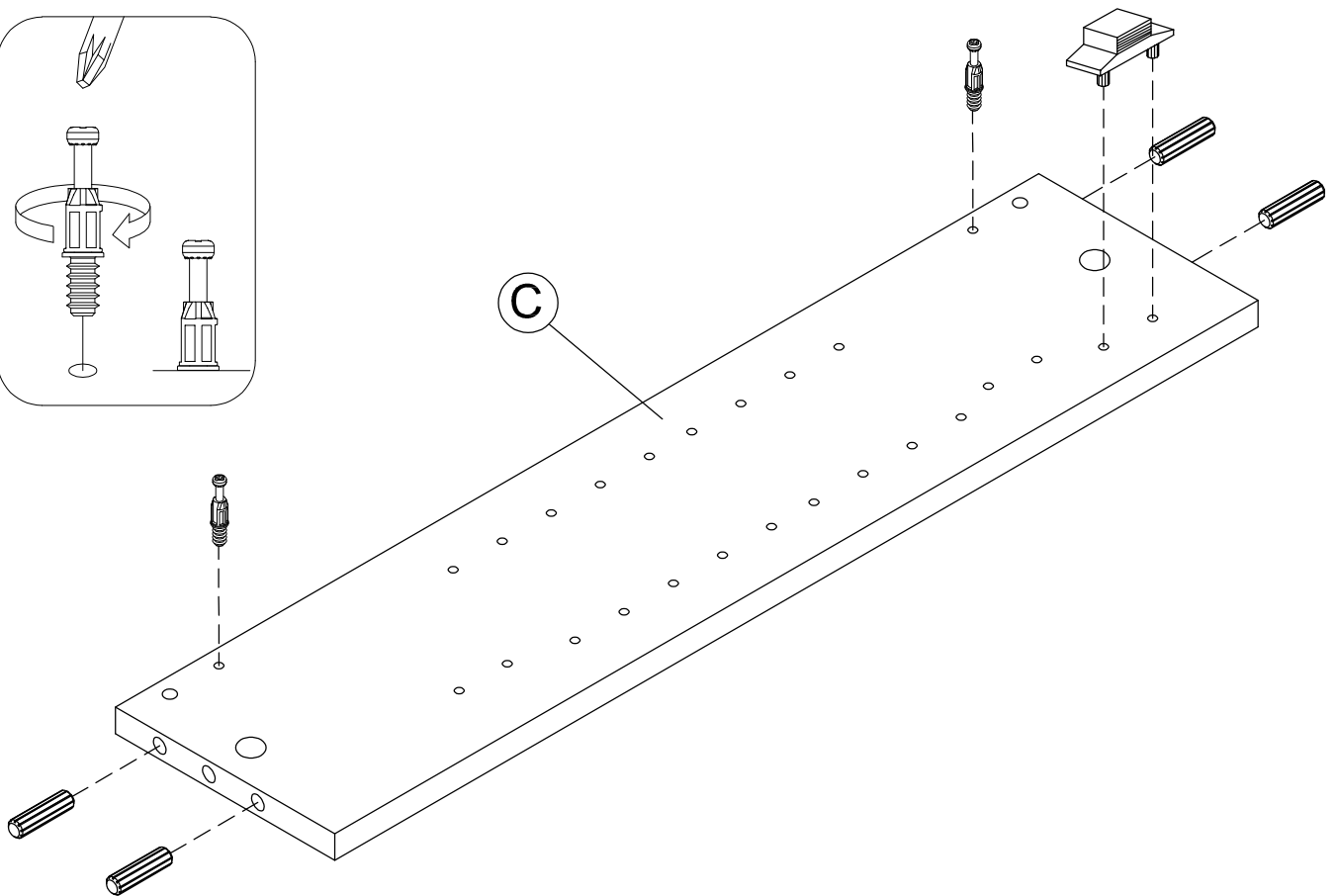
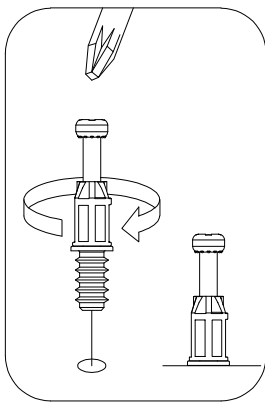

1

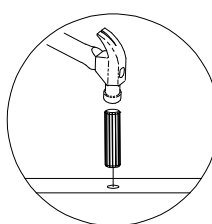

2

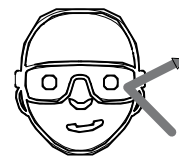
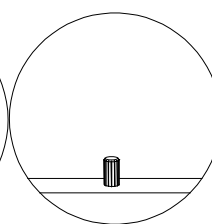

Safety glasses
Gafas de seguridad
Lunettes de protection

Have an assembly question or need a replacement part? Just call
1-800-950-4782, we are here to help.

STEP 9

Assemble Panels

A217161

Scan QR Code to Watch Video on:



How to Tighten KD Cams

H181468

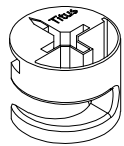

KD Cam

[2]

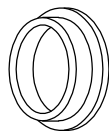

Hole Plug

[2]

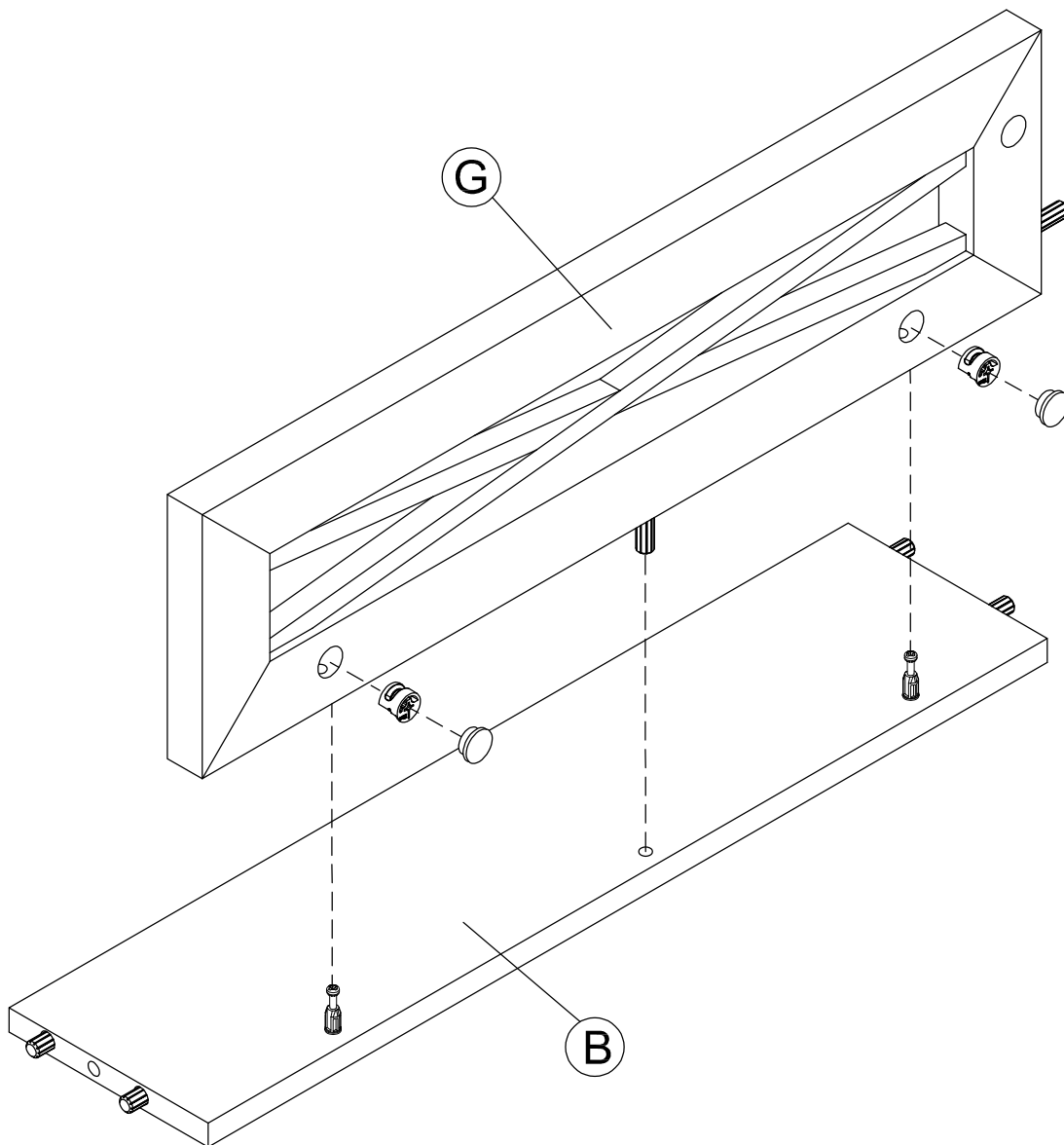
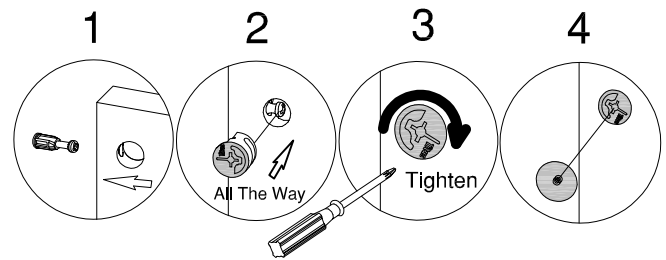

Have an assembly question or need a replacement part? Just call **1-800-950-4782**, we are here to help.

STEP 10

Assemble Panels

A217161

Scan QR Code to Watch Video on:



How to Tighten KD Cams

H181468

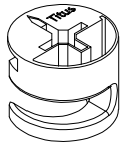

KD Cam

[2]

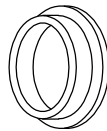

Hole Plug

[2]

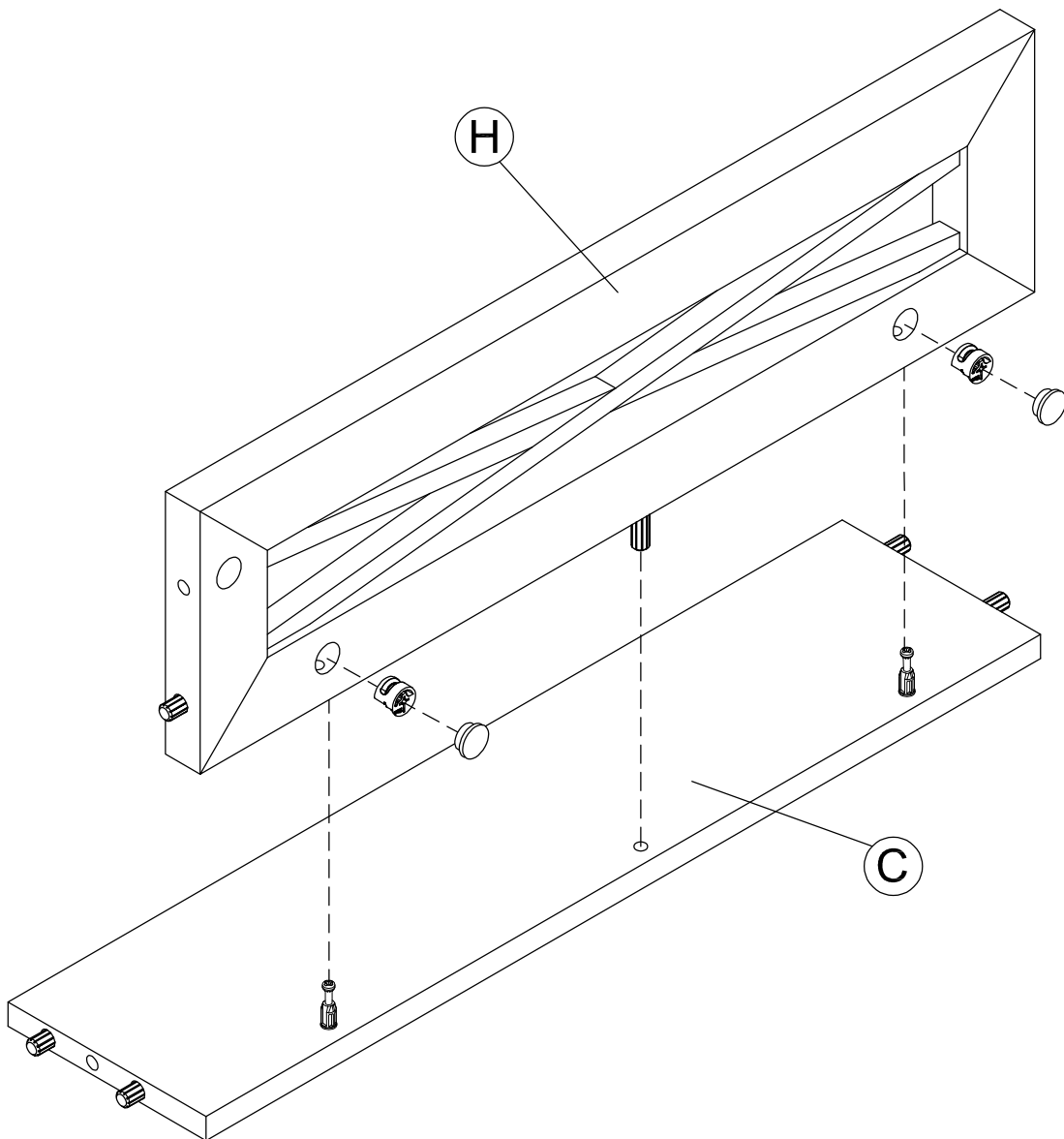
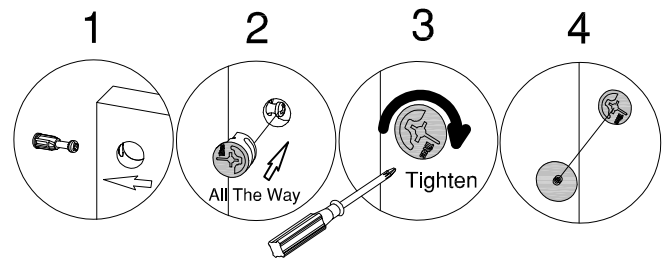

Have an assembly question or need a replacement part? Just call **1-800-950-4782**, we are here to help.

STEP 11

Assemble Panels

A217161

Scan QR Code to Watch Video on:



How to Tighten KD Cams

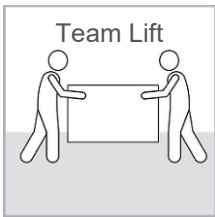

H181468

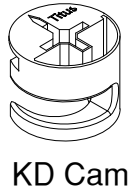

[2]

KD Cam

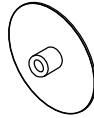

[2]

Cover Cap

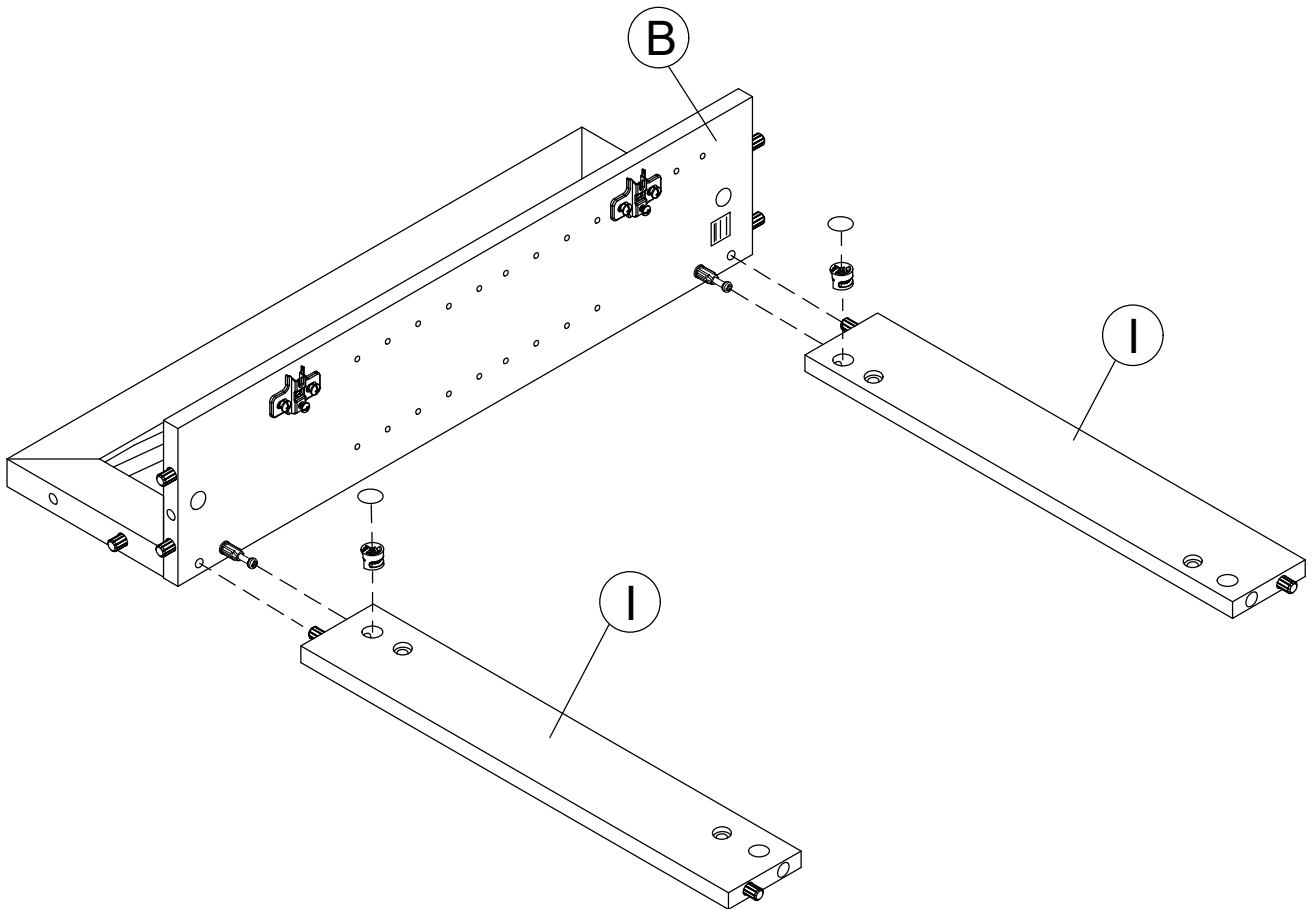
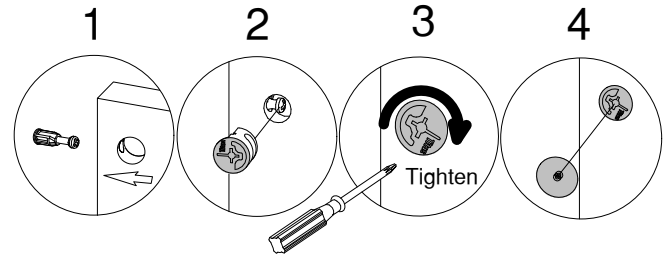

Have an assembly question or need a replacement part? Just call **1-800-950-4782**, we are here to help.

STEP 12

Assemble Panels

A217161

Scan QR Code to Watch Video on:



How to Tighten KD Cams

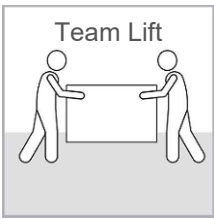

H181468

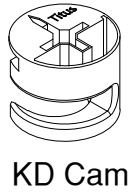

[2]

KD Cam

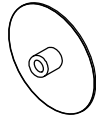

[2]

Cover Cap

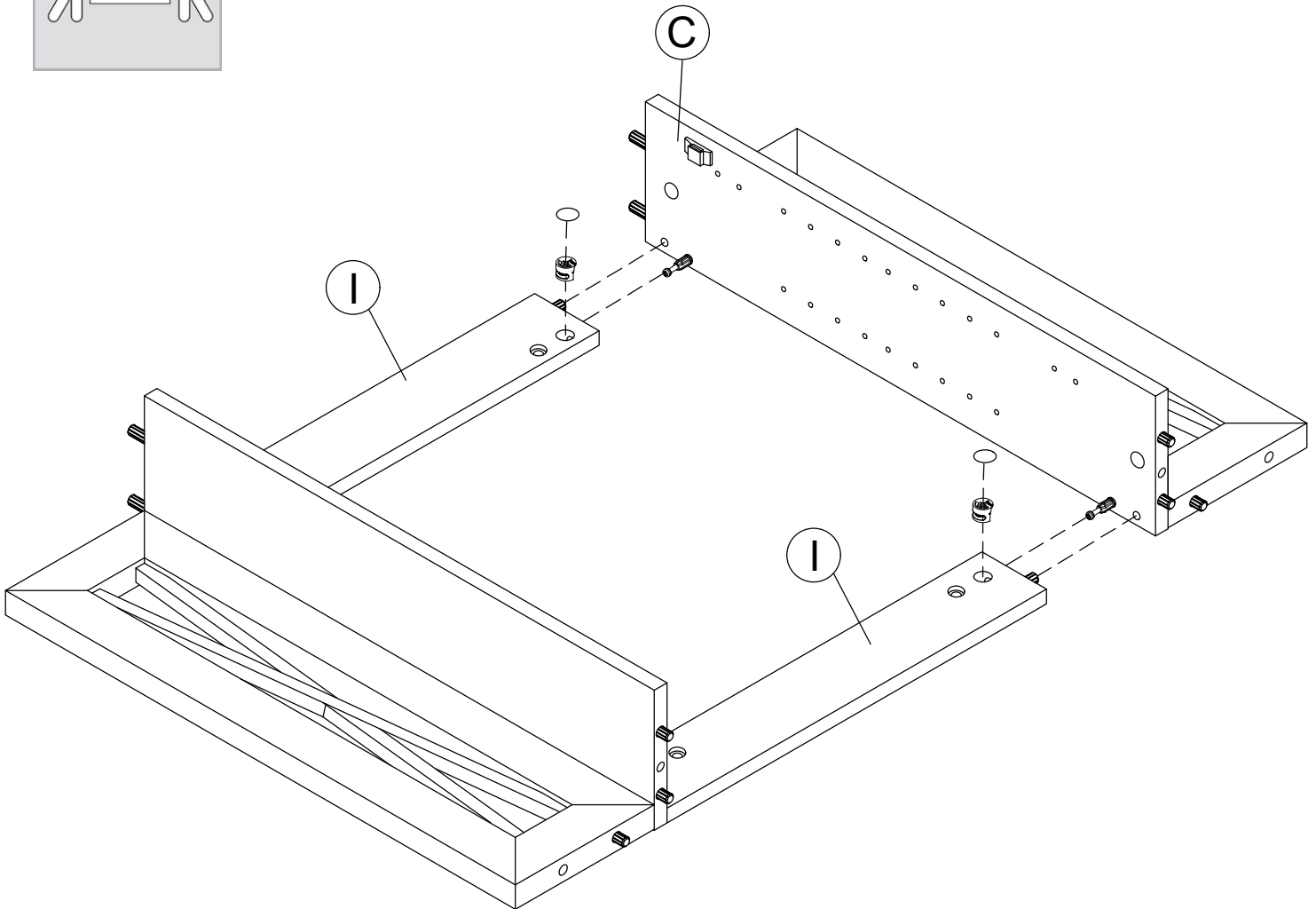
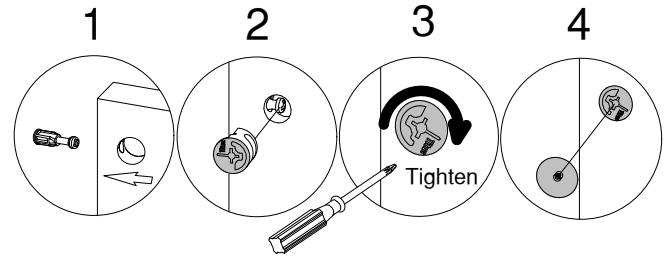

Have an assembly question or need a replacement part? Just call **1-800-950-4782**, we are here to help.

STEP 13

Assemble Panels

A217161

Scan QR Code to Watch Video on:



How to Tighten KD Cams

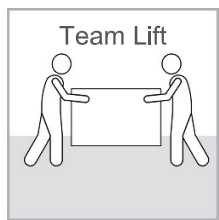

H181468

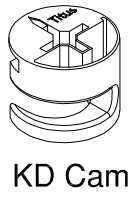

[4]

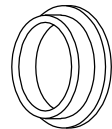

[2]

Hole Plug

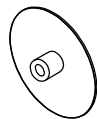

[2]

Cover Cap

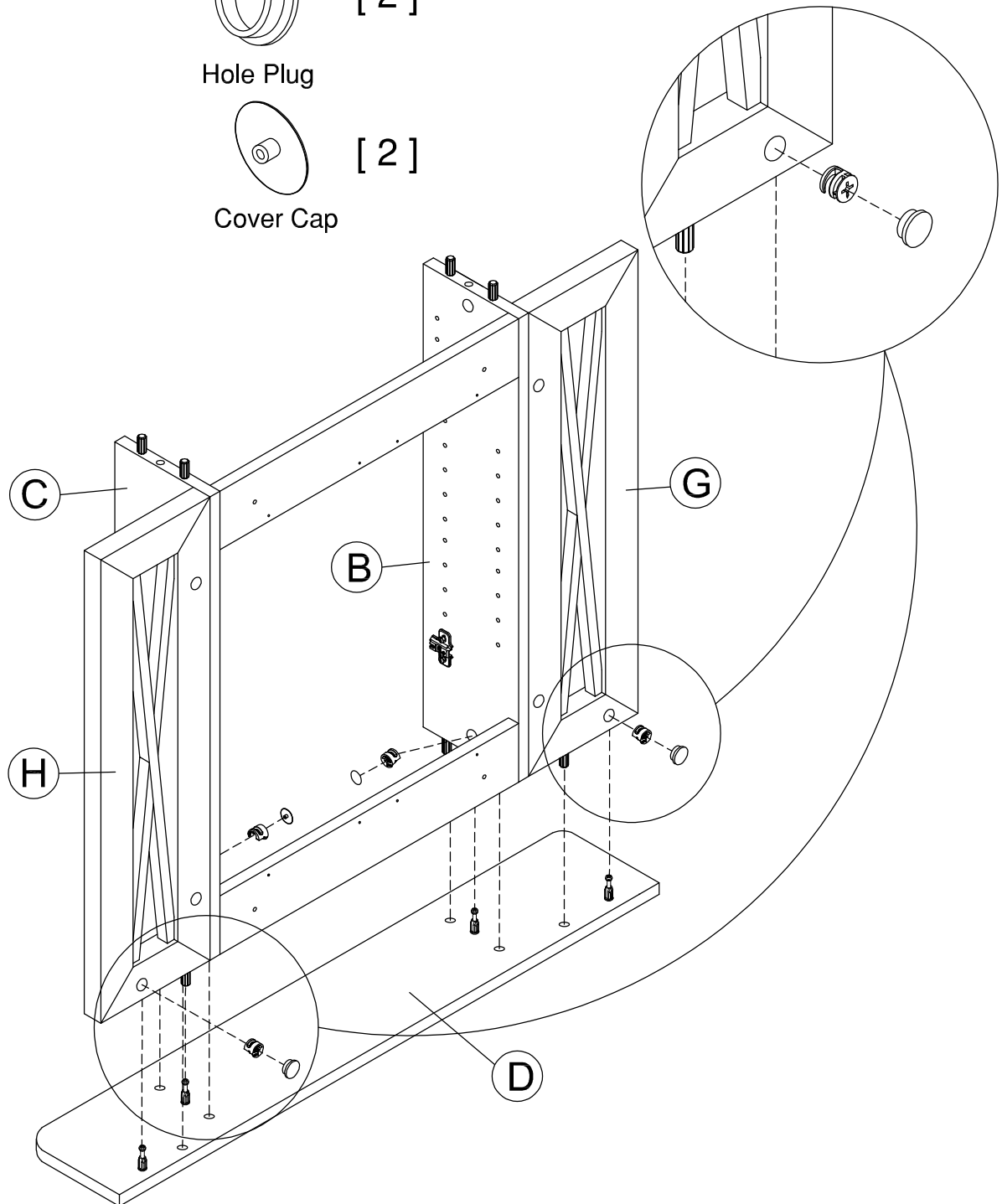
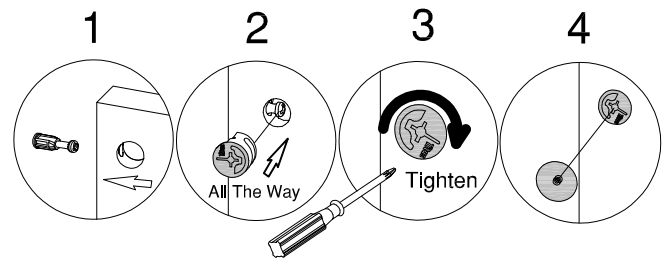

Have an assembly question or need a replacement part? Just call **1-800-950-4782**, we are here to help.

STEP 14

Assemble Panels

A217161

Scan QR Code to
Watch Video on:



How to Tighten
KD Cams

H181468

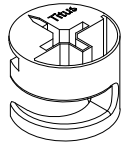

[2]

KD Cam

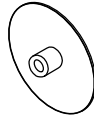

[2]

Cover Cap

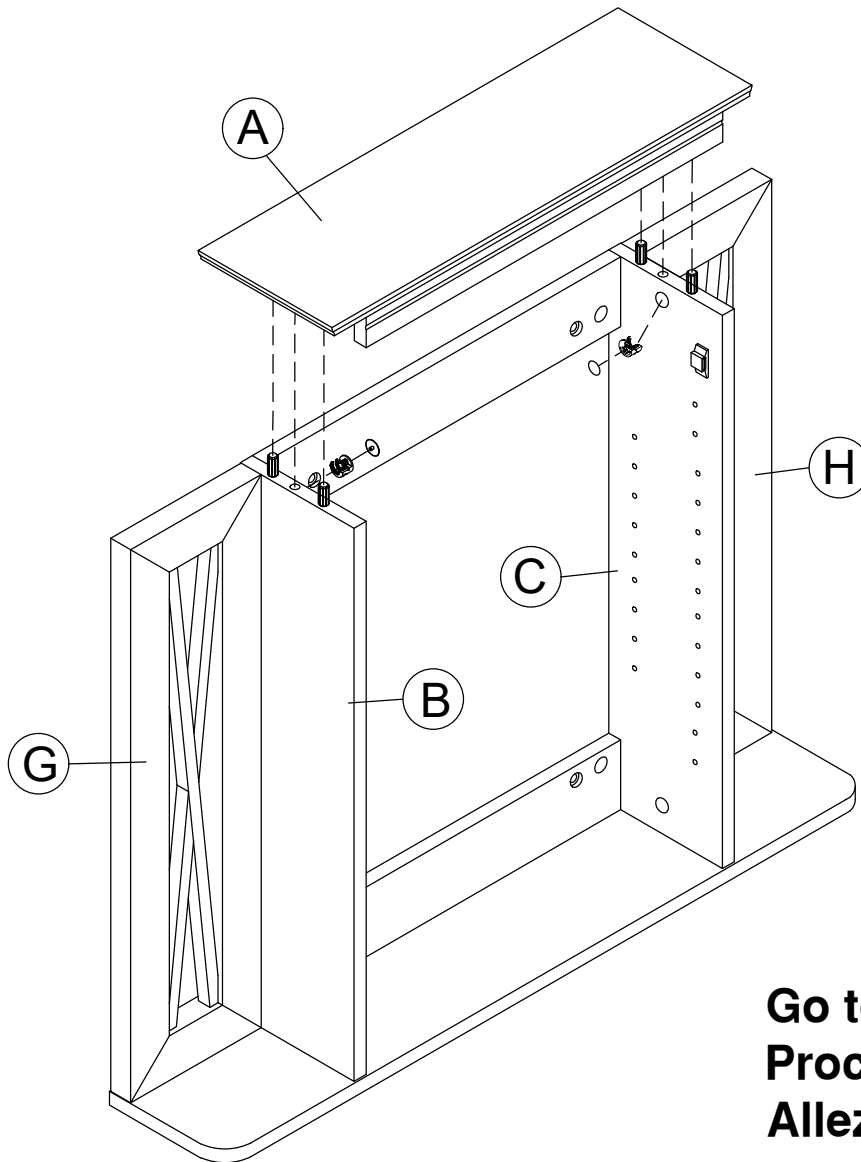
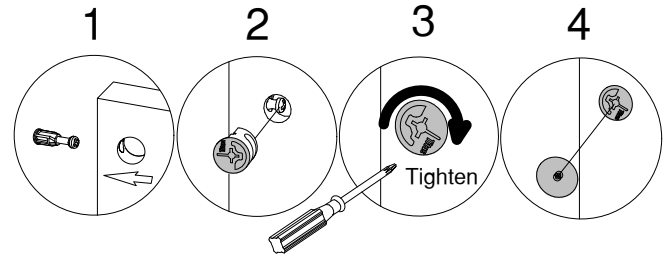

Go to step 23
Proceda al paso 23
Allez a l'etape 23

Have an assembly question or need a replacement part? Just call
1-800-950-4782, we are here to help.

STEP 15

Prepare Panels

A217161

H72988

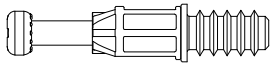

KD Bolt

[2]

H38169

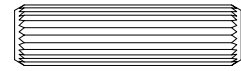

Wood Dowel
8 x 30mm

[4]

H200012

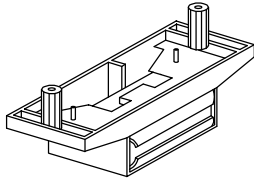

Magnetic Top

[1]

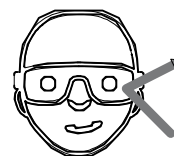
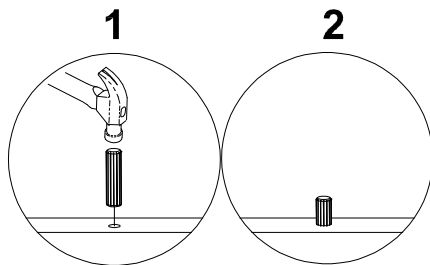
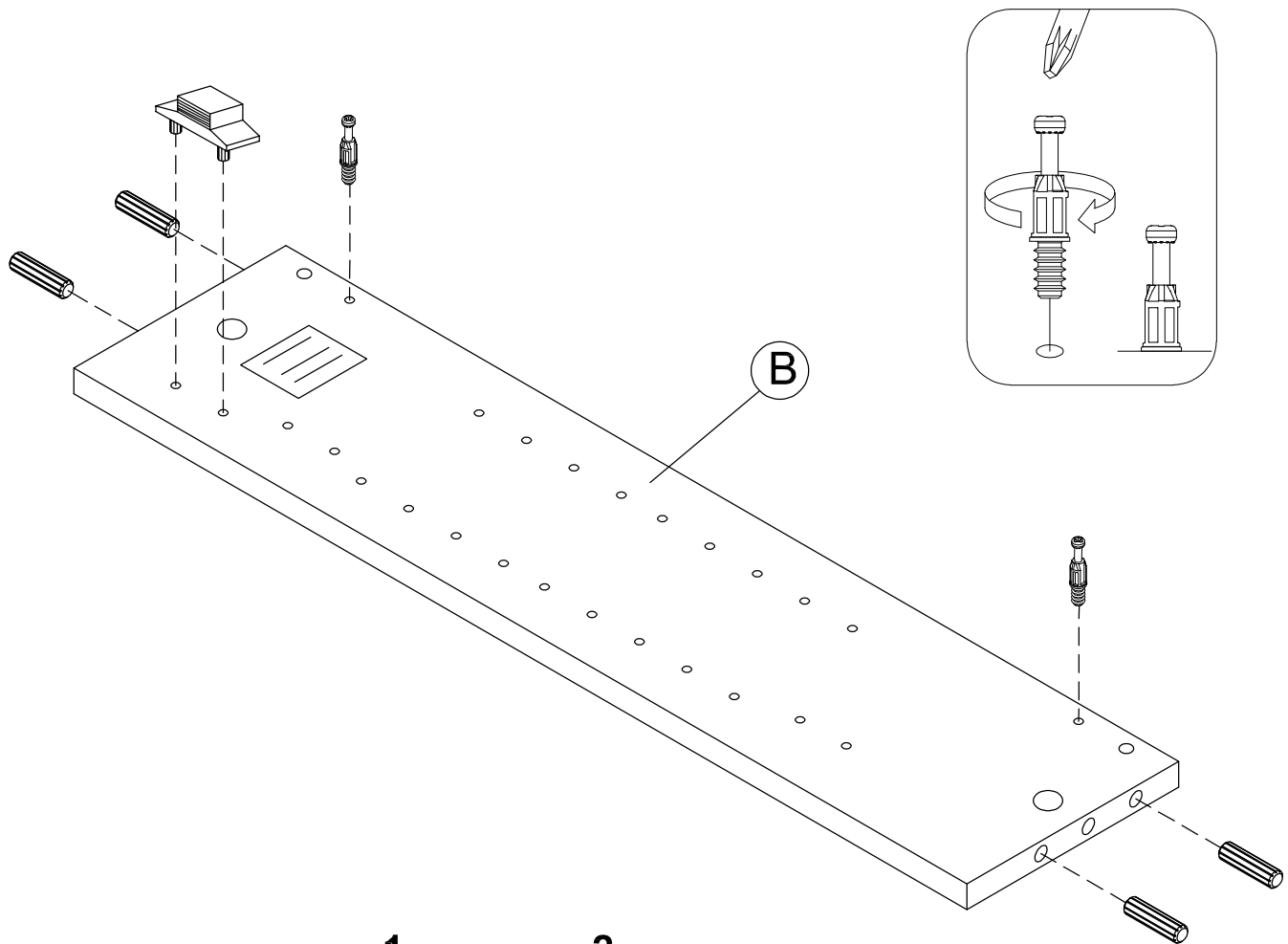

Safety glasses
Gafas de seguridad
Lunettes de protection

Have an assembly question or need a replacement part? Just call
1-800-950-4782, we are here to help.

STEP 16

Prepare Panels

A217161

H72988

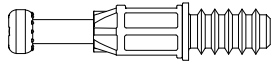

[2]

KD Bolt

H38169



[4]

Wood Dowel
8 x 30mm

H170612

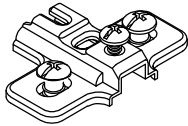

[2]

Mounting Plate

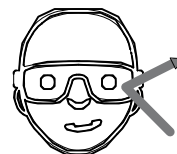
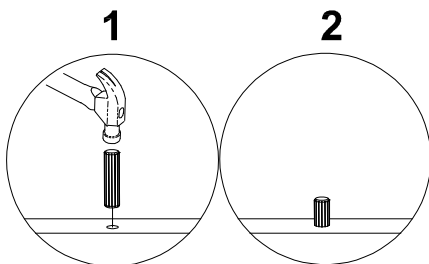
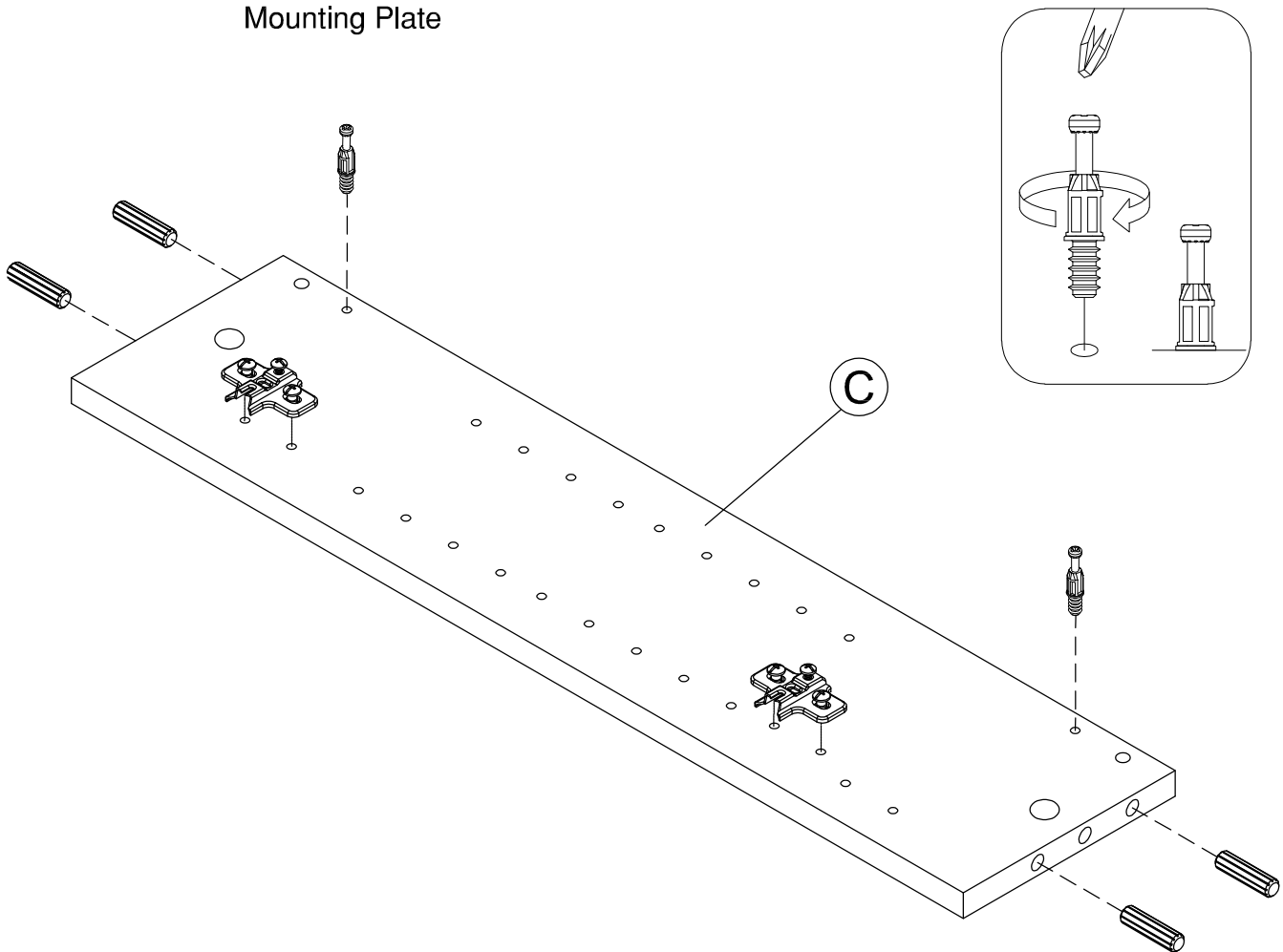

Safety glasses
Gafas de seguridad
Lunettes de protection

Have an assembly question or need a replacement part? Just call
1-800-950-4782, we are here to help.

STEP 17

Assemble Panels

A217161

Scan QR Code to Watch Video on:



How to Tighten KD Cams

H181468

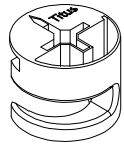

[2]

KD Cam

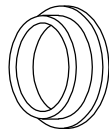

[2]

Hole Plug

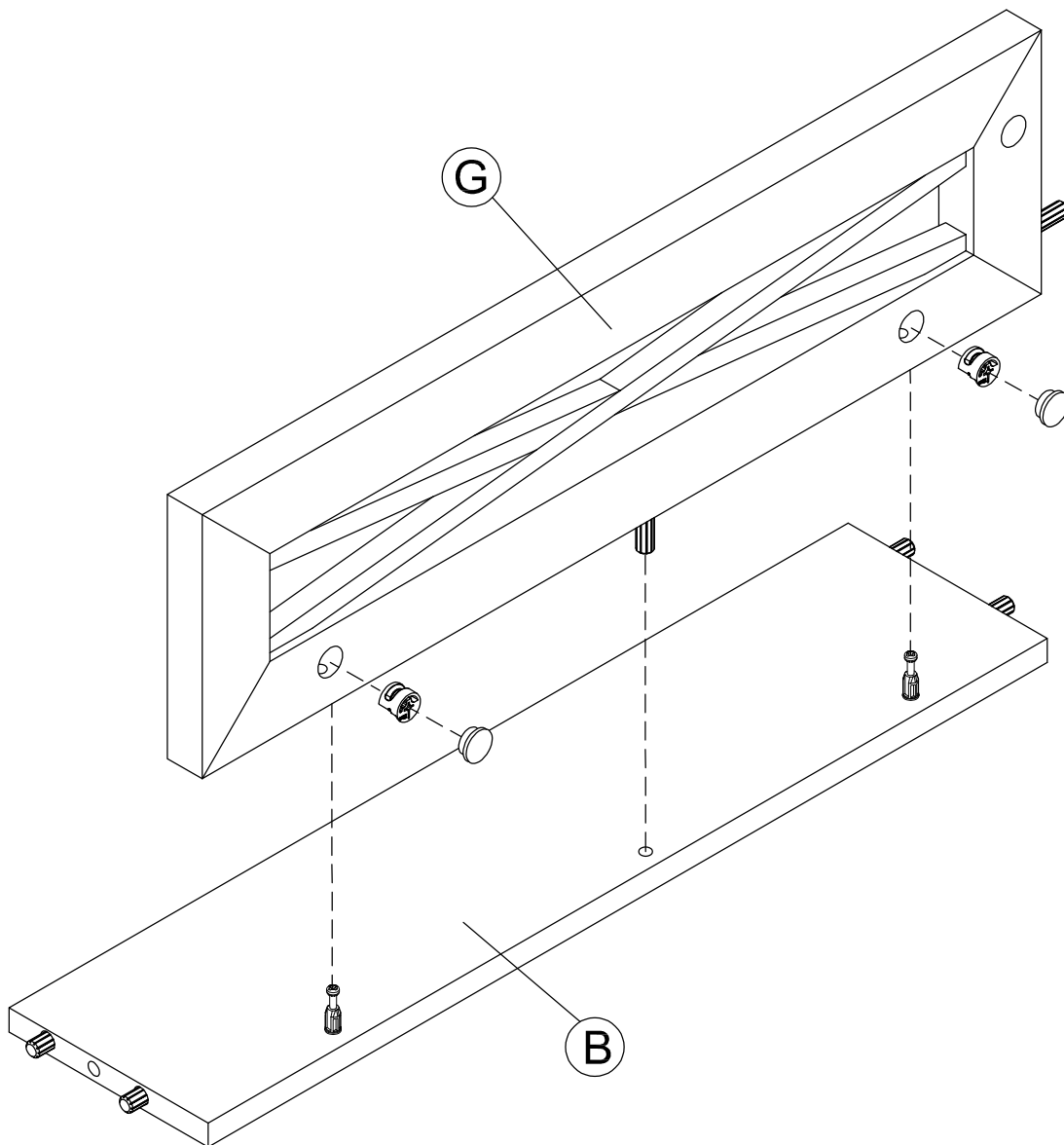
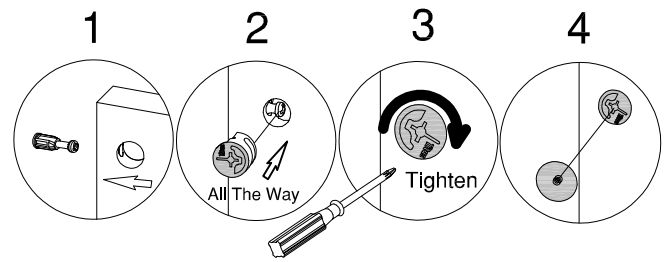

Have an assembly question or need a replacement part? Just call **1-800-950-4782**, we are here to help.

STEP 18

Assemble Panels

A217161

Scan QR Code to Watch Video on:



How to Tighten KD Cams

H181468

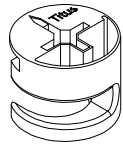

KD Cam

[2]

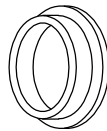

Hole Plug

[2]

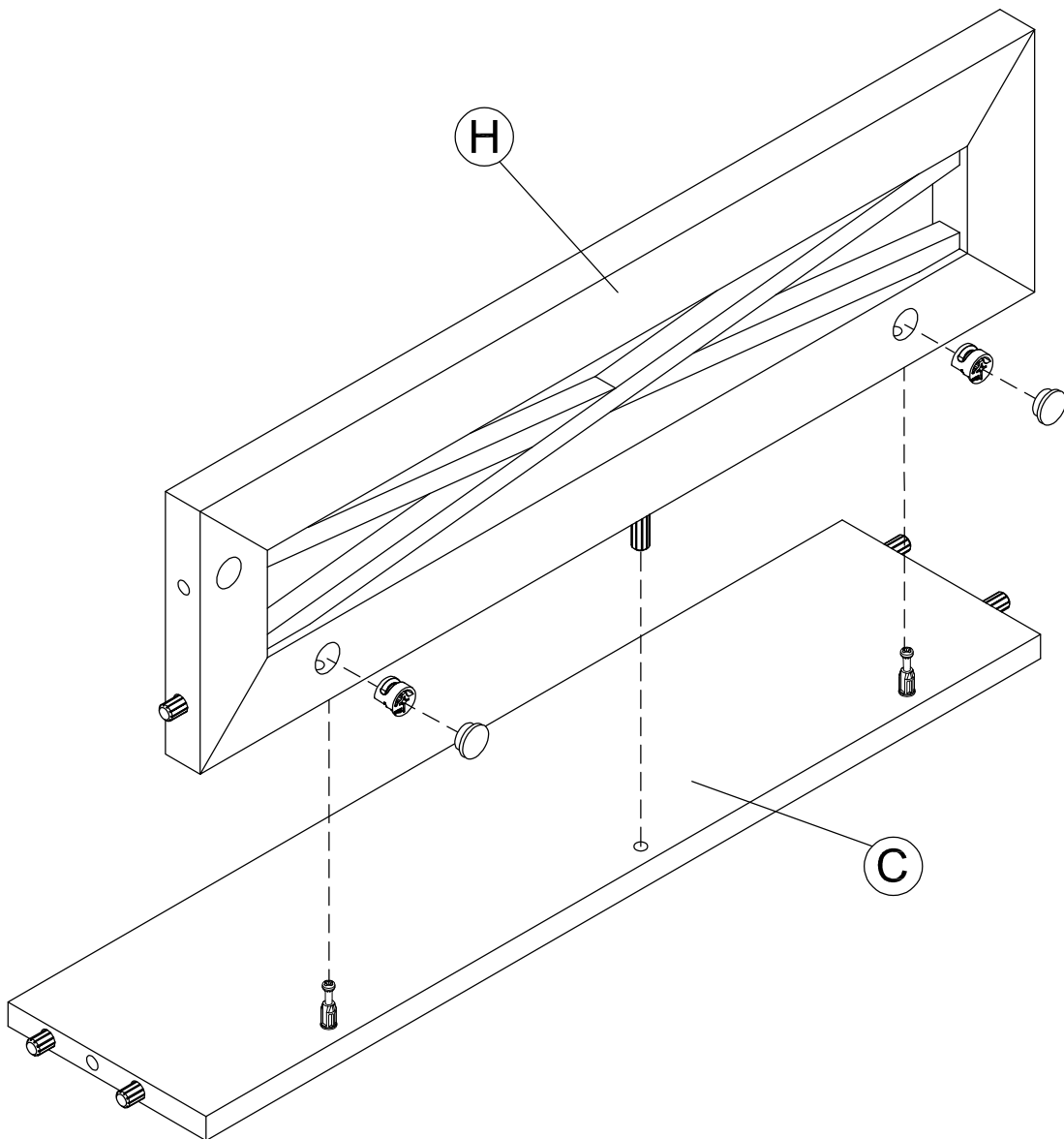
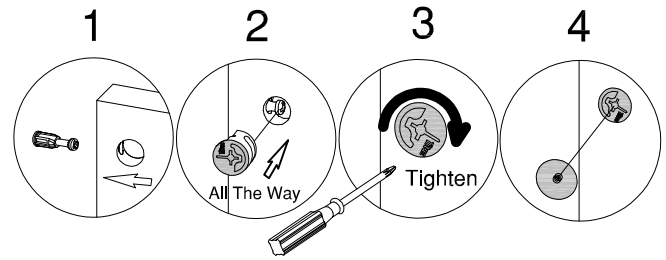

Have an assembly question or need a replacement part? Just call **1-800-950-4782**, we are here to help.

STEP 19

Assemble Panels

A217161

Scan QR Code to Watch Video on:



How to Tighten KD Cams

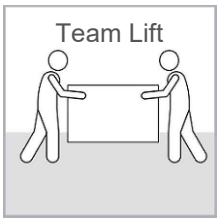

H181468

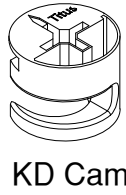

[2]

KD Cam

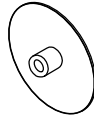

[2]

Cover Cap

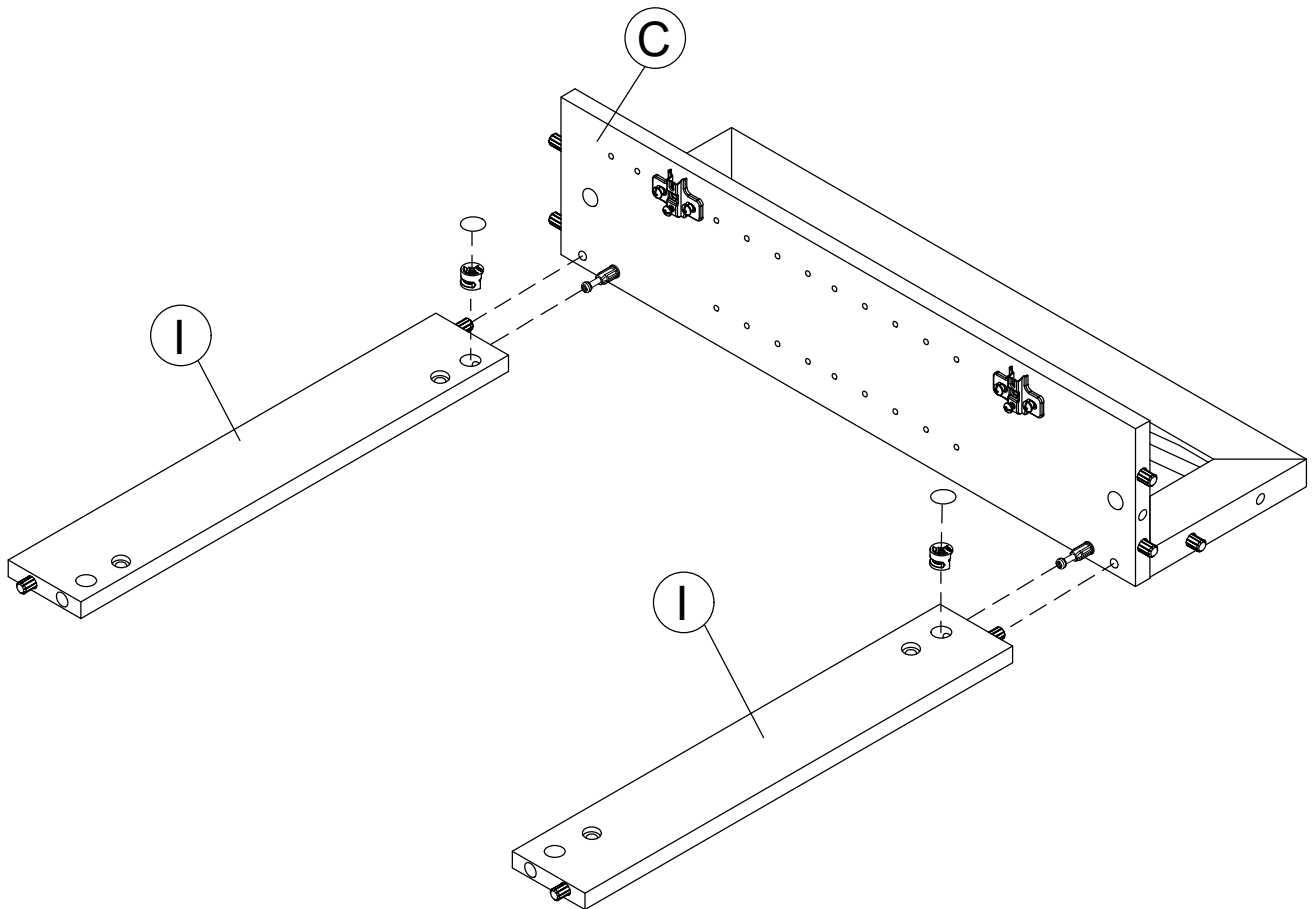
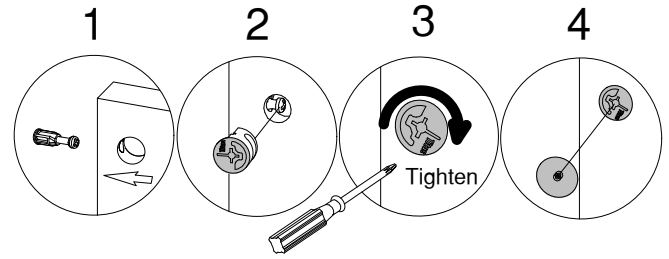

Have an assembly question or need a replacement part? Just call
1-800-950-4782, we are here to help.

STEP 20

Assemble Panels

A217161

Scan QR Code to Watch Video on:



How to Tighten KD Cams



H181468

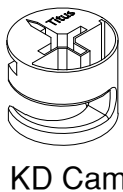

[2]

KD Cam



[2]

Cover Cap

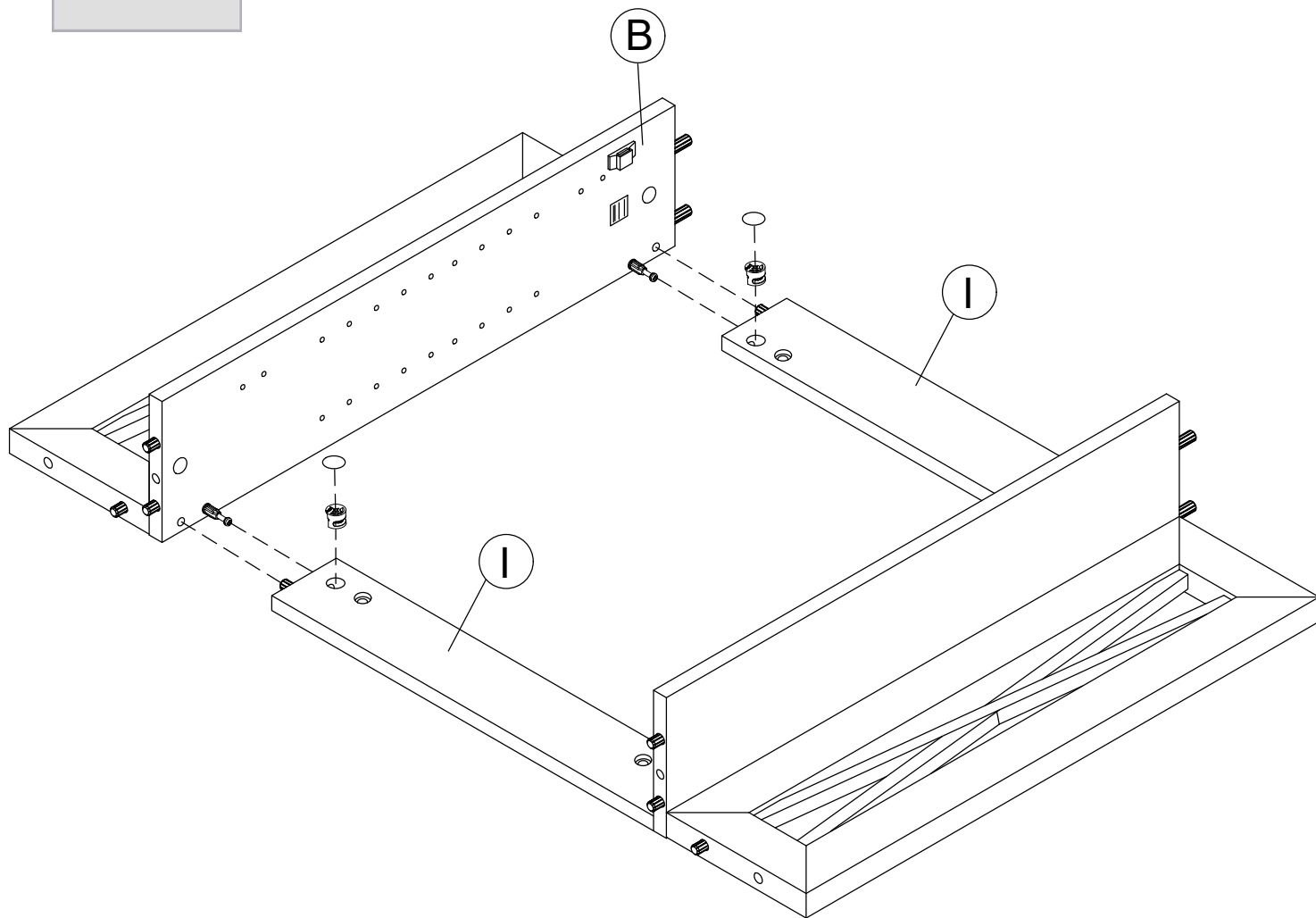
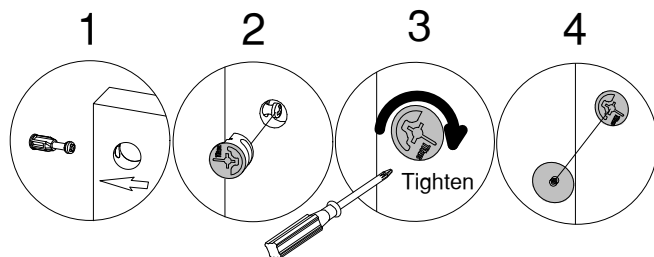

Have an assembly question or need a replacement part? Just call
1-800-950-4782, we are here to help.

STEP 21

Assemble Panels

A217161

Scan QR Code to Watch Video on:



How to Tighten KD Cams



H181468

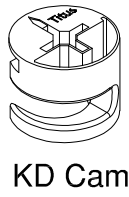

KD Cam

[4]

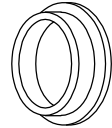

Hole Plug

[2]

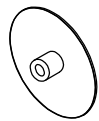

Cover Cap

[2]

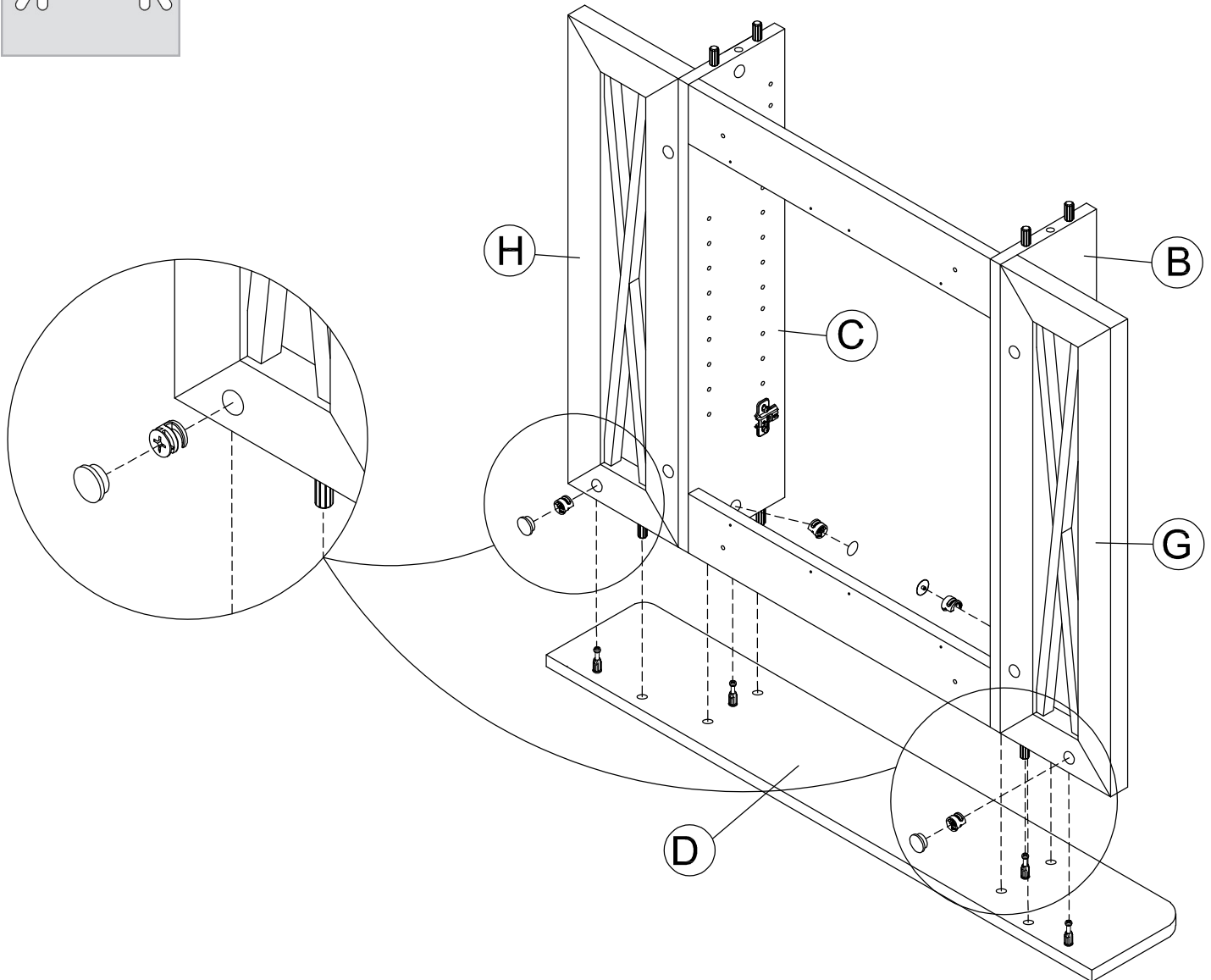
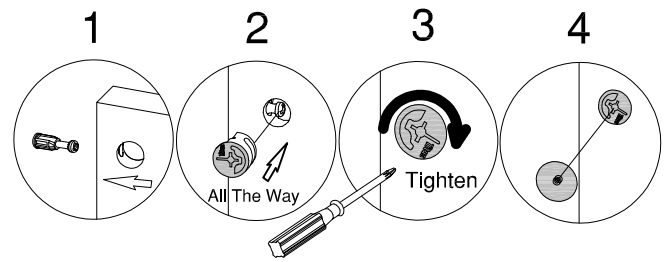

Have an assembly question or need a replacement part? Just call **1-800-950-4782**, we are here to help.

STEP 22

Assemble Panels

A217161

Scan QR Code to Watch Video on:



How to Tighten KD Cams

H181468

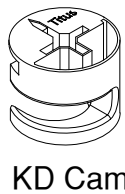

[2]

KD Cam

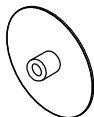

[2]

Cover Cap

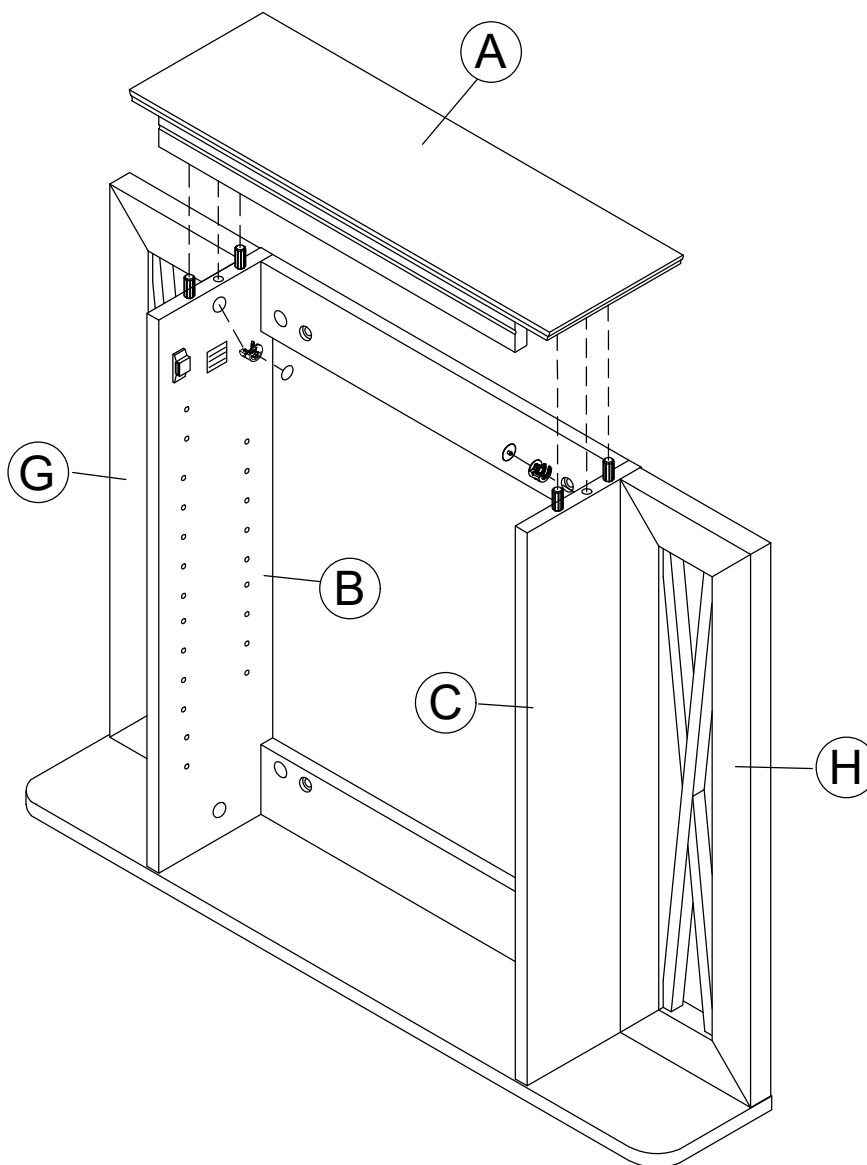
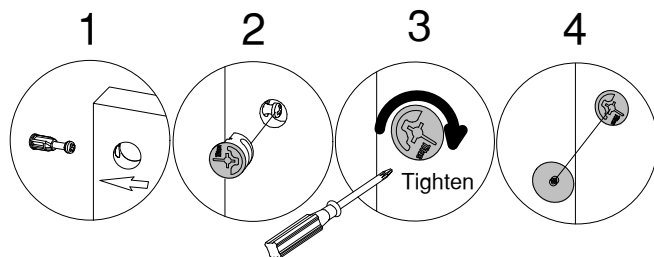

Have an assembly question or need a replacement part? Just call **1-800-950-4782**, we are here to help.

STEP 23

Attach Back Panel

A217161

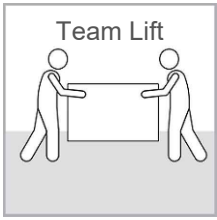

H34174

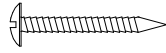

[8]

3 x 3/4"

H124395

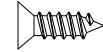

[8]

#6 x 1/2"

Center the back panel so that the back panel does not stick out past the edge of the unit.

Centrez le panneau arrière de manière à ce qu'il ne reste pas au-delà du bord de l'appareil.

Centre el panel posterior de modo que el panel posterior no se pegue más allá del borde de la unidad.

H124395

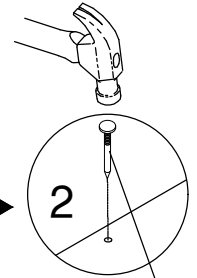
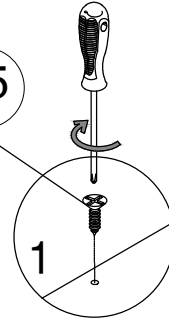

H34174

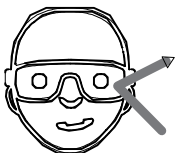
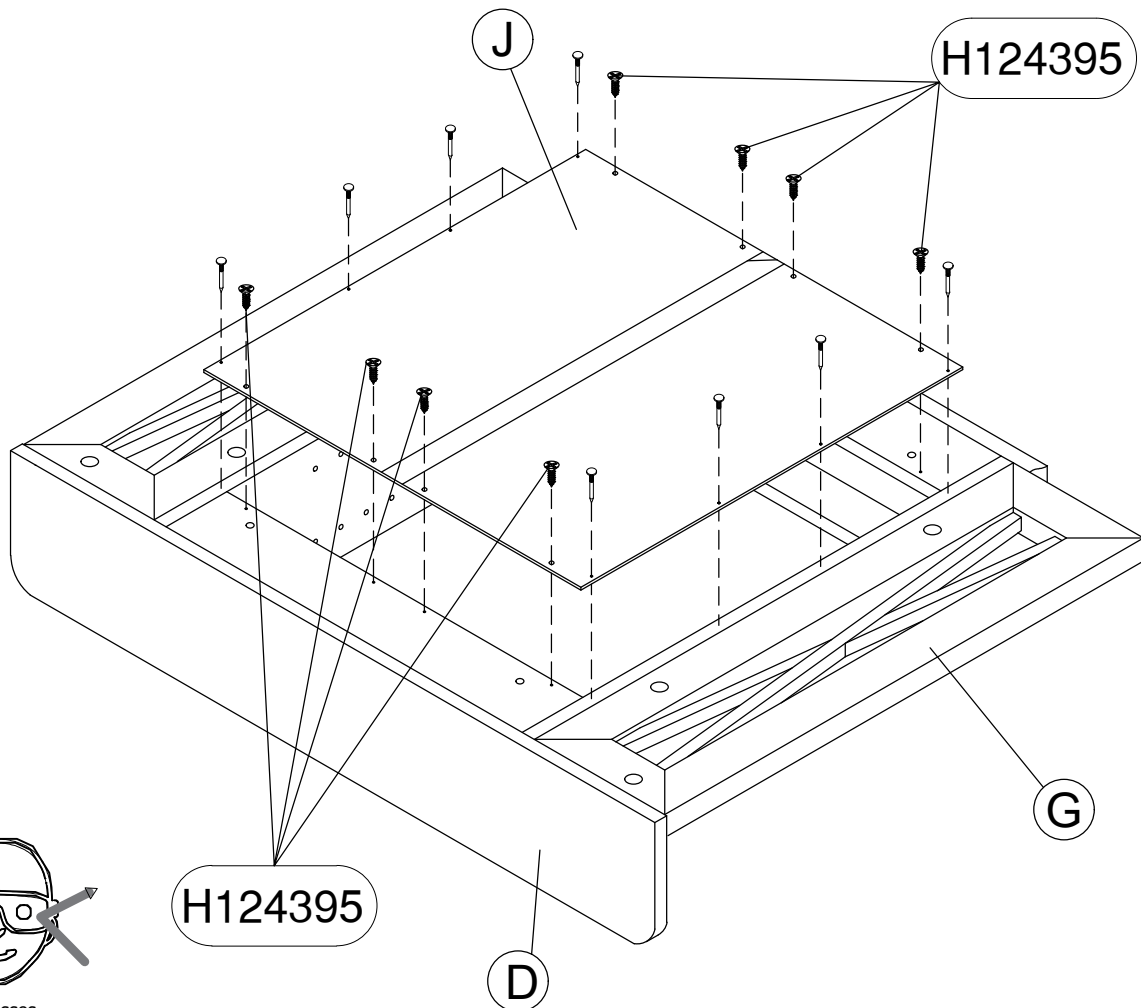

Safety glasses
Gafas de seguridad
Lunettes de protection

Have an assembly question or need a replacement part? Just call
1-800-950-4782, we are here to help.

Scan QR Code to Watch Video on:



Wall Mounted Cabinet Attachment to Wall Studs

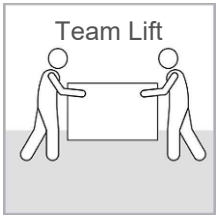

Cabinet is predrilled for wall mounting and can attach directly to wood wall studs or a hollow wall. You may need to use both wall stud and hollow-wall anchors provided. Procedure:

1. Place cabinet in the desired final location.
2. With a helper to hold the Cabinet in position, verify the cabinet is level.
3. Lightly mark wall at top and side of cabinet.
4. Insert #10 x 2.5" screw (H217165) into (4) mounting holes and push firmly or tap lightly with hammer to mark wall for drilling.
5. Set Cabinet aside

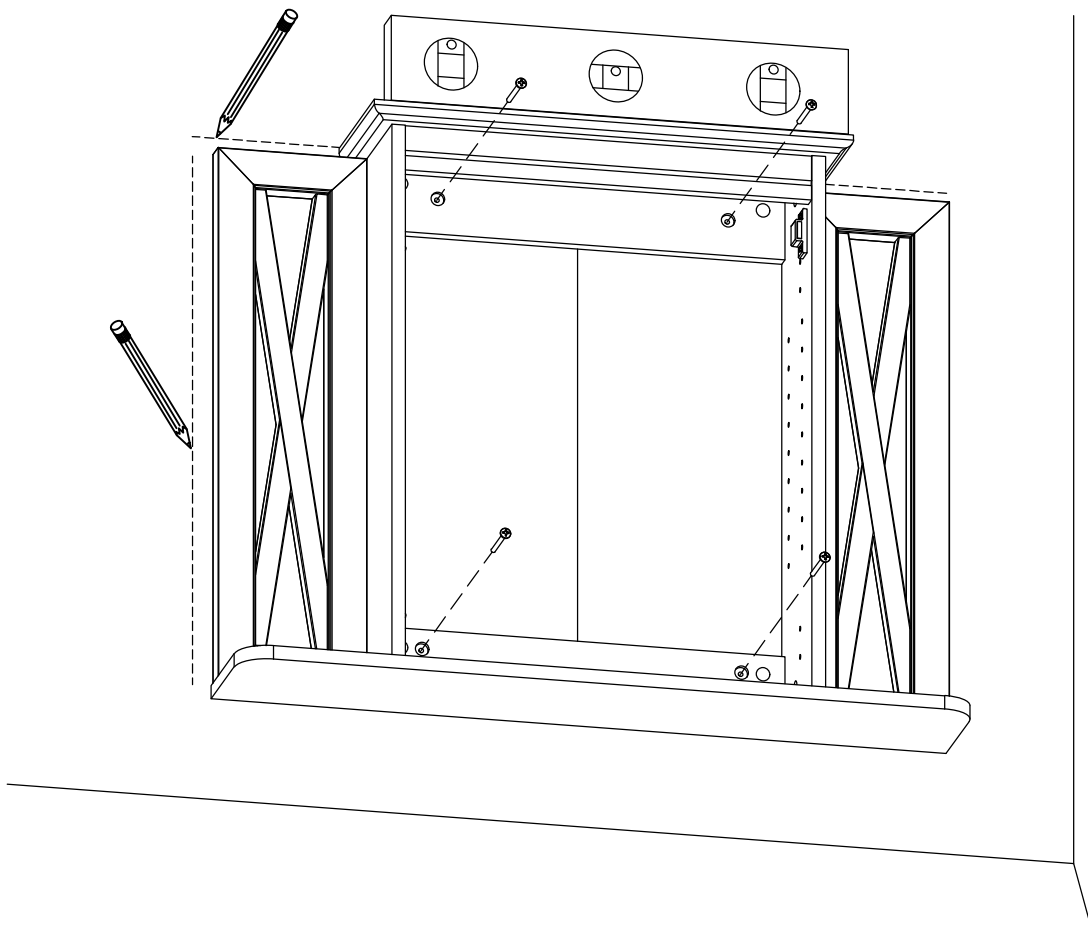
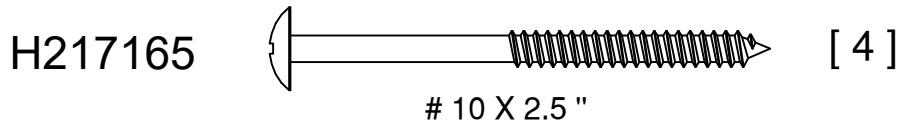

Have an assembly question or need a replacement part? Just call **1-800-950-4782**, we are here to help.

NOTE: There may be plumbing or electrical lines in the walls of residential dwellings. Care must be taken when drilling into walls. If you are not confident in your installation abilities, please consult an installation professional.

1. Mark hole locations with pencil.
2. At marked locations, drill (4) 1/8" (3mm) holes just through hollow wall 1/2 to 3/4" (12-19mm) deep or 2" (50mm) deep if wood stud is encountered.
3. Make note on diagram below if a wall stud is encountered during this step. Hollow wall anchor H200009 must be installed into any hole where stud was not encountered (see step 17). There may be situations where both hollow wall anchors and long-screw stud anchors are used.
4. Install Wall Anchor H200009 into holes where wall stud was not found.

H200009

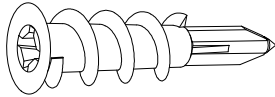

[4]

Wall Anchor

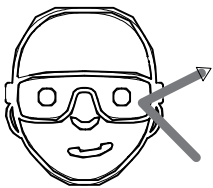

Safety glasses
Gafas de seguridad
Lunettes de protection

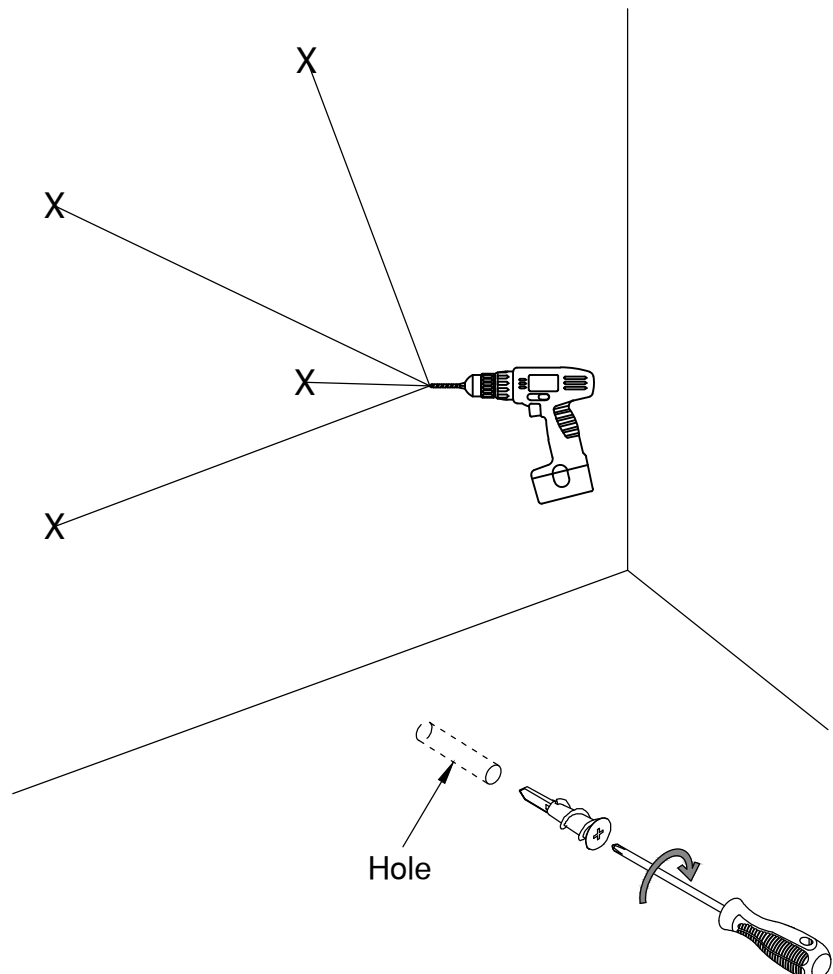

Have an assembly question or need a replacement part? Just call
1-800-950-4782, we are here to help.

STEP 26

Attach to Wall

A217161

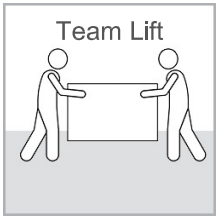

1. With assistant align cabinet with pencil marks from step 15 and drilled wall holes or wall anchors.
2. Using diagram from step 16, choose screw H217165 for holes into wall studs and screw H107572 for attachment to Wall Anchor.

H217165

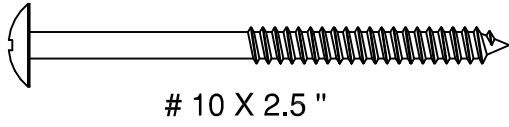

[4]

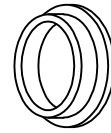

[4]

H107572

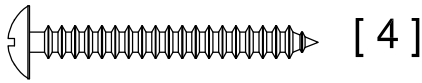

[4]

#8x1-1/2"

Hole Plug

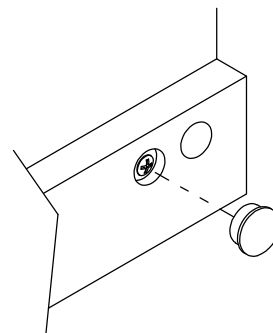
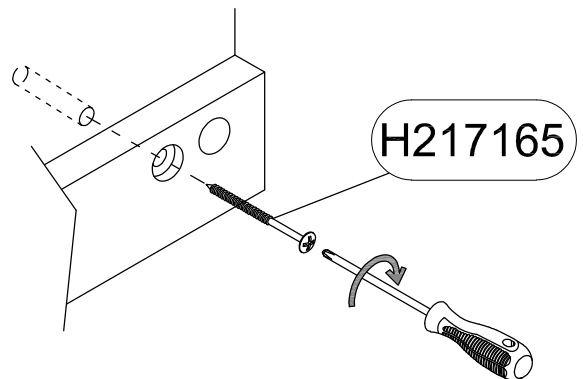
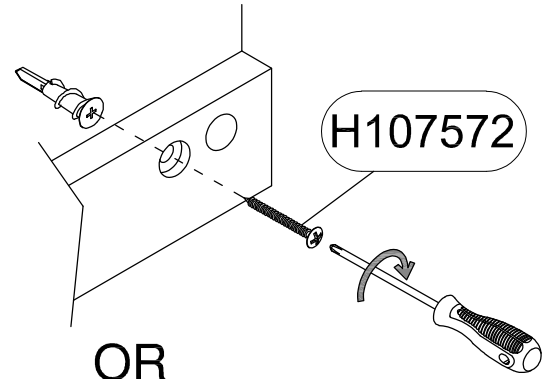
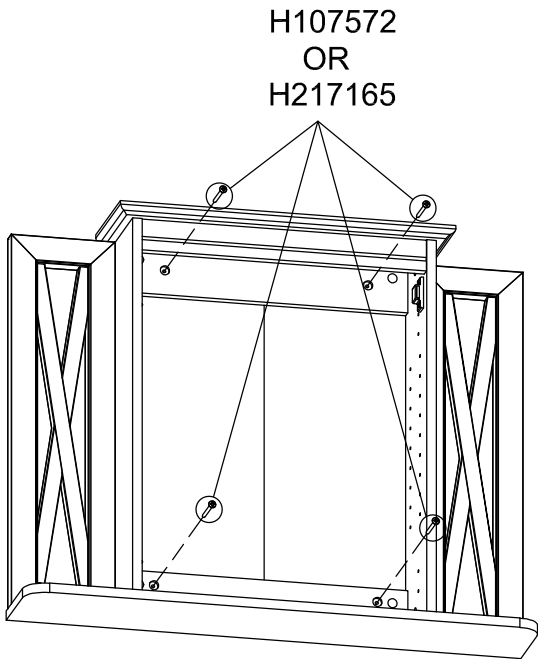

Have an assembly question or need a replacement part? Just call
1-800-950-4782, we are here to help.

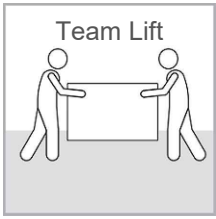

H23604

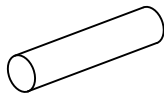

[8]

Shelf Pin
1" x 3/16"

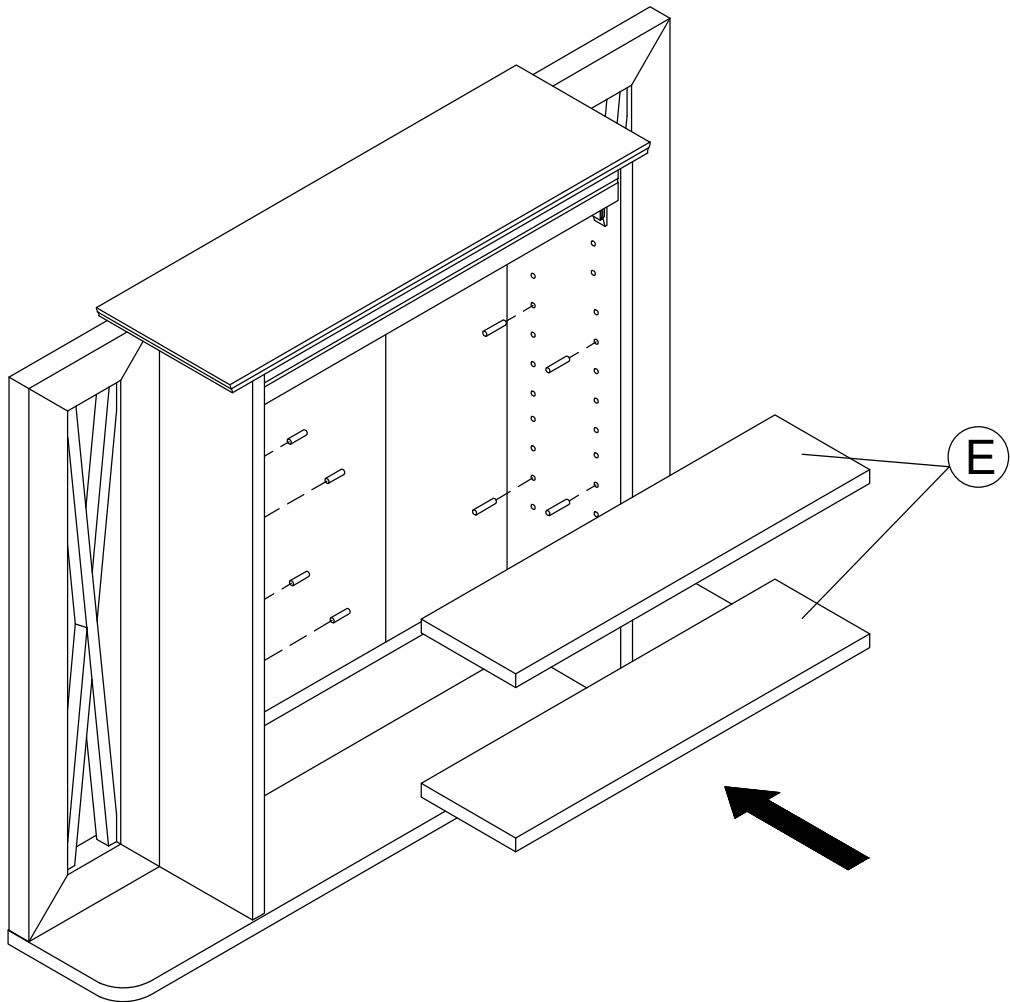

Have an assembly question or need a replacement part? Just call
1-800-950-4782, we are here to help.

Left Option

Go to step 29
Proceda al paso 29
Allez a l'etape 29

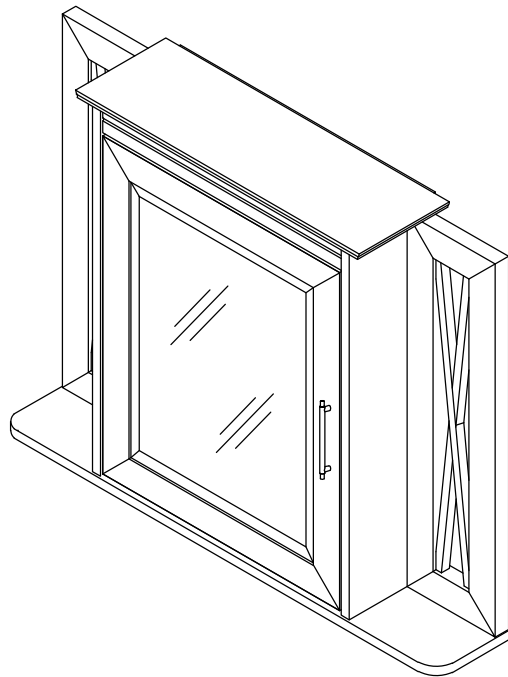

Right Option

Go to step 31
Proceda al paso 31
Allez a l'etape 31

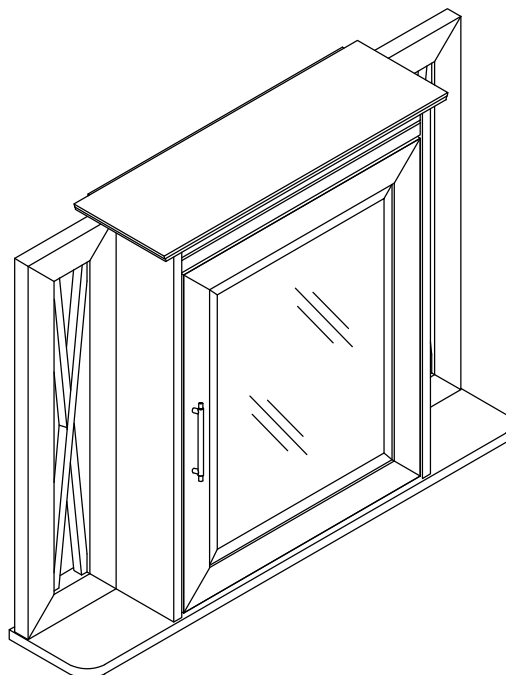

Have an assembly question or need a replacement part? Just call
1-800-950-4782, we are here to help.

STEP 29

Prepare Door

A217161

H170611

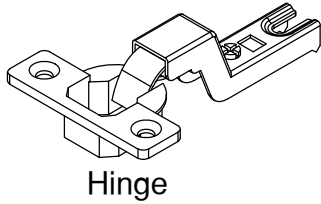

[2]

H153242

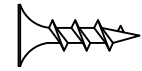

[4]

#8 x 5/8"

H158933



[2]

H180971

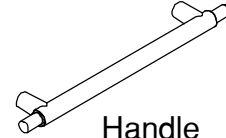

[1]

H124395



[1]

H217164



[1]

#6 x 1/2"

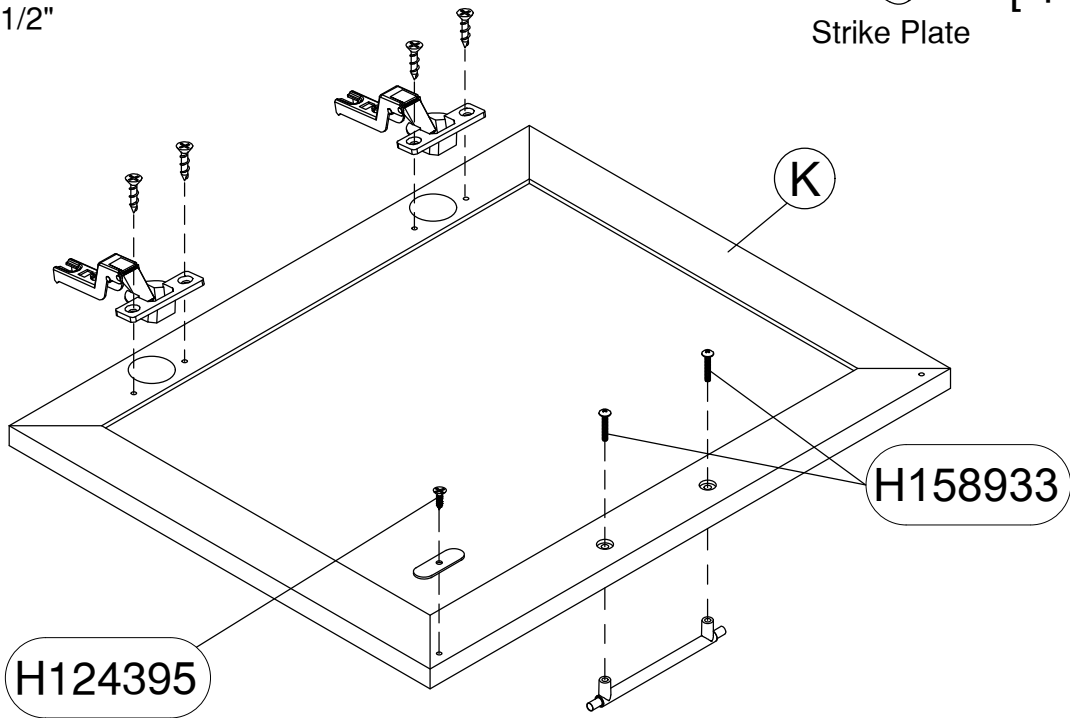
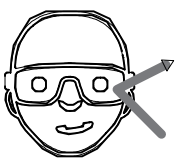
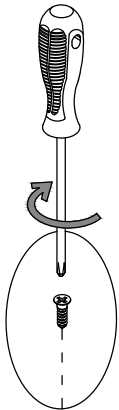

Safety glasses
Gafas de seguridad
Lunettes de protection



CAUTION



Risk of breaking glass. Handle glass carefully during assembly. Use eye and hand protection. Improper handling can result in cuts or lacerations.

Riesgo de romper el vidrio. Maneje el vidrio con cuidado al ensamblar esta unidad. Use protección para sus ojos y sus manos. El manejo inapropiado del vidrio puede causarle cortaduras o laceraciones.

Risque de bris de verre. Faites attention lors de la manipulation du verre pendant l'assemblage. Utilisez des protections pour les yeux et les mains. Une mauvaise manipulation peut provoquer des coupures ou des lacerations.

Have an assembly question or need a replacement part? Just call
1-800-950-4782, we are here to help.

Scan QR Code to Watch Video on:



How to Adjust Door Hinges

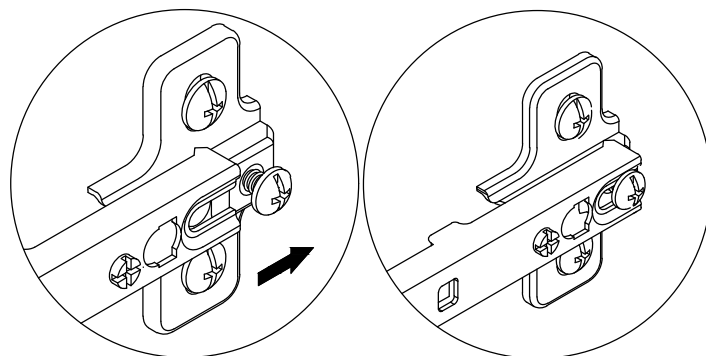
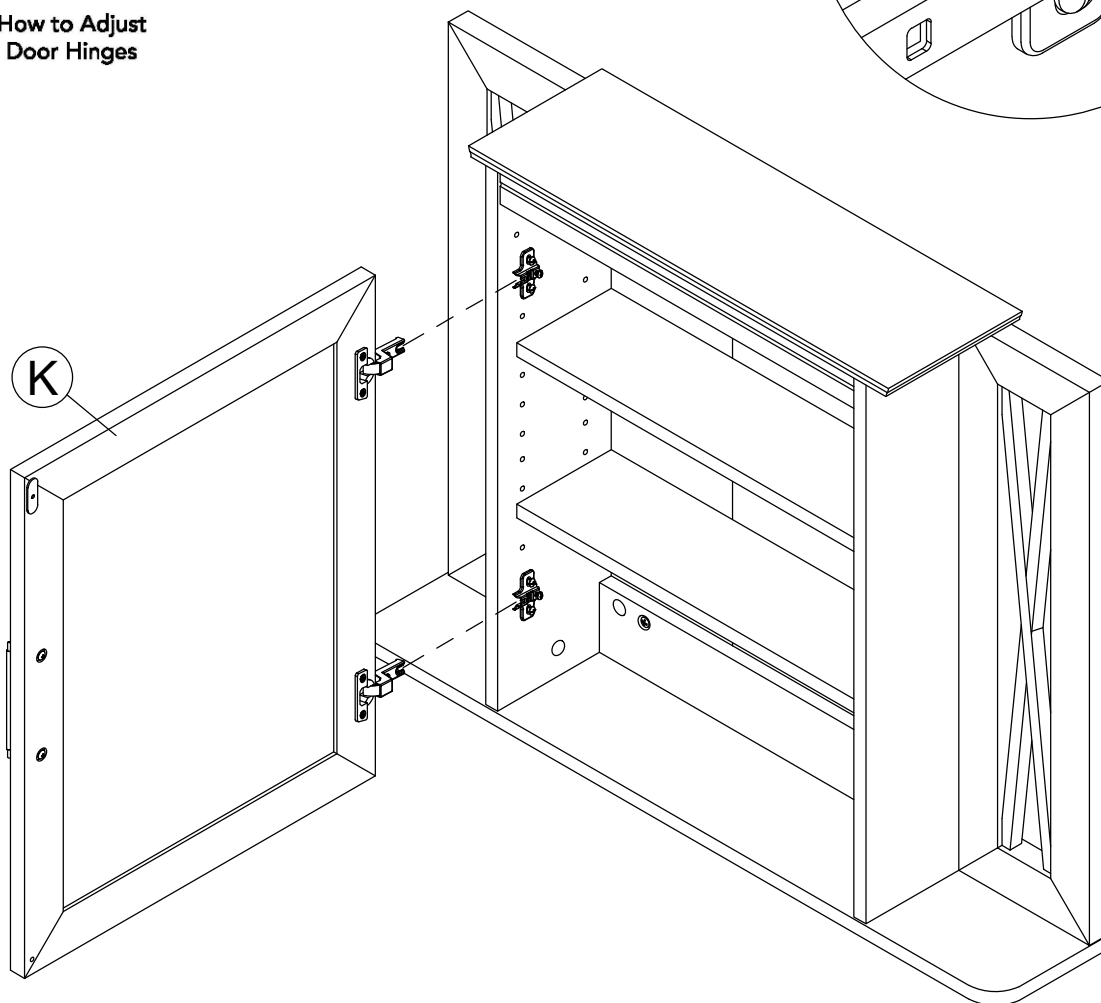
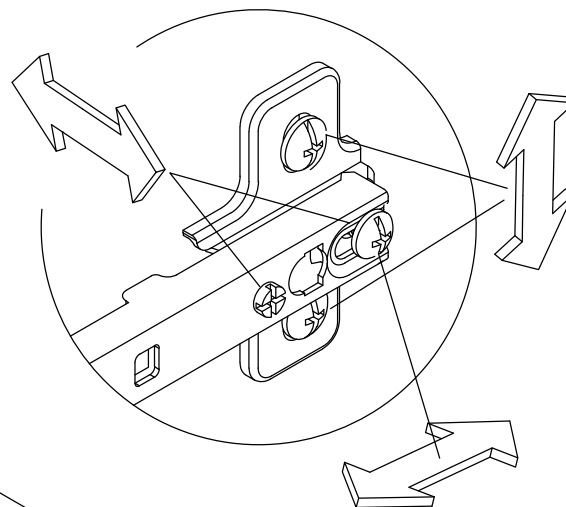

Have an assembly question or need a replacement part? Just call **1-800-950-4782**, we are here to help.

STEP 31

Prepare Door

A217161

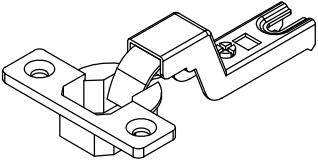
- H170611  [2]

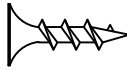
Hinge
- H153242  [4]

#8 x 5/8"
- H158933  [2]

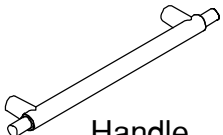
#8 x 3/4"
- H180971  [1]

Handle
- H124395  [1]

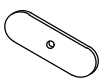
#6 x 1/2"
- H217164  [1]

Strike Plate

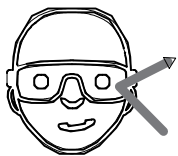
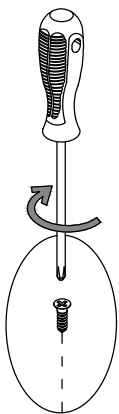

Safety glasses
Gafas de seguridad
Lunettes de protection

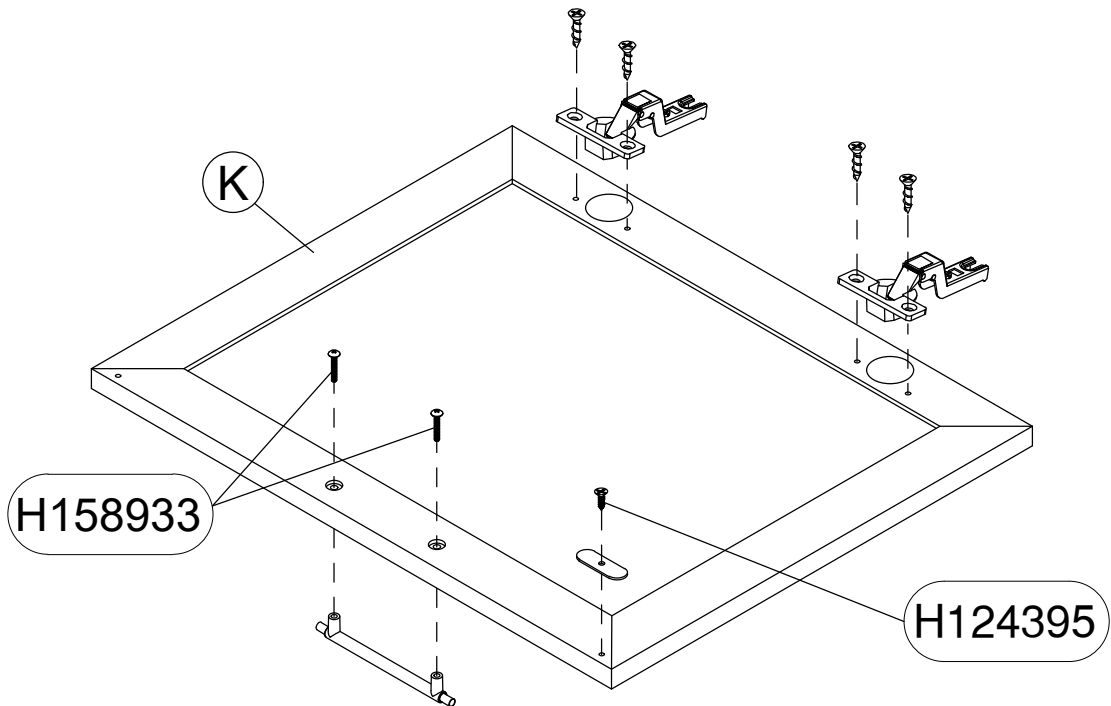

CAUTION



Risk of breaking glass. Handle glass carefully during assembly. Use eye and hand protection. Improper handling can result in cuts or lacerations.

Riesgo de romper el vidrio. Maneje el vidrio con cuidado al ensamblar esta unidad. Use protección para sus ojos y sus manos. El manejo inapropiado del vidrio puede causarle cortaduras o laceraciones.

Risque de bris de verre. Faites attention lors de la manipulation du verre pendant l'assemblage. Utilisez des protections pour les yeux et les mains. Une mauvaise manipulation peut provoquer des coupures ou des lacérations.

Have an assembly question or need a replacement part? Just call **1-800-950-4782**, we are here to help.

Scan QR Code to
Watch Video on:



How to Adjust
Door Hinges

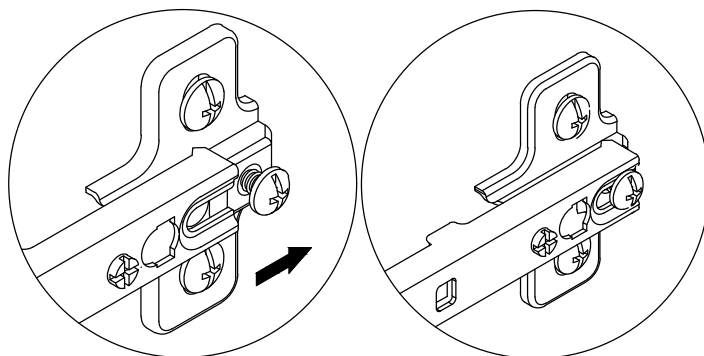
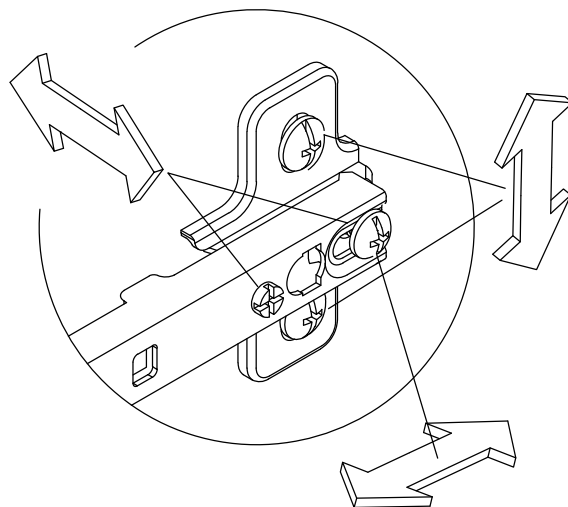
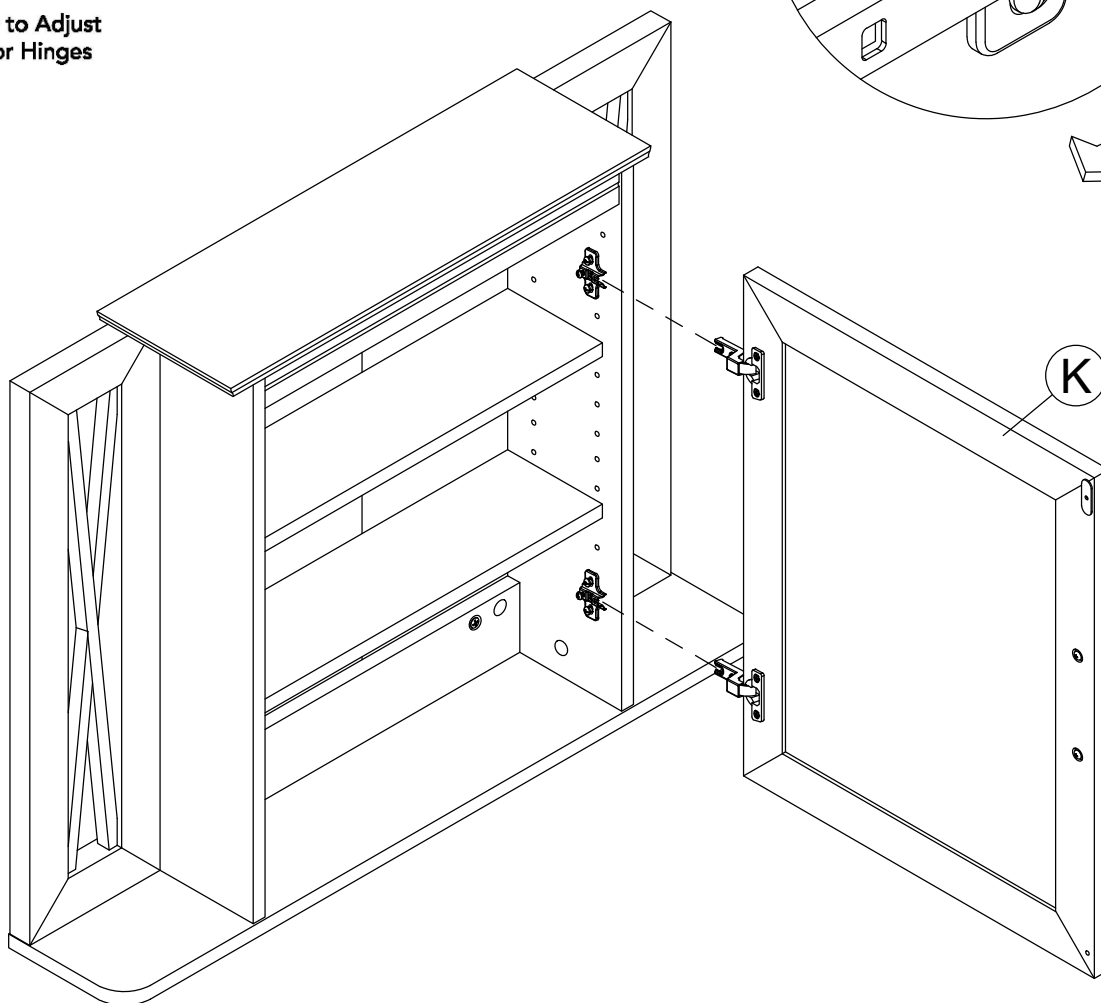

Have an assembly question or need a replacement part? Just call
1-800-950-4782, we are here to help.

Scan QR Code to
Watch Video on:



How to Clean
the Surface

Gently clean
surfaces with a damp
sponge eraser.

MAXIMUM WEIGHT: 0 LBS (0 KG)
PESO MÁXIMO: 0 LIBRAS (0 KILOGRAMO)
POIDS MAXIMUM: 0 LIVRES (0 KILOGRAMME)

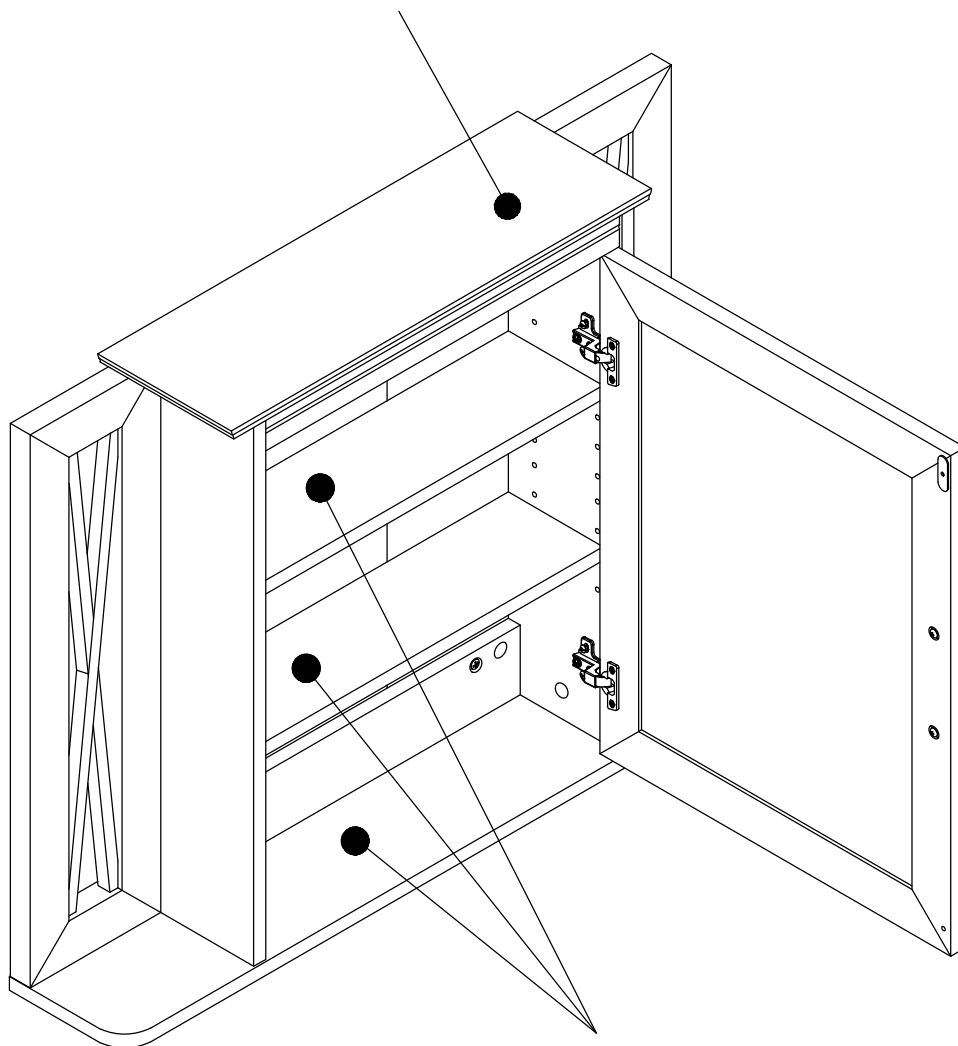

MAXIMUM WEIGHT: 5 LBS (2.27 KG)
PESO MÁXIMO: 5 LIBRAS (2.27 KILOGRAMO)
POIDS MAXIMUM: 5 LIVRES (2.27 KILOGRAMME)

Congratulations! You are all done. If you
have any questions or concerns, please call.

Have an assembly question or need a replacement part? Just call
1-800-950-4782, we are here to help.

KWWS132WAS

A	[1]	W 199638	G	[1]	S 199646
B	[1]	W 199639	H	[1]	S 199647
C	[1]	W 199640	I	[2]	W 199642
D	[1]	W 199648	J	[1]	S 199641
E	[2]	W 199643	K	[1]	S 217181
F	[1]	W 199644			

H192368



[10]

Cover Cap

H211643

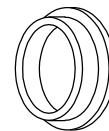

[10]

Hole Plug

KWWS132DG

A	[1]	W 199627	G	[1]	S 199635
B	[1]	W 199628	H	[1]	S 199636
C	[1]	W 199629	I	[2]	W 199631
D	[1]	W 199637	J	[1]	S 199630
E	[2]	W 199632	K	[1]	S 217182
F	[1]	W 199633			

H200206



[10]

Cover Cap

H208734

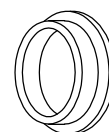

[10]

Hole Plug

Have an assembly question or need a replacement part? Just call
1-800-950-4782, we are here to help.

Scan QR Code to
Watch Video on:



Wall Mounted
Cabinet Attachment
to Wall Studs

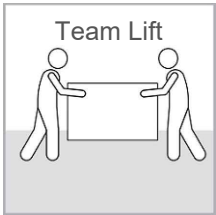

El gabinete está perforado previamente para el montaje en la pared y se puede fijar directamente a los montantes de pared de madera o una pared hueca. Es posible que deba utilizar tanto los montantes de pared como los anclajes de pared hueca que se proporcionan.

Procedimiento:

1. Coloque el gabinete en la ubicación final deseada.
2. Con un ayudante para mantener el gabinete en posición, verifique que esté nivelado.
3. Marque ligeramente la pared en la parte superior y lateral del gabinete.
4. Inserte el tornillo # 10 x 2.5 " (H217165) en los (4) orificios de montaje y presione firmemente o golpee ligeramente con un martillo para marcar la pared para perforar.
5. Ponga el gabinete a un lado

H217165

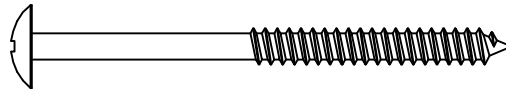

[4]

10 X 2.5 "

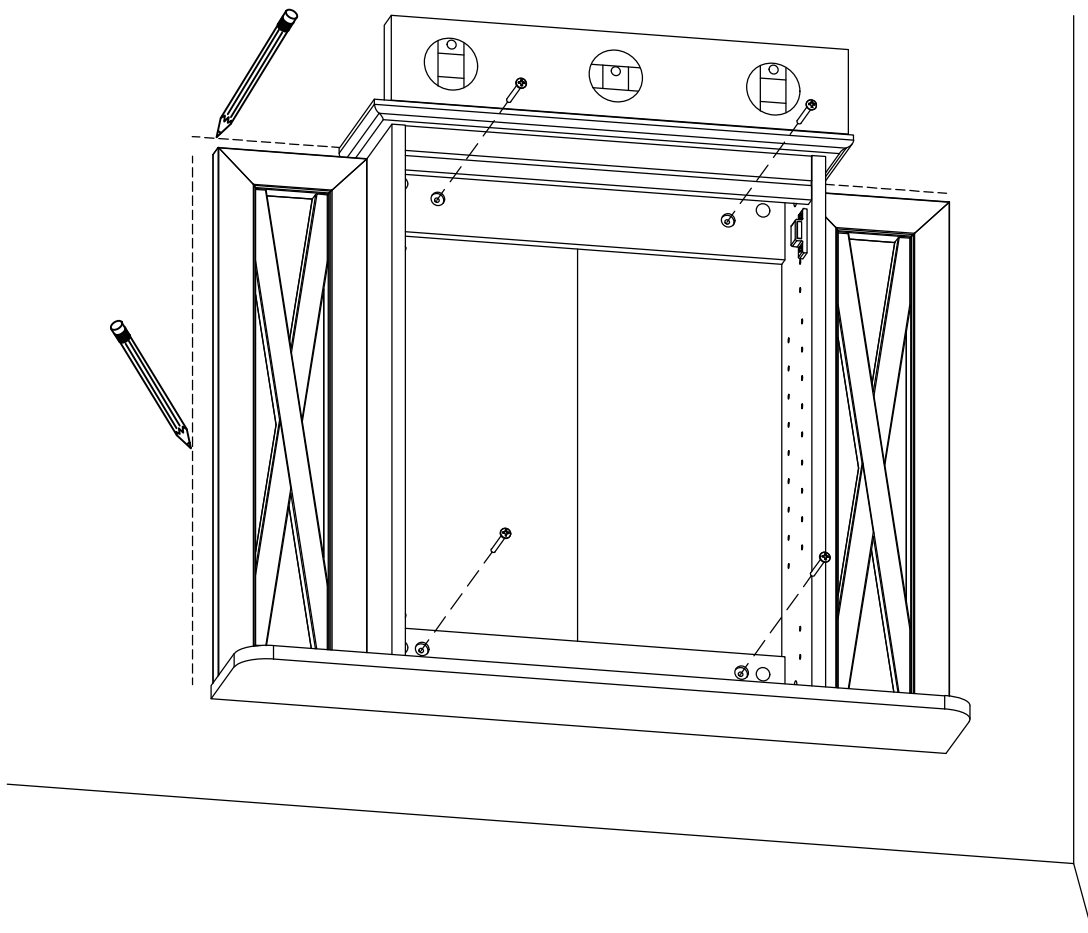

Have an assembly question or need a replacement part? Just call
1-800-950-4782, we are here to help.

NOTA: Puede haber tuberías o líneas eléctricas en las paredes de las viviendas residenciales. Se debe tener cuidado al perforar paredes. Si no está seguro de sus capacidades de instalación, consulte a un instalador profesional.

1. Marque la ubicación de los agujeros con un lápiz.
2. En las ubicaciones marcadas, taladre (4) orificios de 1/8" (3 mm) justo a través de la pared hueca de 1/2 a 3/4" (12-19 mm) de profundidad o 2" (50 mm) de profundidad si se encuentran montantes de madera.
3. Tome nota en el diagrama a continuación si se encuentra un montante de pared durante este paso. El anclaje de pared hueca H200009 debe instalarse en cualquier orificio donde no se encuentre el montante (consulte el paso 28). Puede haber situaciones en las que se utilicen tanto anclajes de pared huecos como anclajes de perno prisionero de tornillo largo.
4. Instale el anclaje de pared H200009 en los orificios donde no se encontró el montante de pared.

H200009

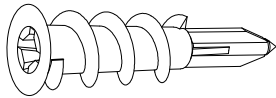

[4]

Wall Anchor

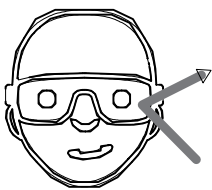

Safety glasses
Gafas de seguridad
Lunettes de protection

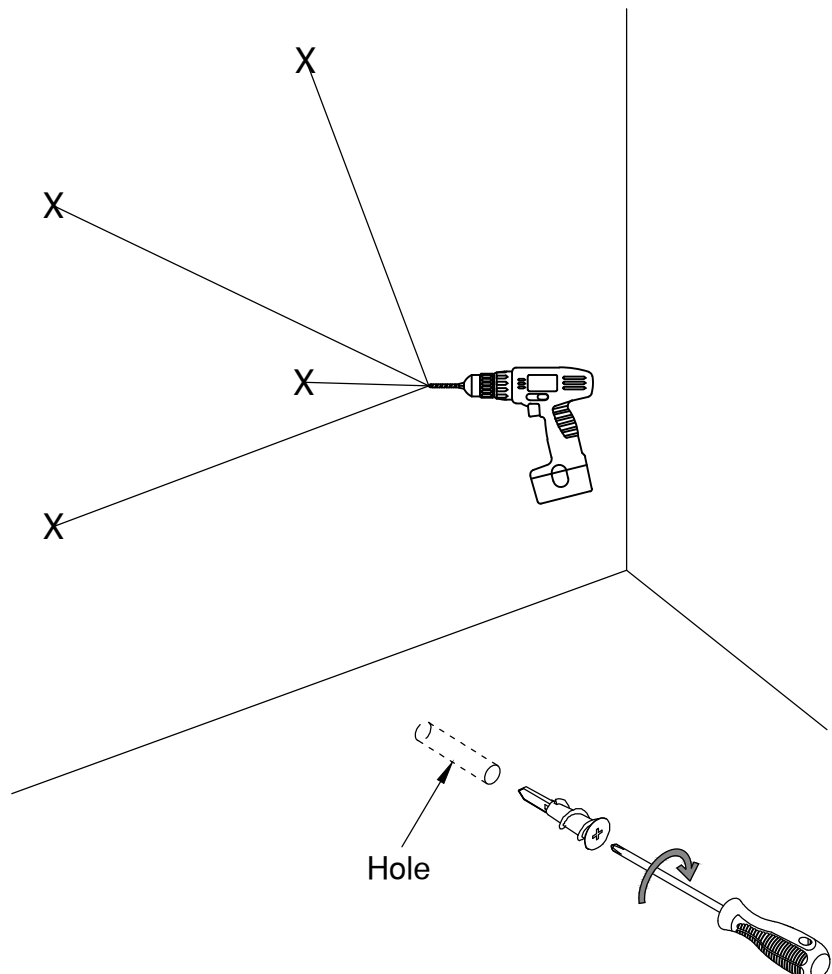

Have an assembly question or need a replacement part? Just call
1-800-950-4782, we are here to help.

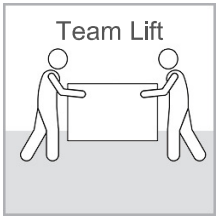

1. Con el asistente, alinee el gabinete con las marcas de lápiz del paso 26 y taladre orificios o anclajes de pared.
2. Usando el diagrama del paso 27, elija el tornillo H217165 para los agujeros en los montantes de la pared y el tornillo H107572 para fijarlo al anclaje de la pared.

H217165

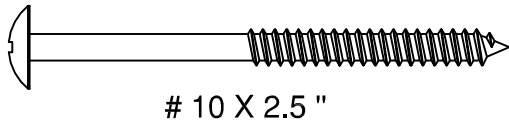

[4]

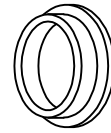

[4]

Hole Plug

H107572



[4]

#8x1-1/2"

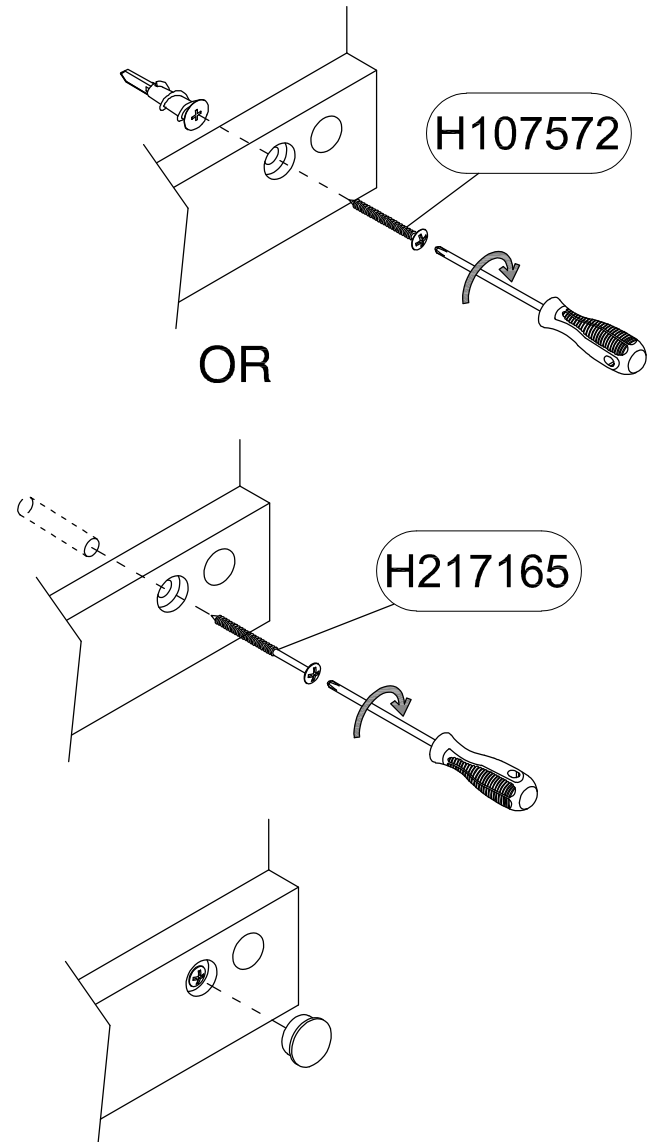
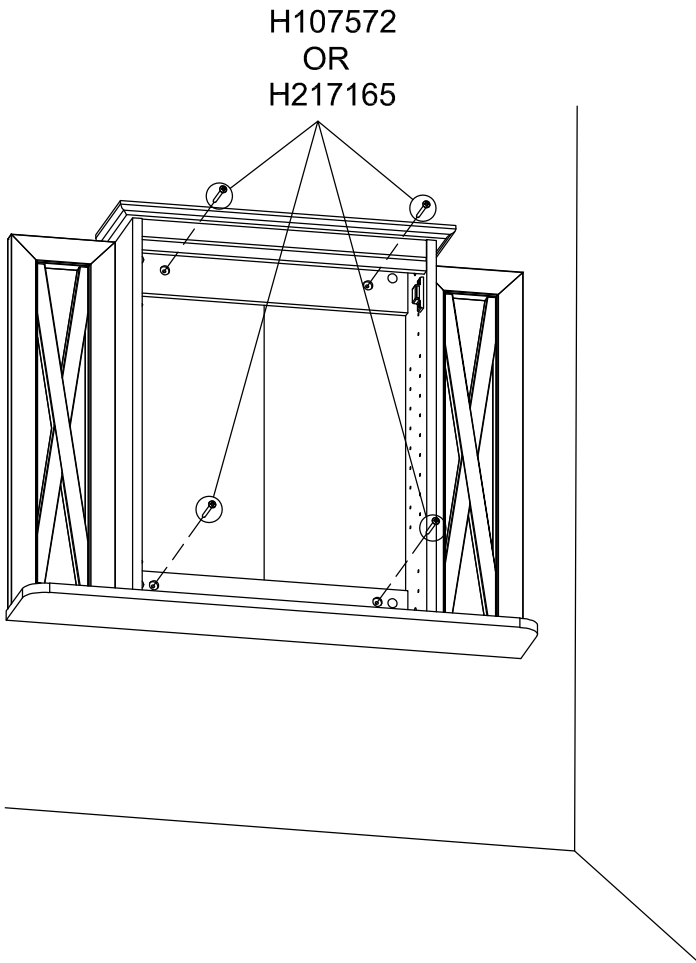

Have an assembly question or need a replacement part? Just call **1-800-950-4782**, we are here to help.

Scan QR Code to
Watch Video on:



Wall Mounted
Cabinet Attachment
to Wall Studs



L'armoire est pré-percée pour un montage mural et peut se fixer directement sur des montants muraux en bois ou un mur creux.

Vous devrez peut-être utiliser à la fois les chevilles murales et les ancrages pour murs creux fournis.

Procédure:

1. Placez l'armoire à l'emplacement final souhaité.
2. Avec une aide pour maintenir l'armoire en position, vérifiez qu'elle est de niveau.
3. Marquez légèrement le mur en haut et sur le côté de l'armoire.
4. Insérez la vis # 10 x 2,5 "(H217165) dans les (4) trous de montage et poussez fermement ou tapotez légèrement avec un marteau pour marquer le mur pour le perçage.
5. Mettez l'armoire de côté

H217165

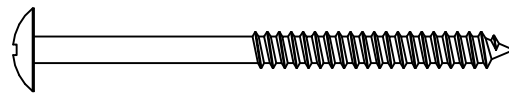

[4]

10 X 2.5 "

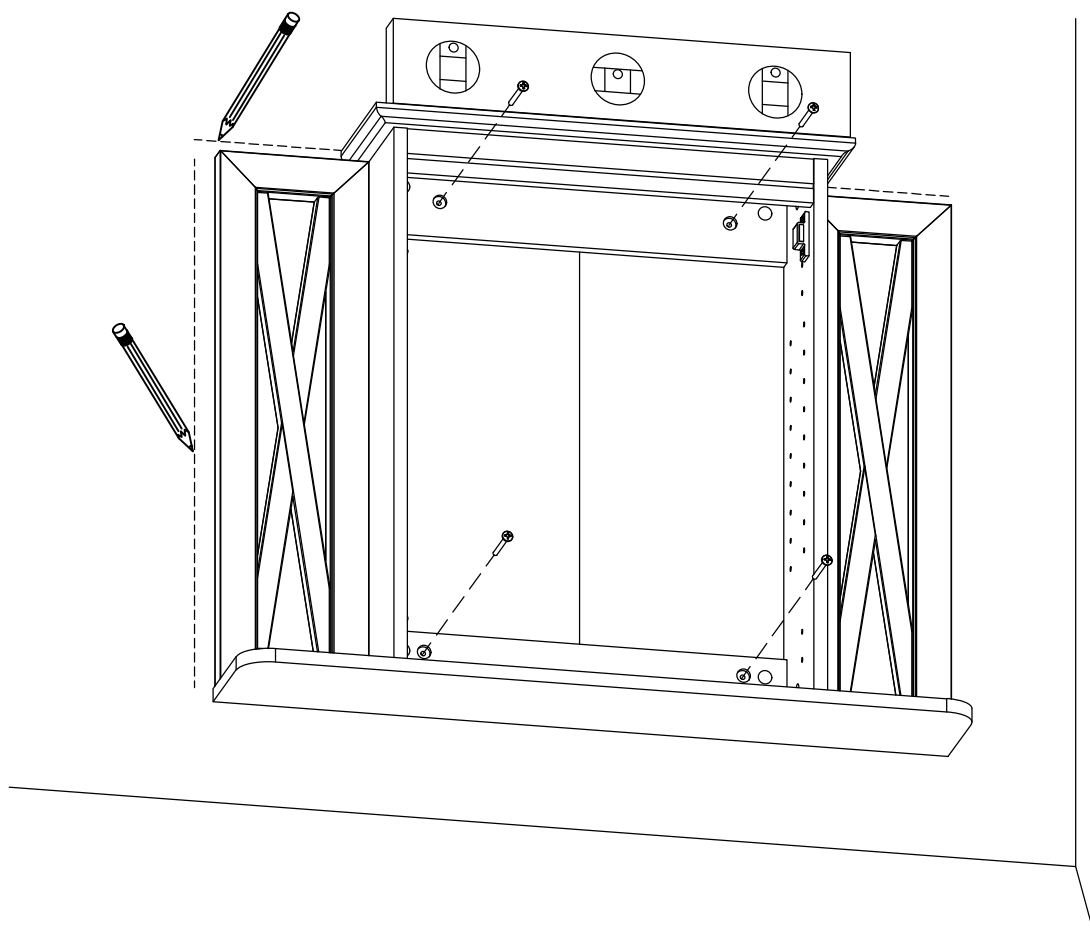

Have an assembly question or need a replacement part? Just call
1-800-950-4782, we are here to help.

REMARQUE: Il peut y avoir de la plomberie ou des lignes électriques dans les murs des habitations résidentielles. Des précautions doivent être prises lors du perçage dans les murs. Si vous n'êtes pas sûr de vos capacités d'installation, veuillez consulter un professionnel de l'installation.

1. marquez les emplacements des trous avec un crayon.
2. Aux endroits marqués, percez (4) trous de 1/8 "(3 mm) juste à travers le mur creux de 1/2 à 3/4" (12-19 mm) de profondeur ou 2 "(50 mm) de profondeur si un montant de bois est rencontré.
3. Notez sur le schéma ci-dessous si un montant mural est rencontré pendant cette étape. L'ancrage pour mur creux H200009 doit être installé dans tout trou où aucun montant n'a été rencontré (voir l'étape 31). Il peut y avoir des situations où des ancrages de mur creux et des ancrages de goujon à vis longues sont utilisés.
4. Installez l'ancrage mural H200009 dans les trous où le montant du mur n'a pas été trouvé.

H200009

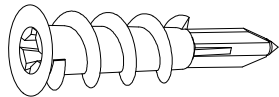

[4]

Wall Anchor

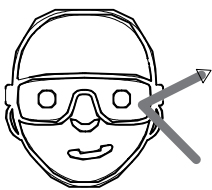

Safety glasses
Gafas de seguridad
Lunettes de protection

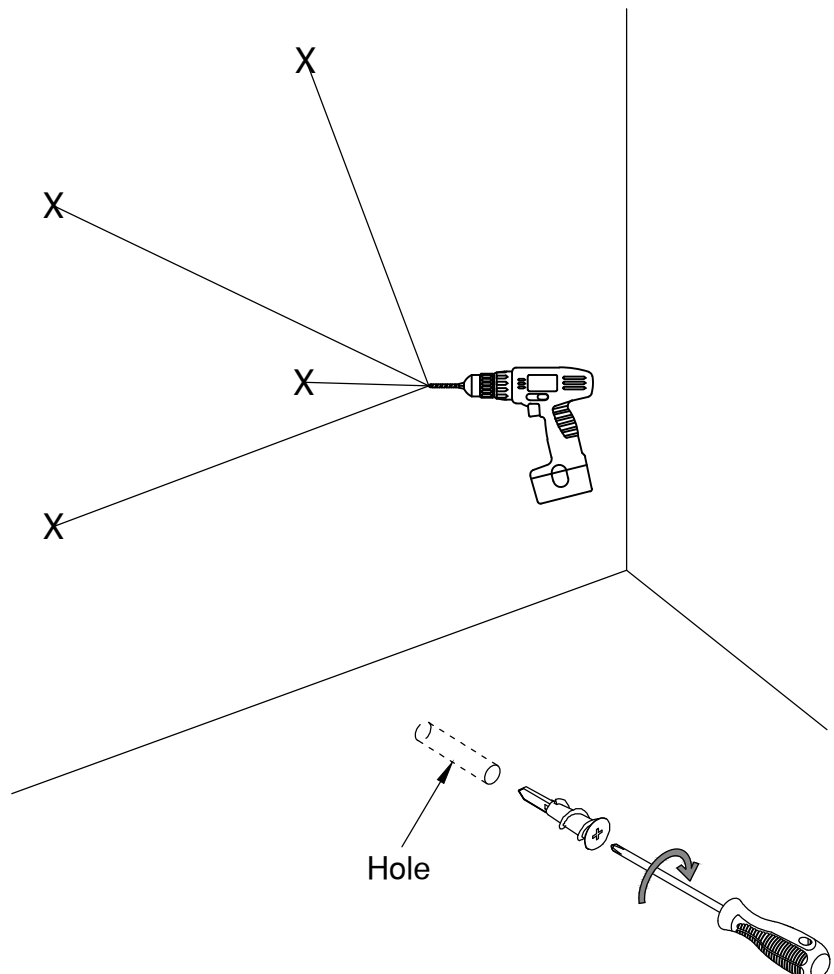

Have an assembly question or need a replacement part? Just call
1-800-950-4782, we are here to help.

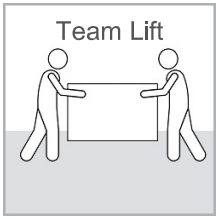

1. Avec l'assistant, alignez l'armoire avec les marques de crayon de l'étape 29 et percez des trous ou des ancrages muraux.
2. À l'aide du diagramme de l'étape 32, choisissez la vis H217165 pour les trous dans les montants muraux et la vis H107572 pour la fixation à l'ancrage mural.

H217165

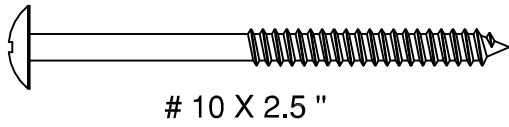

[4]

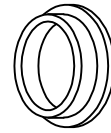

[4]

Hole Plug

H107572

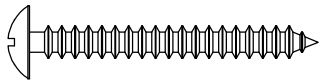

[4]

#8x1-1/2"

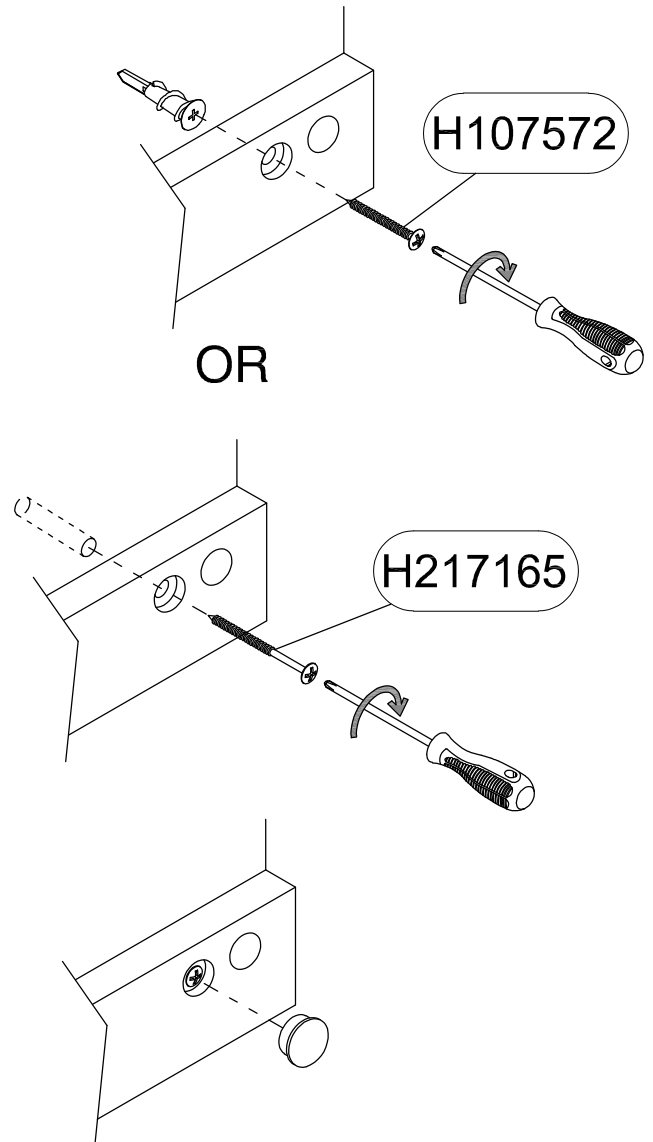
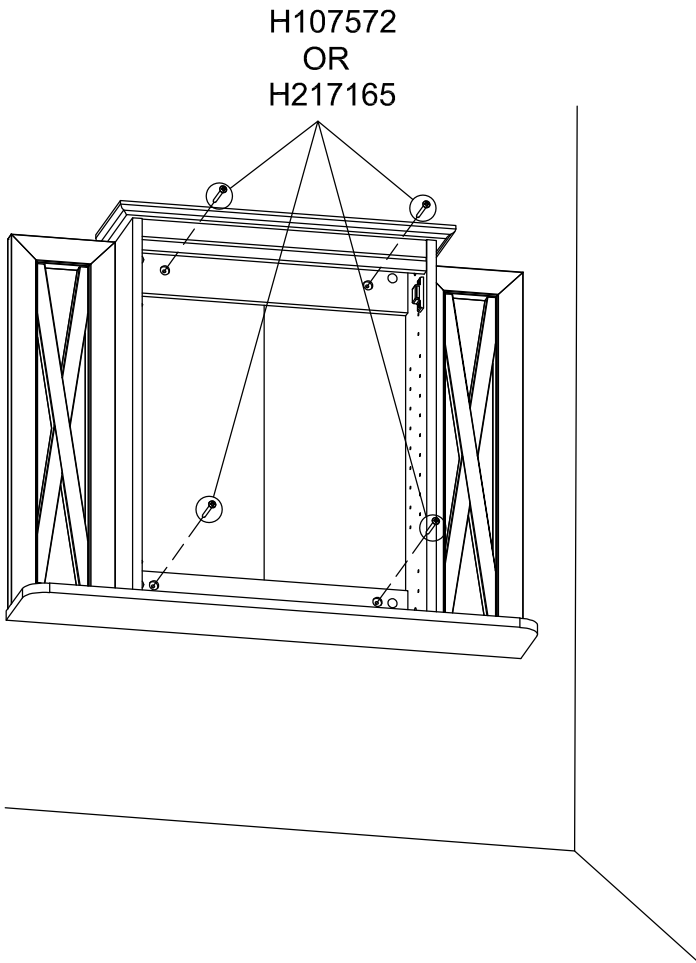

Have an assembly question or need a replacement part? Just call
1-800-950-4782, we are here to help.

THIS PAGE INTENTIONALLY LEFT BLANK

THIS PAGE INTENTIONALLY LEFT BLANK

WARRANTY INFORMATION/INFORMATIONS POUR LA GARANTIE/INFORMACIÓN DE GARANTÍA

BUSH FURNITURE'S WRITTEN WARRANTY TO YOU

In order to provide you with timely assistance, please thoroughly inspect your furniture for missing or defective parts immediately after opening the carton. To receive replacement or missing parts under this warranty, call our Consumer Service Department TOLL-FREE at 1-800-950-4782. Please have the Model, Part, and Lot Numbers found in the instruction manual available for your reference. You will also need your sales receipt or other proof of purchase. Replacement part(s) will be shipped to you at no charge with Bush Industries assuming all shipping and handling charges.

This Bush Furniture product is warranted to the original purchaser at the time of purchase and for a period of one year thereafter.

We warrant to you, the original purchaser, that our furniture and all its parts and components are free of defects in material or workmanship. "Defects," as used in this warranty, is defined as any imperfection which impairs the use of the furniture product.

Our warranty is expressly limited to the replacement of furniture parts and components. For one year after the date of purchase, Bush will replace any parts that are defective in material or workmanship.

This warranty applies under conditions of normal use. Our Bush Furniture products are not intended for outdoor use. This warranty does not cover: 1) defects caused by improper assembly or disassembly; 2) defects occurring after purchase due to product modification, intentional damage, accident, misuse, abuse, negligence or exposure to the elements; and 3) labor or assembly costs. 4) batteries are not included.

IMPLIED WARRANTIES, INCLUDING THE WARRANTY OF MERCHANTABILITY, SHALL NOT EXTEND BEYOND THE DURATION OF THE WRITTEN WARRANTY STATED ABOVE, AND IN NO EVENT SHALL BUSH BE LIABLE FOR INCIDENTAL OR CONSEQUENTIAL DAMAGES RESULTING FROM USE OF THE PRODUCT.

Some states do not allow a limitation on how long an implied warranty lasts or the exclusion or limitation of incidental or consequential damages, so the above limitation and exclusion may not apply to you.

This warranty gives you specific legal rights. You may also have other rights that may vary from state to state.

VOTRE GARANTIE BUSH FURNITURE

Afin de vous assister rapidement, veuillez inspecter votre mobilier en détail immédiatement après l'ouverture du carton en cas de pièces manquantes ou défectueuses. Pour recevoir une pièce de rechange ou manquante couverte par cette garantie, appelez notre département de service clientèle GRATUITEMENT au 1-800-950-4782. Veuillez tenir à disposition les numéros de modèle, de pièce et de lot qui se trouvent dans le manuel d'instruction pour votre référence. Vous aurez également besoin de votre reçu ou d'une autre preuve d'achat. La (les) pièce(s) de rechange vous sera (seront) envoyée(s) sans frais, Bush Industries se chargeant de tous les frais d'expédition.

Tout le produit Bush Furniture est garanti à l'acheteur original à partir de la date d'achat pour une période d'un an.

Nous vous garantissons, à vous l'acheteur original, que notre mobilier et toutes ses pièces et composants sont sans défaut de matériau ou de fabrication. Le terme "défauts" utilisé dans cette garantie, est défini comme étant toutes les imperfections qui compromettent l'utilisation du meuble.

Notre garantie est expressément limitée au remplacement des pièces et des composants du mobilier. Pendant un an après la date d'achat, Bush remplacera toute pièce défectueuse dans le matériau ou sa fabrication.

Cette garantie d'applique sous des conditions d'utilisation normale. Nos produits ne sont pas destinés à être utilisés en plein air. Cette garantie ne couvre pas: 1) les défauts causés par un mauvais assemblage ou démontage, 2) les défauts ayant lieu après l'achat et dus à la modification du produit, des dommages intentionnels, des accidents, une mauvaise utilisation, un mauvais traitement, la négligence ou l'exposition aux éléments, et 3) les frais de main d'œuvre ou d'assemblage. 4) les piles ne sont pas incluses.

LES GARANTIES TACITES, Y COMPRIS LA GARANTIE DE QUALITE MARCHANDE, NE S'ETENDRONT PAS AU-DELA DE LA DUREE ECRITE CITEE CI-DESSUS, ET BUSH NE SERA EN AUCUN CAS RESPONSABLE DES DOMMAGES ACCESSOIRES OU INDIRECTS RESULTANT DE L'UTILISATION DU PRODUIT. Certains états ne permettent pas d'appliquer une limite à la durée de la garantie tacite, ni une exclusion ou limitation des dommages accessoires ou indirects; dans ce cas les limitations ou exclusion ci-dessus peuvent ne pas s'appliquer à vous.

Cette garantie vous donne des droits légaux spécifiques. Il se peut que vous ayez également d'autres droits qui peuvent varier d'un état à l'autre.

GARANTIA ESCRITA DE BUSH FURNITURE PARA USTED

Para brindarle asistencia oportuna, por favor, verifique detalladamente que a su mueble no le falte o tenga piezas defectuosas inmediatamente después de abrir la caja. Para recibir un reemplazo o la parte faltante bajo esta garantía, llame a nuestro Departamento de Servicio al Consumidor GRATIS al 1-800-950-4782. Sírvase traer los números de modelo, parte y lote que se encuentran en el manual de instrucciones disponible para su referencia. Además, necesitará el recibo de su compra u otra prueba de compra. La(s) pieza(s) de reemplazo le será(n) enviada(s) sin recargo por Bush Industries asumiendo los gastos de envío y manipuleo.

Todo mueble de Bush Furniture es garantizado al comprador original al momento de la compra y por un periodo de uno año en adelante.

Le garantizamos a usted, el comprador original, que nuestros muebles sus partes y componentes están libres de defectos en materiales o trabajo. "Defectos", según se usa en esta garantía, se define como una imperfección que perjudica el uso del producto mobiliario.

Nuestra garantía se limita expresamente al reemplazo de partes y componentes mobiliarios. Durante uno año después de la fecha de compra, Bush reemplazará cualquier parte defectuosa en material o trabajo.

Esta garantía se aplica bajo condiciones de uso normal. Nuestros productos de Bush Furniture no son para uso en exteriores. Esta garantía no cubre: 1) defectos causados por un ensamblaje o desensamblaje inadecuado; 2) defectos que ocurran después de la compra debido a modificación del producto, daño intencional, accidente, mal uso, abuso, negligencia o exposición a los elementos; y 3) costos de trabajo o ensamblaje. 4) las baterías no están incluidas.

LAS GARANTÍAS IMPLICADAS, INCLUYENDO LA GARANTÍA DE COMERCIABILIDAD, NO SE EXTENDERÁN MÁS ALLÁ DE LA DURACIÓN DE LA GARANTÍA ESCRITA MENCIONADA, Y EN NINGÚN CASO BUSH SERÁ RESPONSABLE POR DAÑOS INCIDENTALES O CONSIGUIENTES COMO RESULTADO DEL USO DEL PRODUCTO. Algunos estados no permiten una limitación sobre el tiempo de duración de la garantía implicada o la exclusión o limitación de daños incidentales o consiguientes, de manera que la limitación y exclusión mencionadas pueden no aplicarse para usted.

Esta garantía le otorga derechos legales específicos. Puede también tener otros derechos que pueden variar según los estados.

1-Year
Manufacturer's
Warranty

Register your product online:

Scan the QR Code or go to
[https://bushfurniture.com/
activate-warranty/](https://bushfurniture.com/activate-warranty/)



Assembly tips & how to videos:

Scan the QR Code to access our video
guides [https://bushfurniture.com/
help-faq/#assembling](https://bushfurniture.com/help-faq/#assembling)

