



PROTOCOL™

SAW40

40" / 1000 LB CAPACITY LIGHTWEIGHT ALUMINUM FIXED LEG SAWHORSE

PRODUCT MANUAL

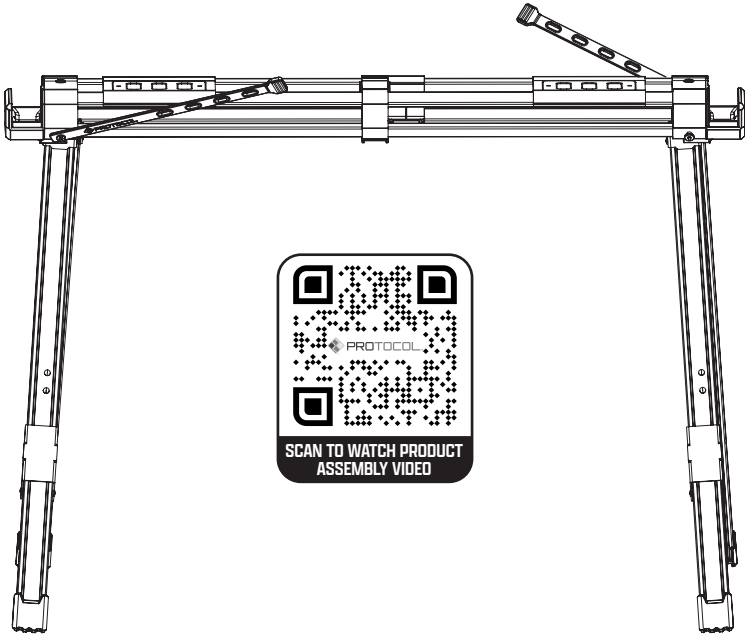

⚠ CAUTION: To reduce the risk of injury, user must read and understand this product manual. Save these instructions for future reference.

PROTOCOLEQUIPMENT.COM

TABLE OF CONTENTS

Features and Specifications	3
Preparing the Sawhorse.....	4-5
Mounting Workpiece or Sacrificial Wood.....	6
Constructing a Jobsite Table	7
Storing the Sawhorse.....	8-9
Safety and Warnings.....	10
General Maintenance.....	10
Warranty	11

⚠ WARNING: Be sure to read and understand all safety instructions in this manual, including all safety alert symbols such as “DANGER”, “WARNING”, “CAUTION”, and “IMPORTANT” before using this product. Failure to follow all instructions listed in the manual may result in electric shock, fire and/or serious personal injury.

FEATURES AND SPECIFICATIONS

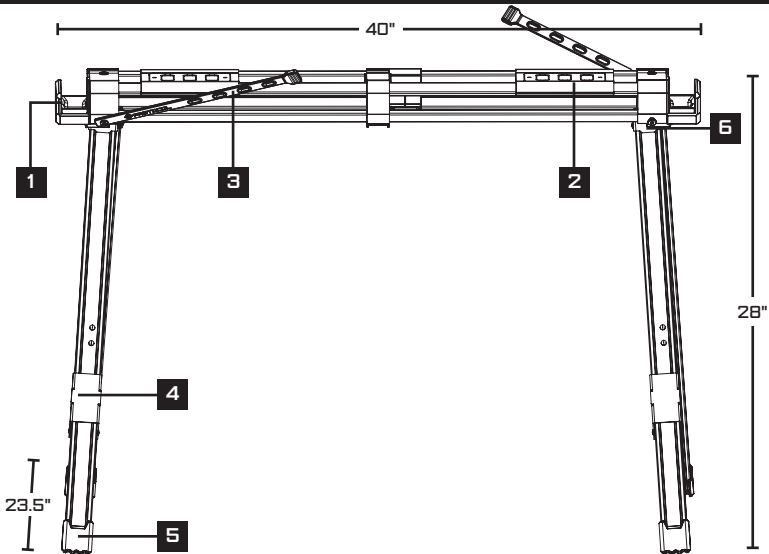

SPECIFICATIONS

HEIGHT	28"
WIDTH	40"
DEPTH	23.5"
MAX WEIGHT CAPACITY	1000 lb.
MATERIAL	Aluminum, Steel, Nylon
PRODUCT WEIGHT	14.2 lb.

INCLUDED FEATURES

1	2" X 4" Support arms
2	Saddle trays
3	Multipurpose straps
4	Fold out material support brackets
5	Folding legs with non-marring feet
6	Built-in stacking tabs

PREPARING THE SAWHORSE

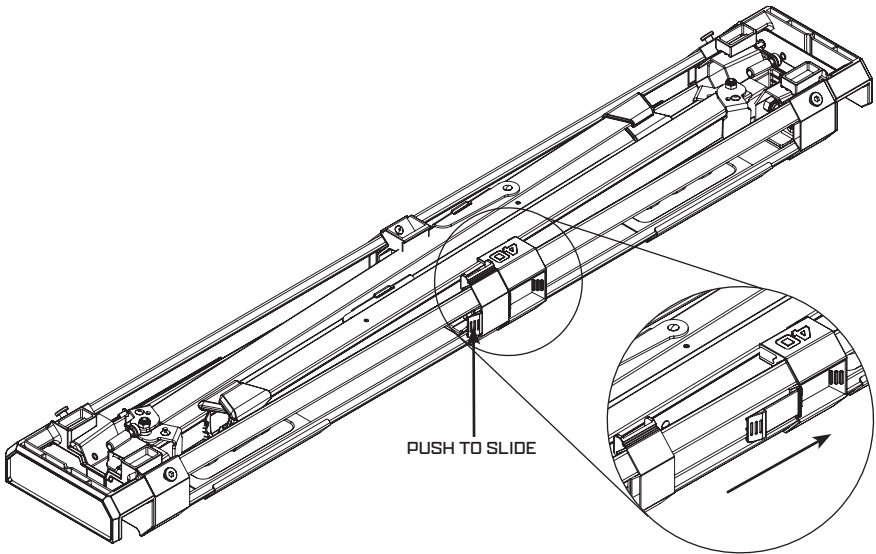

1. Place sawhorse on a flat and level surface with folded legs facing up.
2. Push to slide leg lock and unfold first set of legs from chassis.

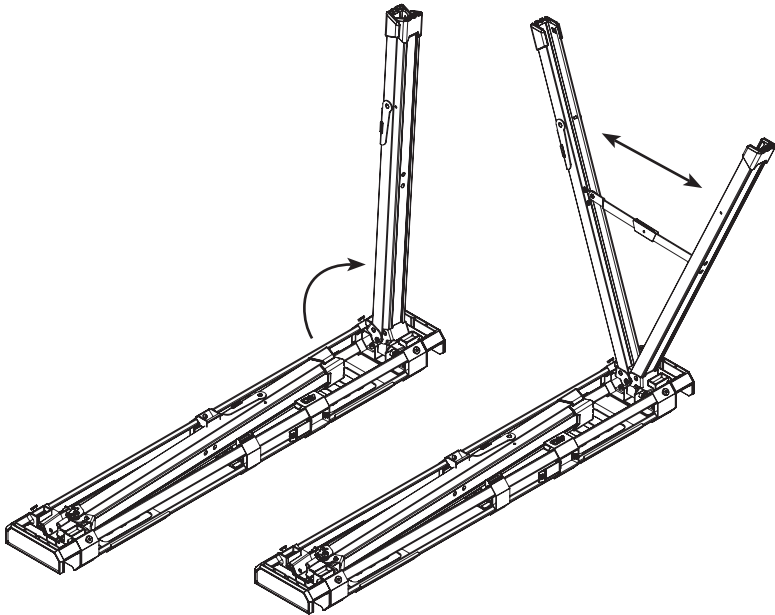

3. Deploy first set of legs. Make sure cross brace is secured in place to ensure legs are fully opened.
4. Unfold second set of legs and follow step #3.

PREPARING THE SAWHORSE

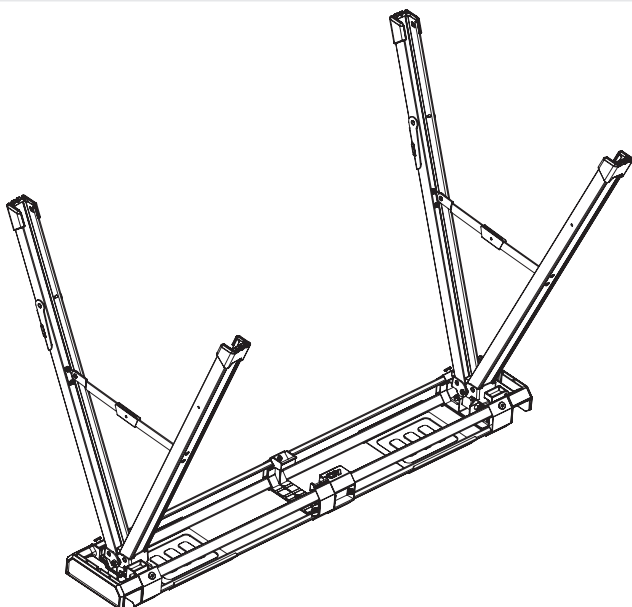

5. After both sets of legs are deployed, lift sawhorse in an upright position.

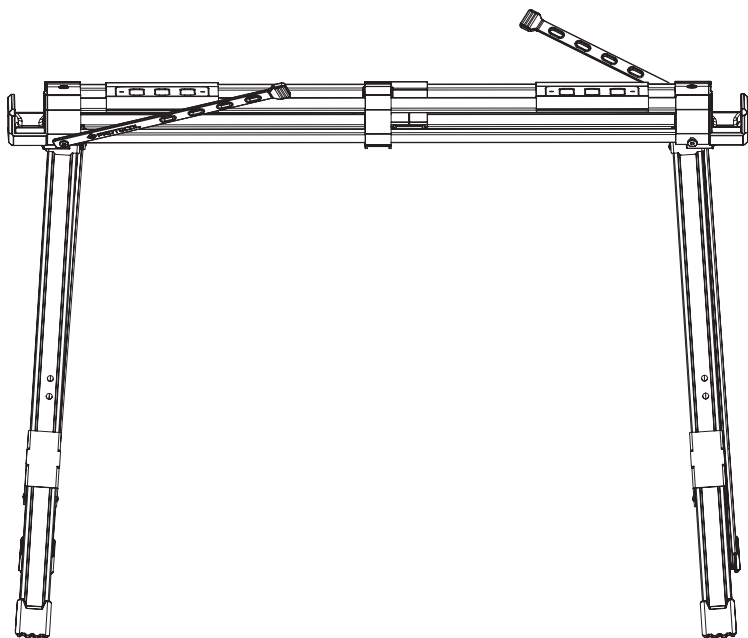

6. Ensure sawhorse is stable and both sets of legs are fully opened.

MOUNTING WORKPIECE OR SACRIFICIAL WOOD

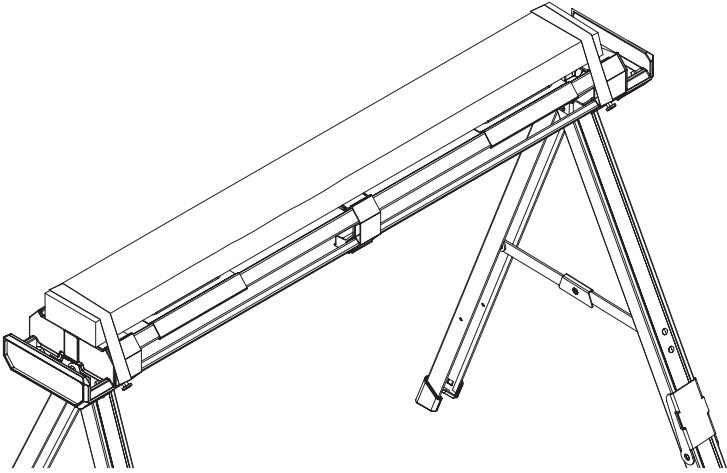

1. Place workpiece or 2" X 4" lumber on top of chassis.
2. Rubber straps are located on both ends of sawhorse. Pull each strap over material and secure strap to knob.

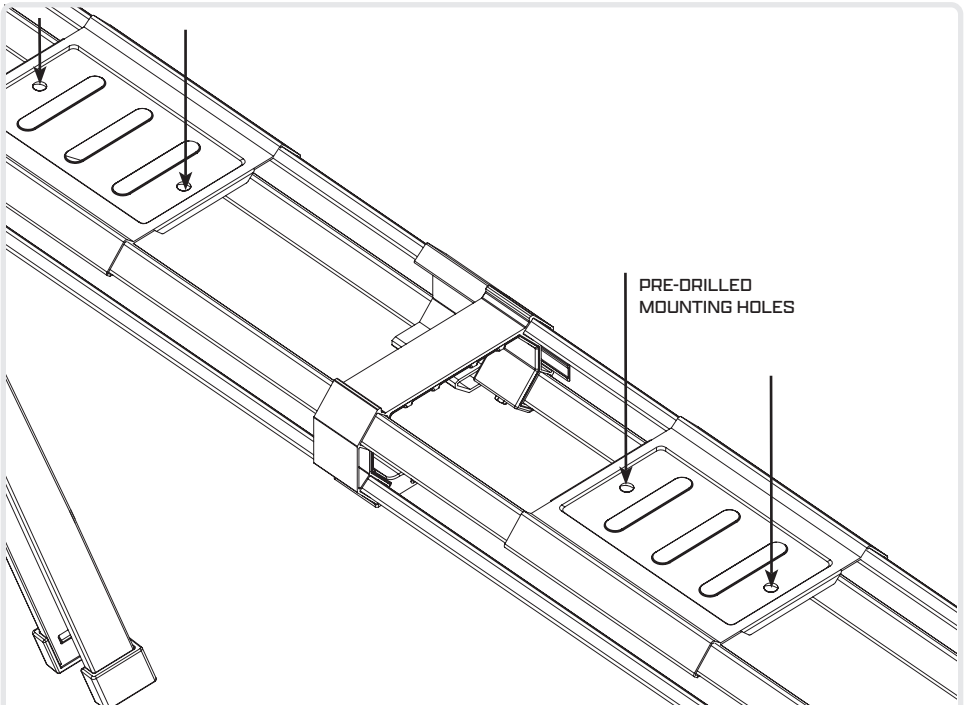

NOTE: Pre-drilled mounting holes on saddle trays can also be used to attach sacrificial wood.

CONSTRUCTING A JOBSITE TABLE

Materials Required: [2] SAW40, [4] 2" X 4" Lumber, [1] Plywood sheet

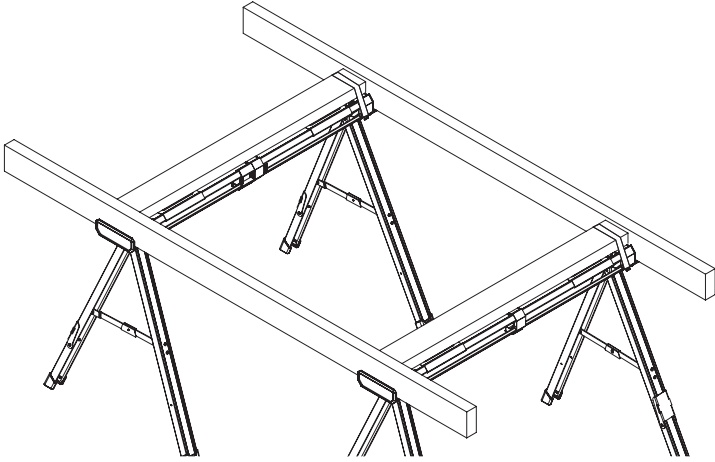

1. Place 2" X 4" lumber on top of each chassis.
2. Rubber straps are located on both ends of sawhorses. Pull each strap over material and secure strap to knob.
3. Place 2" X 4" lumber in support arms to connect sawhorse units.

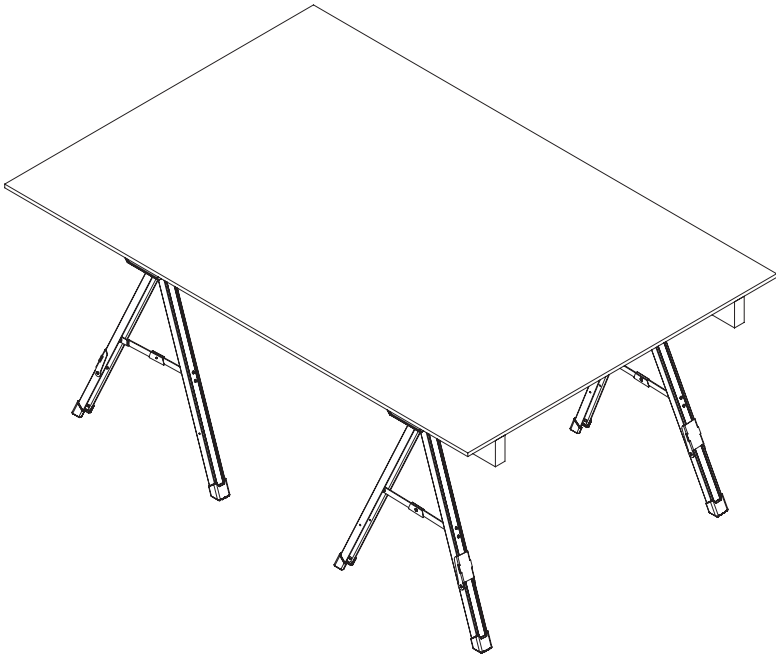

4. Place sheet on top of sawhorses to create a workspace.

STORING THE SAWHORSE

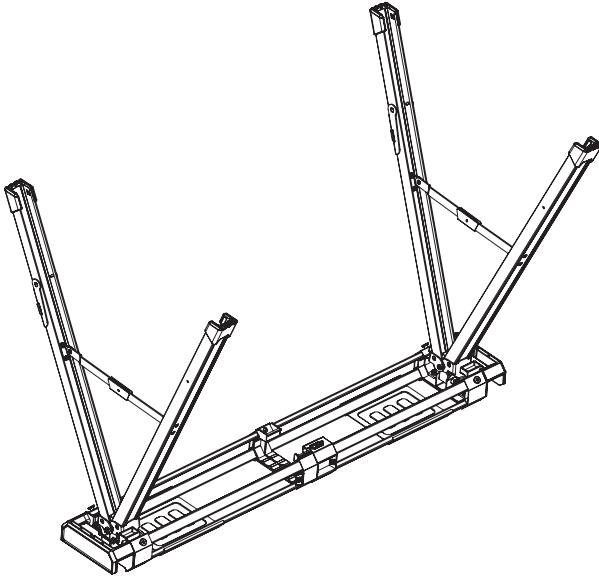

1. Carefully flip sawhorse over so that legs are facing up.

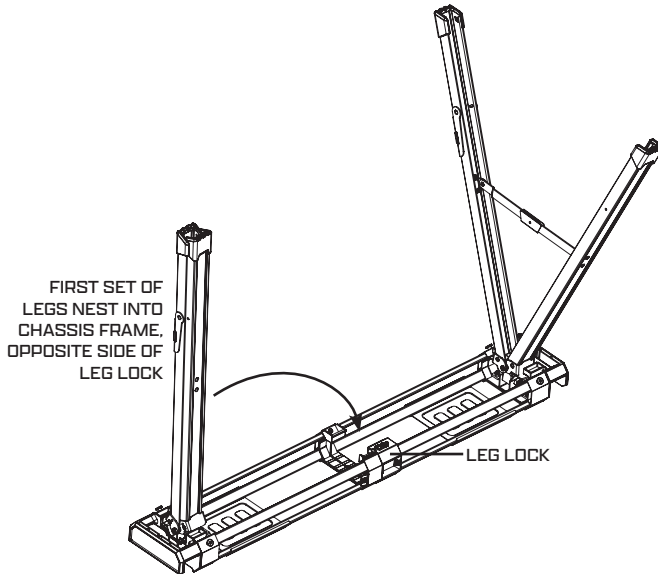

2. Set of legs opposite from leg lock must be folded into chassis first.
3. Press on cross brace to bring legs together. Push legs down until fully nested into chassis frame, opposite side of leg lock.
4. Repeat Step #4 to fold second set of legs. Push legs down until fully nested into chassis frame, same side as leg lock.

STORING THE SAWHORSE

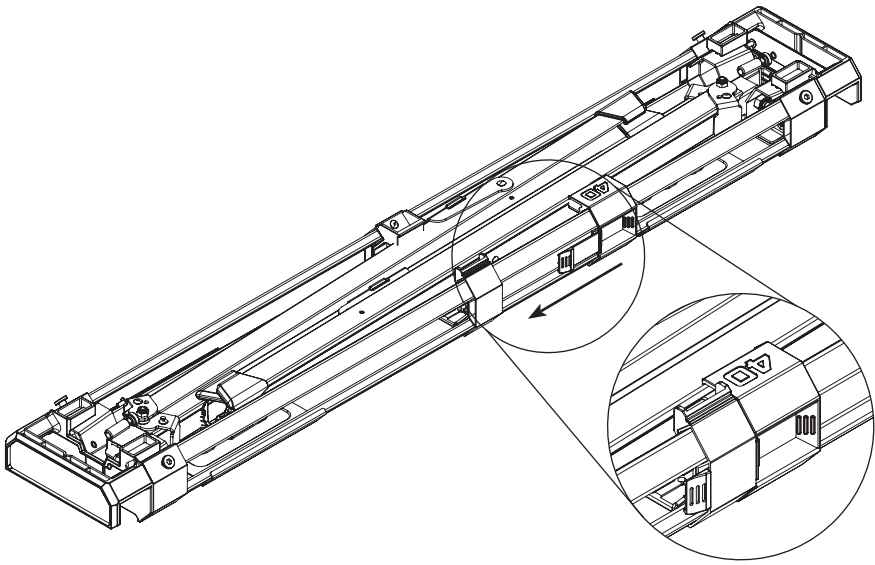

5. Slide leg lock to secure legs in place for transport and storage.

SAFETY AND WARNINGS

SAFETY INSTRUCTIONS FOR SAWHORSES

1. Use caution when folding or unfolding legs to limit any finger pinch points.
2. Place sawhorse on flat and level surface to keep from rocking or tipping.
3. Do not exceed the rated capacity on main frame table/chassis.
4. Ensure load is equally distributed.
5. Test the setup for stability before proceeding with work.
6. Never stack sawhorses to obtain extra height.
7. Do not sit or stand on sawhorse.

GENERAL SAFETY INSTRUCTIONS FOR POWER TOOLS

Using power tools of any kind can be dangerous if safe operating procedures are not followed. Recognizing the hazards of each tool and using them with respect and caution will considerably limit the possibility of personal injury. However, if safety precautions are ignored, personal injury can likely result. Always use common sense - your personal safety is your responsibility.

1. Know your power tool. Read and understand the product manual and observe the warnings and instruction labels affixed to the tool.
2. Properly ground all tools.
3. Keep guards in place.
4. Remove adjusting keys and wrenches.
5. Keep work area clean and dry.
6. Keep children away.
7. Never leave running machines/tools unattended.
8. Disconnect tools from service.
9. Use correct tools for the job.
10. Never force a tool.
11. Wear proper safety glasses/goggles and apparel.
12. Never stand or sit on tools.
13. Replace damaged components immediately.
14. Make sure your work platform is sufficiently sturdy to do the specific job at hand.
15. Properly anchor blade for job being done.
16. Use correct blade for job being done.

GENERAL MAINTENANCE

Avoid using solvents when cleaning plastic parts. Most plastics are susceptible to damage from various types of commercial solvents and may be damaged by their use. Use a clean cloth to remove dirt, dust, oil, grease, etc.

WARRANTY

3-YEAR

LIMITED WARRANTY

This product is backed by a 3-year limited warranty. This warranty covers manufacturer defects and workmanship. The warranty excludes misuse or abuse and normal wear and tear. This warranty gives you specific legal rights, and you may have other rights, which vary from state to state.

Contact manufacturer directly for questions/comments, technical assistance, or repair parts. Call toll free at: 1-877-707-6449 (Mon - Fri 7:00 AM - 5:00 PM PT), or visit PROTOCOLEQUIPMENT.COM.



TM

PROTOCOL™

02.27.2023

JS PRODUCTS • 6445 MONTESSOURI STREET • LAS VEGAS, NV 89113
CUSTOMER SERVICE: 1-877-707-6449 • PROTOCOLEQUIPMENT.COM