

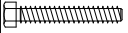



ASSEMBLY INSTRUCTIONS

209204-2304/209217-2304 SIDE CHAIR

Thank you for purchasing this quality product. Be sure to check all packing material carefully for small parts, which may have come loose inside the carton during shipment. Identify and count all parts and compare with the Hardware List below.

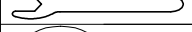
Caution: Overly tightening screws or bolts may break the wood parts.

| NO | Hardware List | | | Q'ty |
|----|---|-------------|--------------|------|
| A |  | Bolt | 5/16"X1-3/4" | 1 |
| B |  | Bolt | 5/16"X3-1/4" | 4 |
| C |  | Bolt | 5/16"X2-1/2" | 4 |
| D |  | Wrench | 5/16" | 1 |
| E |  | Flat Washer | 5/16" | 9 |
| F |  | Lock Washer | 5/16" | 9 |

| Parts List | | |
|------------|-------------|--------|
| NO | Description | Pieces |
| 1 | Chair Back | 1 |
| 2 | Seat Frame | 1 |
| 3 | Front Leg | 2 |
| 4 | Stretcher | 1 |
| 5 | Foot | 4 |

STEP ONE: Assemble the chair back(1) and the seat frame(2) using flat washer(E) , lock washer(F) and bolt(A) to fit into the center hole on the back of the seat frame(2).

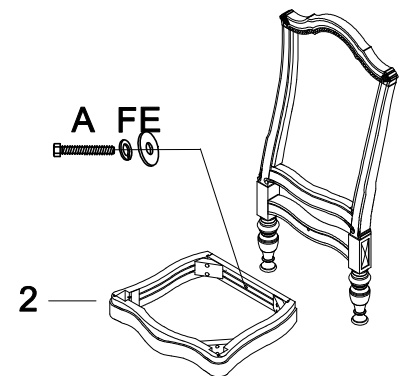

STEP TWO: Assemble the chair back(1) and the seat frame(2) securely using flat washers(E) , lock washers(F) and bolts(B).

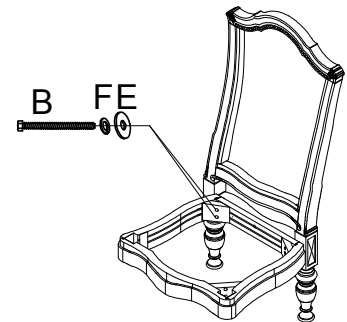

STEP THREE: Assemble the front legs(3) and the seat frame(2) using flat washers(E) , lock washers(F) and bolt(C). Fix the stretcher(4) by securing the feet(5) to the threaded-inserts on the legs.

