



BESTAR



<http://bestar.ca>

<http://bestar.com>

MODEL.MODELE.MODELO

KWS125LW-03
KWS125WT-03

WO

**ASSEMBLY
INSTRUCTIONS**

**INSTRUCTIONS
D'ASSEMBLAGE**

**INSTRUCCIONES DE
ENSAMBLAJE**

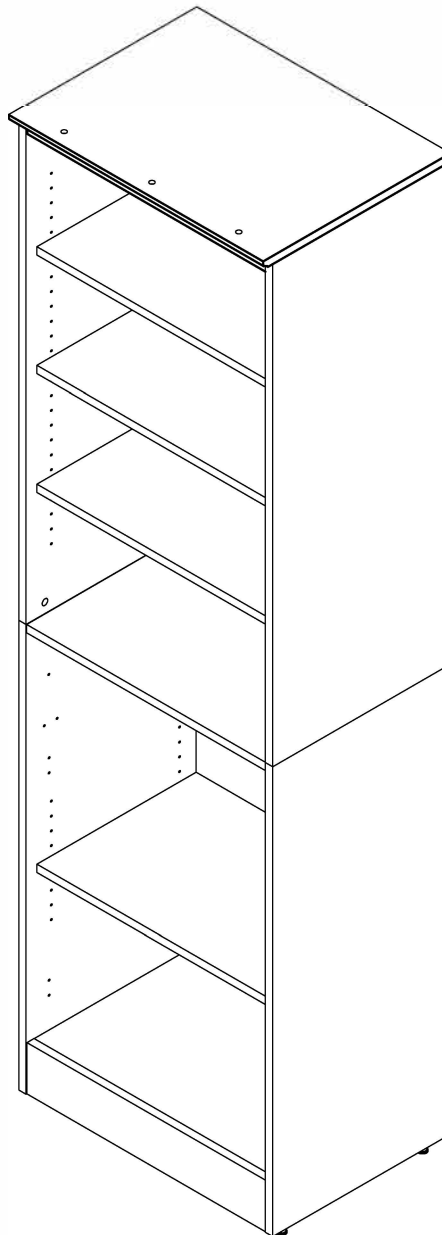

Video assembly guides
Guides d'assemblage en vidéo
Instrucciones de ensamblaje de video

www.bestar.com/video-assembly-guides

SERVICE/SERVICIO: 1-888 8BESTAR (1-888 823-7827)

Warranty Information

Informations relatives à la garantie

Información sobre la garantía



Should you need more information concerning the warranty, do not call to the place of purchase. Please call our customer service department for immediate assistance using the toll free number below. Please have your assembly instruction manual on hand when you call.

BESTAR products are warranted to the original purchaser against defects in material or workmanship in the furniture. Defects as mentioned in this warranty refer to any imperfections which may impair the use of the product. Our warranty is expressly limited to the replacement of furniture parts and components for the time specified in the product description and following the date of purchase. BESTAR will replace any part that is defective. This warranty applies under conditions of normal use. Our furniture products are not intended for outdoor use, except those in the Outdoor Collection. The warranty does not cover labor or assembly costs or defects caused by improper assembly or disassembly, after-purchase product modifications, intentional damage, accidents, or exposure to the elements. Bestar reserves the right to request a proof of purchase to document a warranty claim. In no event shall BESTAR be liable for incidental or consequent damages resulting from the misuse of the product. This warranty is not transferable and is valid only in Canada and the United States excluding Alaska, Hawaii and Puerto Rico.

Si vous souhaitez de plus amples informations concernant votre garantie, ne vous adressez pas au magasin où vous avez effectué votre achat. Pour obtenir une aide immédiate, veuillez appeler notre service client au numéro sans frais ci-dessus. Veuillez avoir en main le manuel d'instructions lors de votre appel.

La garantie des produits BESTAR est valide pour l'acheteur initial en cas de défaut de matériaux ou de fabrication. Les défauts couverts par cette garantie incluent toutes les imperfections qui peuvent nuire à l'utilisation normale du produit. Notre garantie est expressément limitée au remplacement des composants et des éléments de meubles pour une durée spécifiée sur la fiche produit et suivant la date de l'achat. BESTAR s'engage à remplacer tout élément défectueux. Cette garantie s'inscrit dans le cadre d'une utilisation du produit dans des conditions normales. Nos meubles ne sont pas destinés à être utilisés à l'extérieur, sauf ceux de la collection Outdoor. La garantie ne couvre pas les coûts de main-d'œuvre ou d'assemblage ni les défauts causés par un assemblage ou un démontage non conforme, par des modifications apportées au produit, par des dommages intentionnels, par un accident ou par l'exposition des meubles aux intempéries. Bestar se réserve le droit d'exiger une preuve d'achat afin de documenter la réclamation. La société BESTAR ne pourra être tenue, en aucun cas, responsable de dommages indirects ou consécutifs suite à une mauvaise utilisation du produit. Cette garantie ne peut être transférée et est valide au Canada et aux États-Unis sauf à Hawaï, à Puerto Rico et en Alaska.

Si necesita más información sobre la garantía, no vaya al lugar donde realizó la compra. Llame a nuestro departamento de atención al cliente para recibir ayuda inmediata utilizando nuestro servicio de llamada gratuita. Cuando llame, tenga a mano su manual de instrucciones de montaje.

Los productos BESTAR están garantizados por el comprador original contra defectos en el material o en la confección del mueble. Los defectos, tal como se describen en esta garantía incluyen toda imperfección que pueda impedir el uso normal del producto. Nuestra garantía se limita expresamente al reemplazo de las partes y componentes del mueble defectuosos por diez años a partir de la fecha de compra. BESTAR reemplazará cualquier pieza defectuosa. Esta garantía se aplica según las condiciones de uso normal. Nuestros productos no están diseñados para ser utilizados al aire libre. La garantía no cubre defectos causados por ensamblaje o desensamblaje incorrectos, defectos ocurridos luego de la compra por la modificación del mueble, daños intencionales, accidentes, exposición a los agentes naturales ni costos derivados de la fabricación o ensamblaje. Bestar se reserva el derecho de solicitar una factura de compra para poder extender un reclamo de garantía. Bajo ninguna circunstancia BESTAR será responsable de los daños accidentales o consecuentes que pudieran resultar del uso incorrecto del producto. Esta garantía es intransferible y se aplica solamente a Canadá y los Estados Unidos.



If there are parts missing from your order or if your product was damaged during shipping,
PLEASE CONTACT US DIRECTLY.

S'il vous manque des pièces ou si votre meuble a été endommagé pendant le transport,
VEUILLEZ NOUS CONTACTER DIRECTEMENT.

En caso de piezas faltantes o si su producto fue dañado durante el envío,
POR FAVOR CONTÁCTENOS DIRECTAMENTE.

Need help? • Questions? • ¿Cuestión?

If you have any questions or concerns,
please visit our website:

Si vous avez des questions ou des préoccupations,
veuillez visiter notre site web à l'adresse :

Si tiene dudas o inquietudes, visite nuestro sitio web:



www.bestar.com/support

or call our toll-free number:
ou appeler sans frais au :
o llame sin costo a:
1-888 823-7827



Make a phone appointment
Prenez un rendez-vous téléphonique
Agendar una cita telefónica
www.bestar.com/online-appointment



Send us an email
Envoyez-nous un courriel
Envíenos un correo electrónico
www.bestar.ca/contact-us



Need help?
Besoin d'aide?
¿Necesita ayuda?
www.bestar.com/faq



Activate your warranty now:
Activez votre garantie dès maintenant :
Active su garantía:



www.bestar.com/activate-my-warranty

Information required to make a warranty claim
Éléments nécessaires pour présenter une réclamation
Información necesaria para hacer válida la garantía



A copy of your receipt.
Copie de votre reçu.
Una copia de su recibo de compra.



Pictures of the damaged parts.
Photos des pièces endommagées.
Fotos de las partes dañadas.



You must know the name of the product, the item number and the name of the store where the item was purchased.
Repérez votre produit sur Bestar.com. Vous devez connaître le nom du produit, le numéro d'article et le nom du magasin où vous l'avez acheté.
Debe conocer el nombre y el número del producto y, el comercio donde realizó la compra.



Please collect this information BEFORE contacting our customer service.
Veuillez recueillir tous ces renseignements AVANT de communiquer avec le service client.
Por favor, tenga toda esta información a la mano ANTES de contactar al departamento de servicio al cliente.



Never leave damp clothes, liquids or damp cloths on the furniture.

If a liquid has spilled on the furniture, clean the liquid up immediately.

Ne laissez jamais de liquide ni de vêtements ou de linge humides sur le meuble.

Si un liquide est renversé sur le meuble, épongez-le immédiatement.

Nunca deje líquidos o un trapos húmedos sobre su mueble.

Si se derrama un líquido sobre la superficie del mueble, límpielo inmediatamente.



Clean the furniture with a damp cloth, then wipe dry.

To avoid damaging the finish, do not use cleaning products on the furniture.

Nettoyez votre meuble avec un linge légèrement humide, puis essuyez-le ensuite.

N'utilisez pas de produits de nettoyage, car cela risque d'endommager le fini.

Nunca utilice limpiadores químicos, ya que estos dañarán el acabado.

Use solo un paño húmedo.



Do not put devices with plastic or rubber pads directly on your furniture. Instead, attach cloth or felt pads to your device.

Évitez de déposer des appareils munis de patins en caoutchouc ou en plastique directement sur le meuble. Utilisez des protecteurs en tissu ou en feutre sous les appareils.

Evite apoyar aparatos con bases de plástico o de goma directamente sobre su mueble.

Utilize un protector de tela o de fieltro.



To avoid dulling the finish, do not place furniture in direct sunlight.

Afin de préserver la belle apparence de votre meuble,
évittez de l'exposer à la lumière directe du soleil.

Para prevenir empañamiento, no exponga el mueble directamente a la luz solar solar.



At Bestar, we take pride in manufacturing stylish and functional furniture for your home and workspace. We go beyond manufacturing furniture: we offer solutions to optimize and customize your home and workspace. That's why customer satisfaction is our number one priority!

Chez Bestar, nous sommes fiers de fabriquer des meubles modernes et fonctionnels pour rehausser votre espace de vie ou votre lieu de travail. Plus encore, nous nous engageons à vous offrir des solutions pour optimiser et personnaliser votre résidence et votre espace de travail.

Voilà pourquoi votre entière satisfaction nous tient à cœur !

En Bestar nos enorgullecemos de crear muebles funcionales y modernos para su hogar y oficina. Vamos más allá de la fabricación de muebles: ofrecemos soluciones para optimizar y personalizar su hogar u oficina. Por eso su satisfacción es nuestra prioridad número uno.

Satisfaction Survey
Sondage de satisfaction
Encuesta de satisfacción



Stay in touch with us
Restez en contact avec nous
Manténgase en contacto con nosotros

www.bestar.com/blog



IMPORTANT SAFETY INFORMATION



PLEASE READ WARNINGS

Improper use can cause safety hazards, or damage to your furniture and household items.

Warning	Do	Don't	Why it's important
Serious injury may occur.	<ul style="list-style-type: none">Assemble following all instructions using all indicated parts and hardware provided.Install tip-over restraint provided.Install every indicated nail and/or screw.Verify furniture is stable on it's own.Place heaviest items in the lower drawers.Remove items that might tempt kids to climb, such as toys and remote controls from the top and upper shelves of furniture.	<ul style="list-style-type: none">Do not move unit when loaded.Do not load with a television or other heavy equipment.Do not exceed the maximum load limits stated in the instructions.Do not allow children to stand, climb, or hang on furniture.	Improper assembly, use or loading can lead to product instability, tipover, or collapse.

Advertencia	Hacer	No	Por qué es importante
Pueden producirse lesiones graves.	<ul style="list-style-type: none">Realice el montaje siguiendo todas las instrucciones y utilizando todas las piezas indicadas y los herrajes suministrados.Instale el sistema de retención antivuelco suministrado.Instale todos los clavos y/o tornillos indicados.Compruebe que el mueble sea estable por sí mismo.Coloque los objetos más pesados en los cajones inferiores.Retire los objetos que puedan tentar a los niños a trepar, como juguetes y mandos a distancia, de los estantes superiores y superiores del mueble.	<ul style="list-style-type: none">No mueva la unidad cuando esté cargada.No cargue el mueble con un televisor u otro equipo pesado.No supere los límites máximos de carga indicados en las instrucciones.No permita que los niños se pongan de pie, trepen o se cuelguen de los muebles.	El montaje, uso o carga inadecuados pueden provocar inestabilidad, vuelco o colapso del producto.

IMPORTANT SAFETY INFORMATION



PLEASE READ WARNINGS

Improper use can cause safety hazards, or damage to your furniture and household items.

Avertissement	À faire	À ne pas faire	Pourquoi c'est important
Peut entraîner des blessures graves.	<ul style="list-style-type: none">• Assembler en suivant toutes les instructions et en utilisant toutes les pièces et la quincaillerie incluses.• Installer le matériel de fixation mural inclus.• Installer tous les clous et/ou toutes les vis.• Assurez-vous que le meuble soit stable par lui-même.• Placer les objets les plus lourds dans les tiroirs du bas.• Retirer les objets qui pourraient inciter les enfants à grimper comme les jouets et les télécommandes des tablettes supérieures et du dessus du meuble.	<ul style="list-style-type: none">• Ne pas déplacer le meuble lorsqu'il est chargé.• Ne pas charger le meuble avec un téléviseur ou tout autre équipement lourd.• Ne pas dépasser les limites de poids maximales indiquées dans les instructions.• Ne pas laisser les enfants se tenir sur les meubles, y grimper ou s'y suspendre.	Un assemblage, une utilisation ou un chargement incorrects peuvent entraîner l'instabilité, le basculement ou l'effondrement du produit.

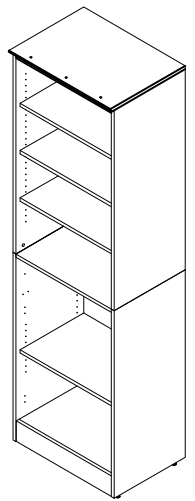
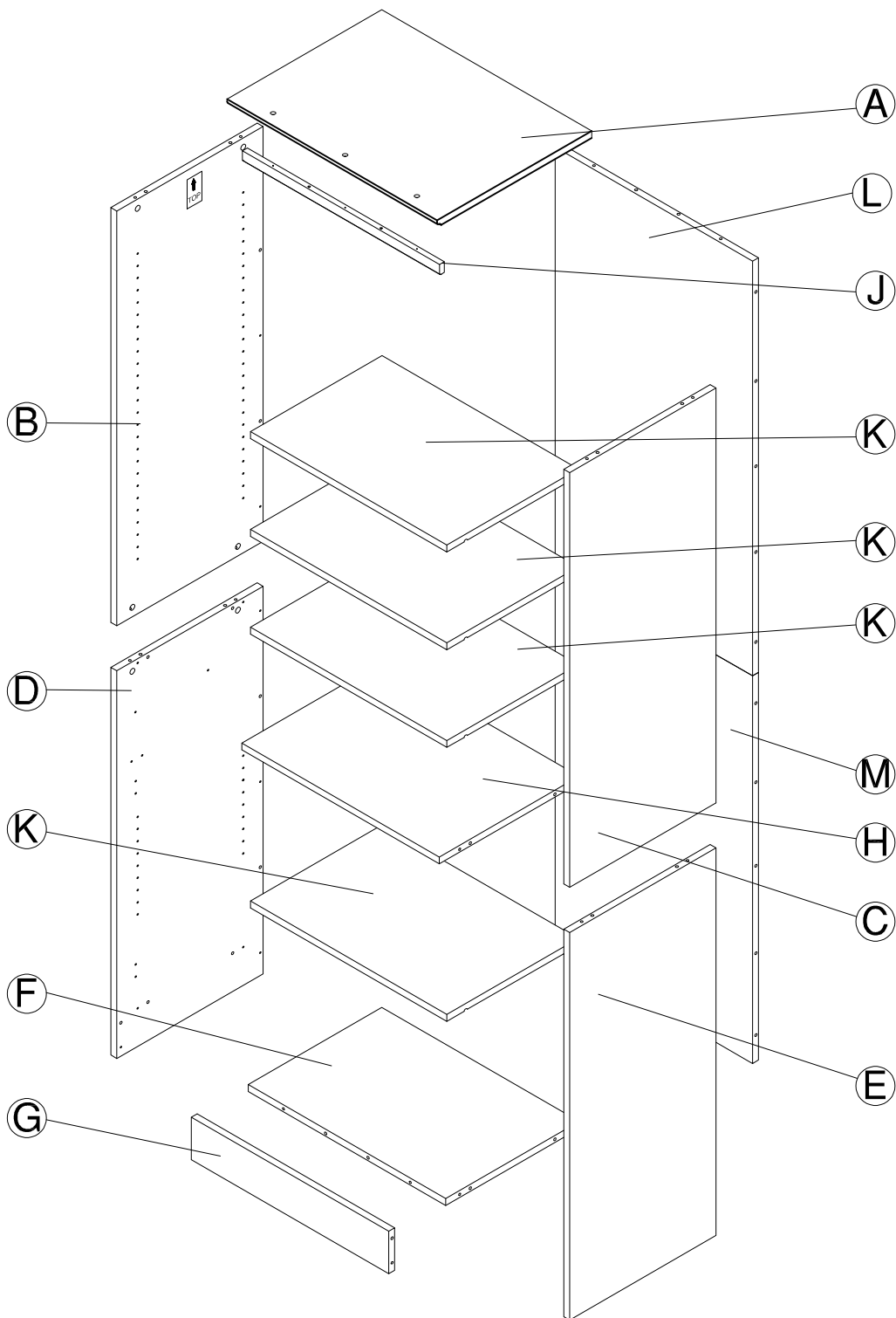

H181468

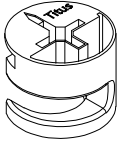

[42]

KD Cam

H72988

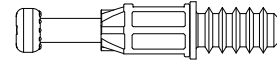

[30]

KD Bolt

H38169

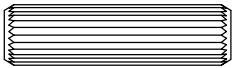

[28]

Wood Dowel
8 x 30mm

H26053

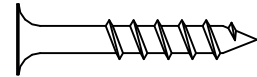

[3]

#10 x 1-1/4"

H157929



[6]

Double Ended KD Bolt

H147242



[6]

Wood Dowel
8 x 40mm

H209601

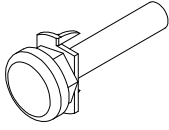

[4]

Leveler



[12]

Cover Cap

H23604



[16]

Shelf Pin 1"x 3/16"



[16]

Cover Cap 5mm

TIP OVER RESTRAINT HARDWARE

Q203419

H181434  [1]
#10x2"

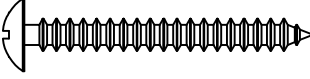
H107572  [1]
#8x1-1/2"

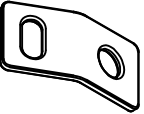
H181412  [2]
Connecting Plate

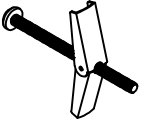
H181419  [1]
Toggle Bolt

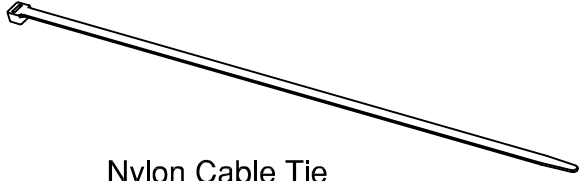
H181411  [1]
Nylon Cable Tie

H147242 [2]

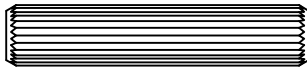

Wood Dowel
8 x 40mm

H72988 [8]

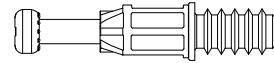

KD Bolt

H209601 [2]

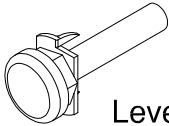

Leveler

[8]
Cover Cap 5mm



Orientation
Orientación
L'orientation

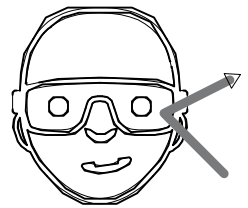

Safety glasses
Gafas de seguridad
Lunettes de protection

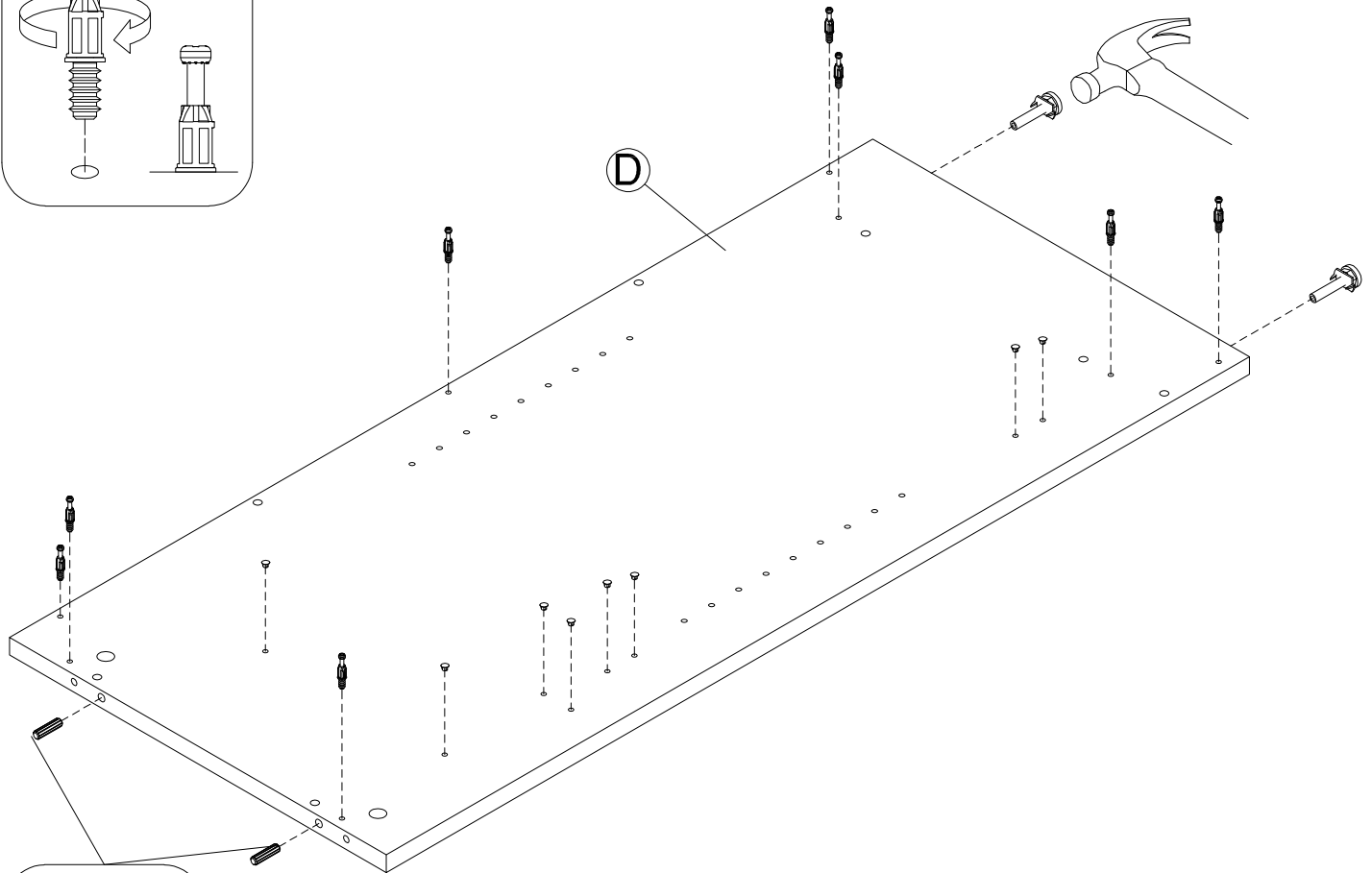
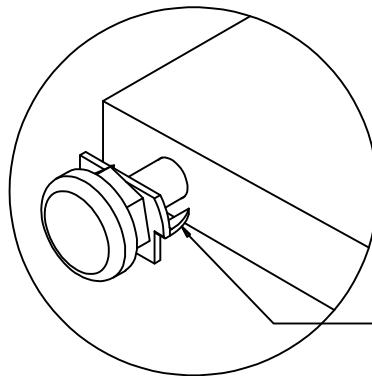
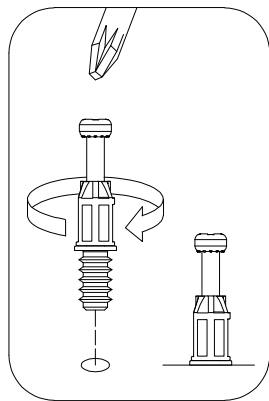

H147242

H147242 [2]

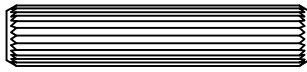

Wood Dowel
8 x 40mm

H72988 [8]

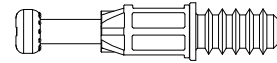

KD Bolt

H209601 [2]

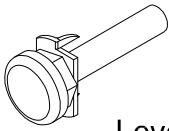

Leveler

[8]
Cover Cap 5mm

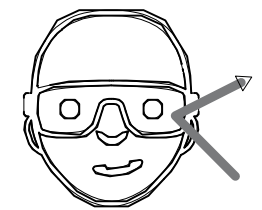

Safety glasses
Gafas de seguridad
Lunettes de protection

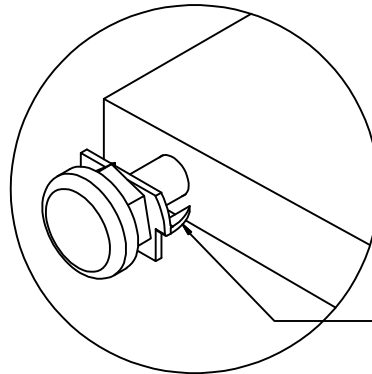

Orientation
Orientación
L'orientation

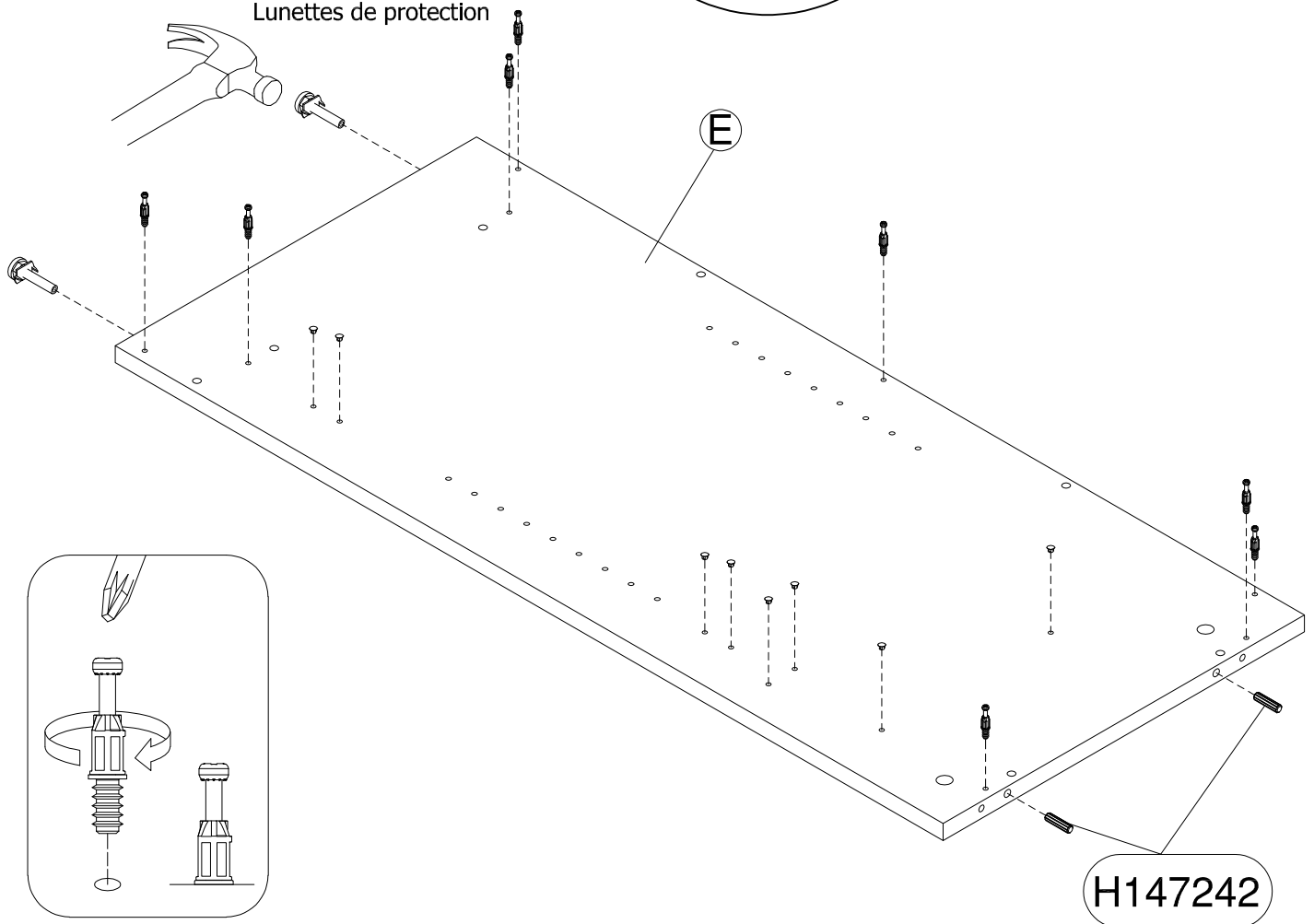

H38169

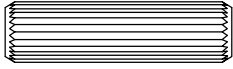

[2]

Wood Dowel
8 x 30mm

H72988

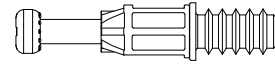

[3]

KD Bolt

H72988

B

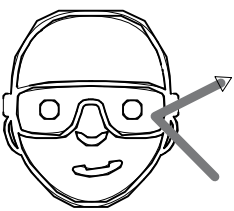
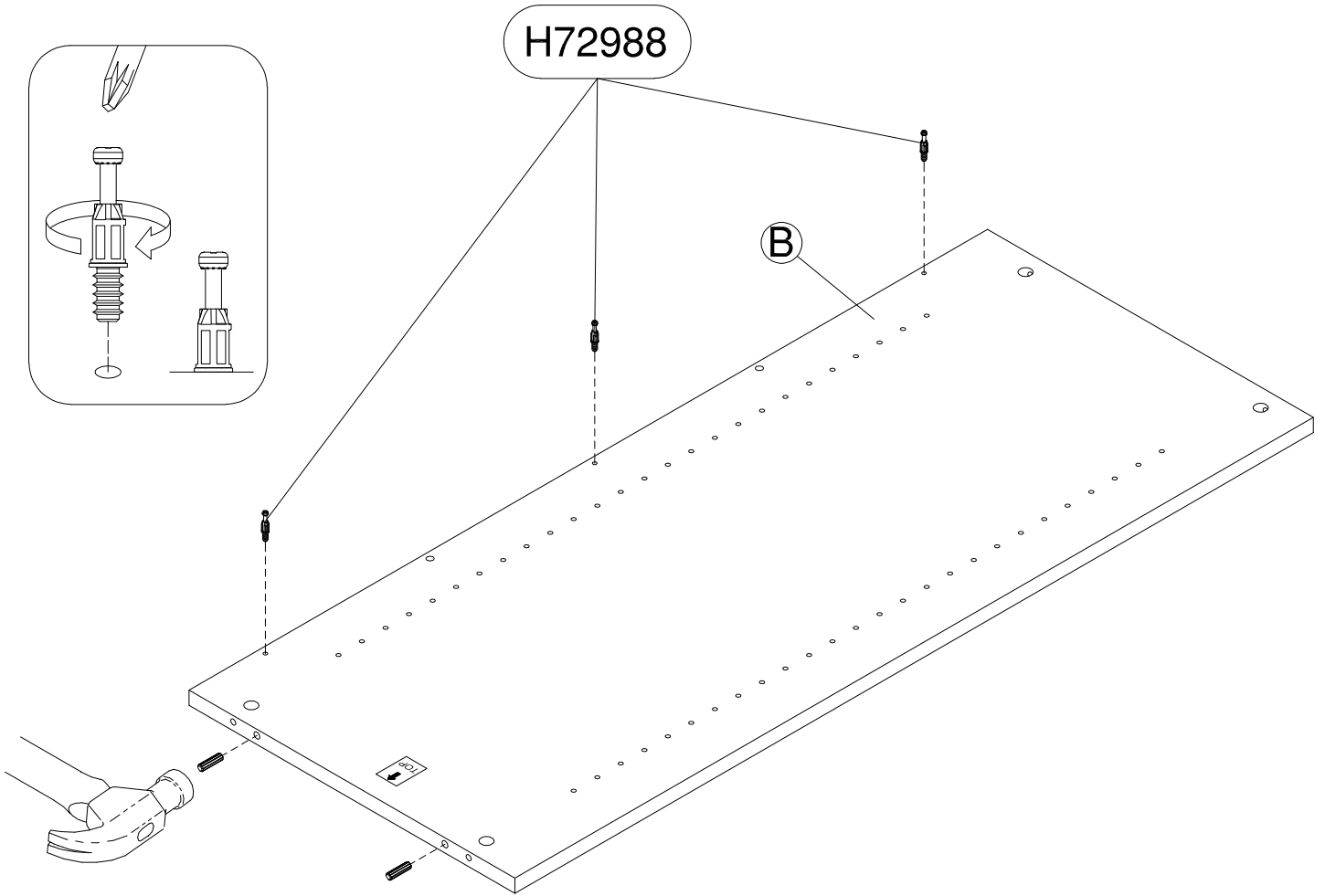

Safety glasses
Gafas de seguridad
Lunettes de protection

H38169

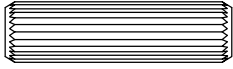

[2]

Wood Dowel
8 x 30mm

H72988

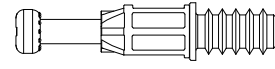

[3]

KD Bolt

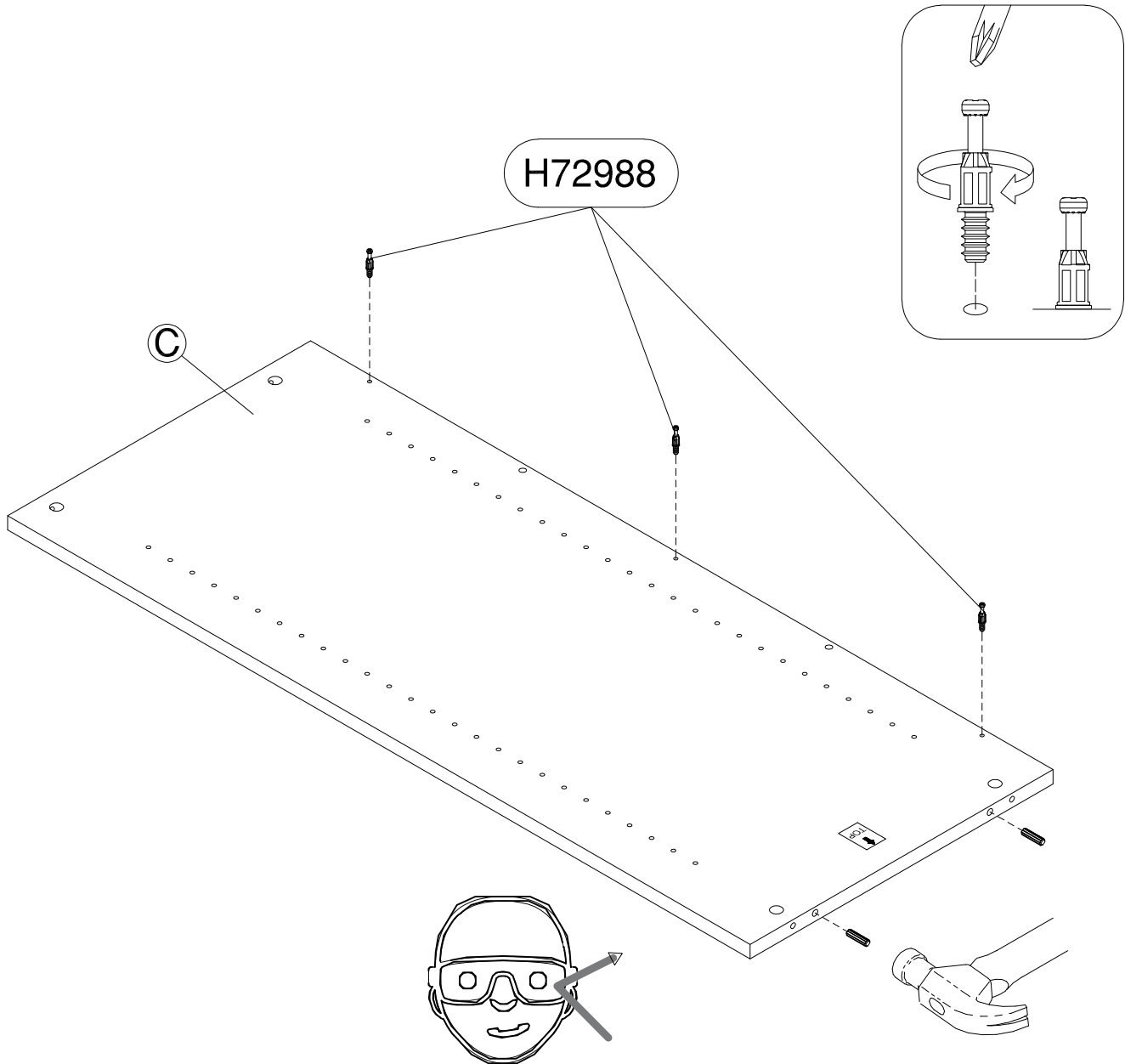

Safety glasses
Gafas de seguridad
Lunettes de protection

H38169

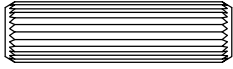

[14]

Wood Dowel
8 x 30mm

H72988

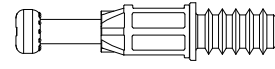

[2]

KD Bolt

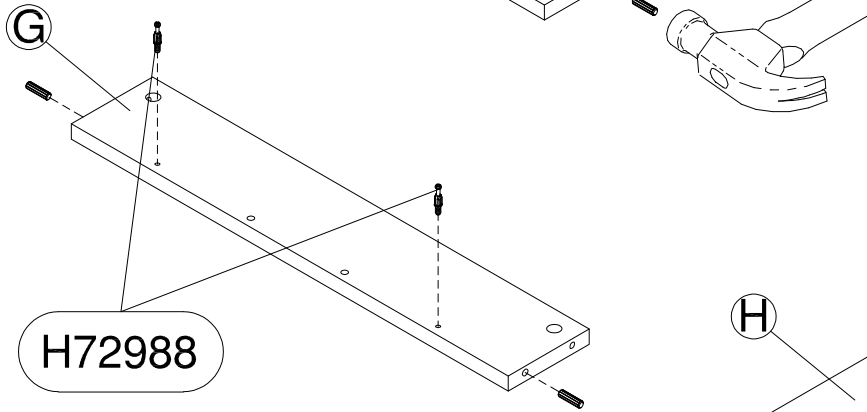
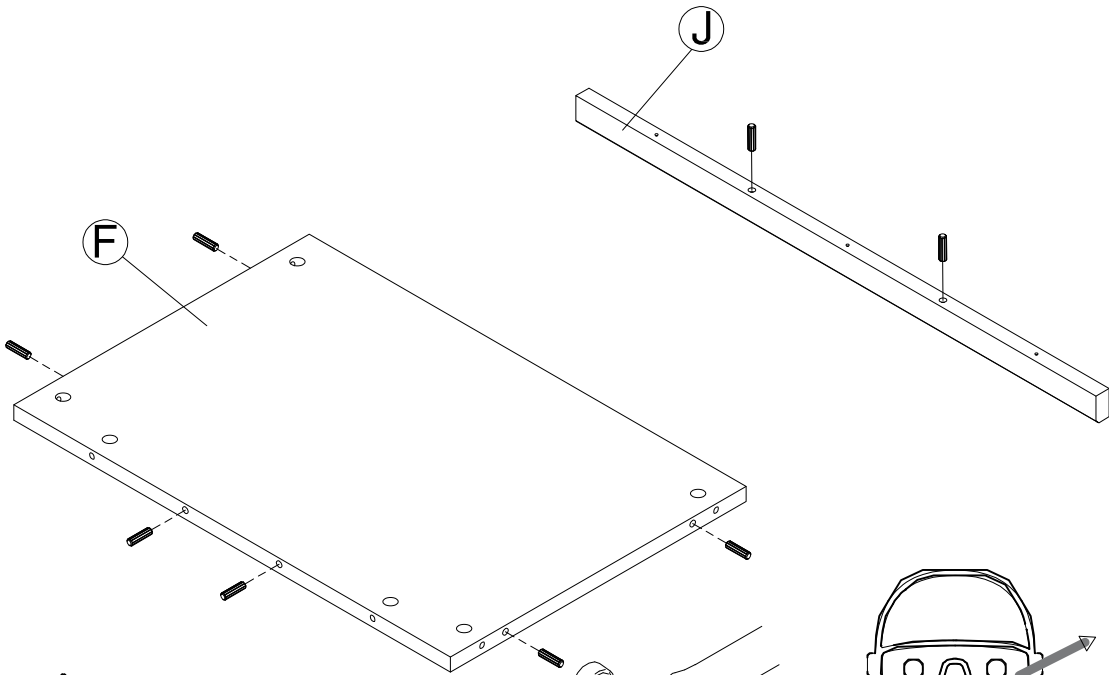

H72988

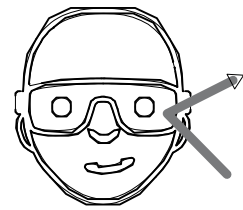

Safety glasses
Gafas de seguridad
Lunettes de protection

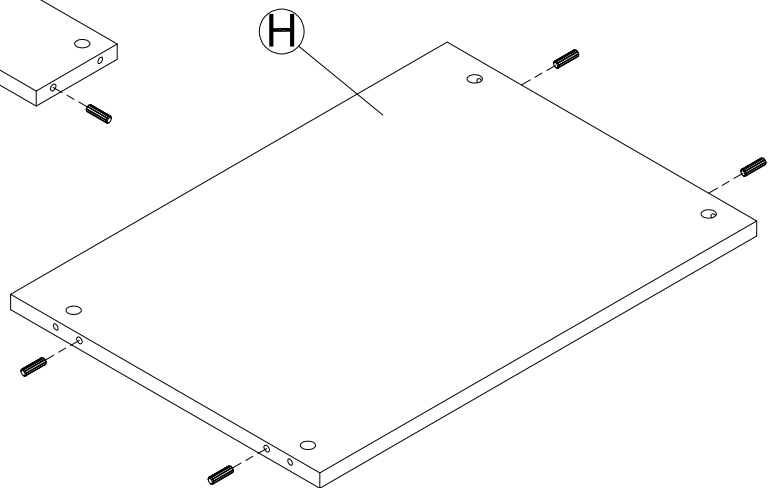
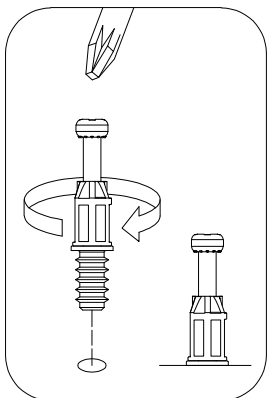

Scan QR Code to
Watch Video on:
Escancódigo QR a
Vea el Video sobre:
Scannez le Code QR pour
Regardez la vidéo sur:



H181468

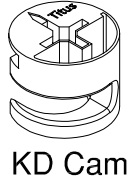

KD Cam

[2]

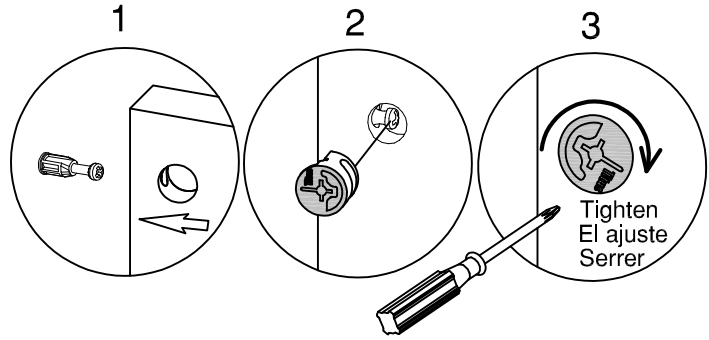

How to Tighten KD Cams
Cómo apre KD Cams
Comment serrer KD Cams

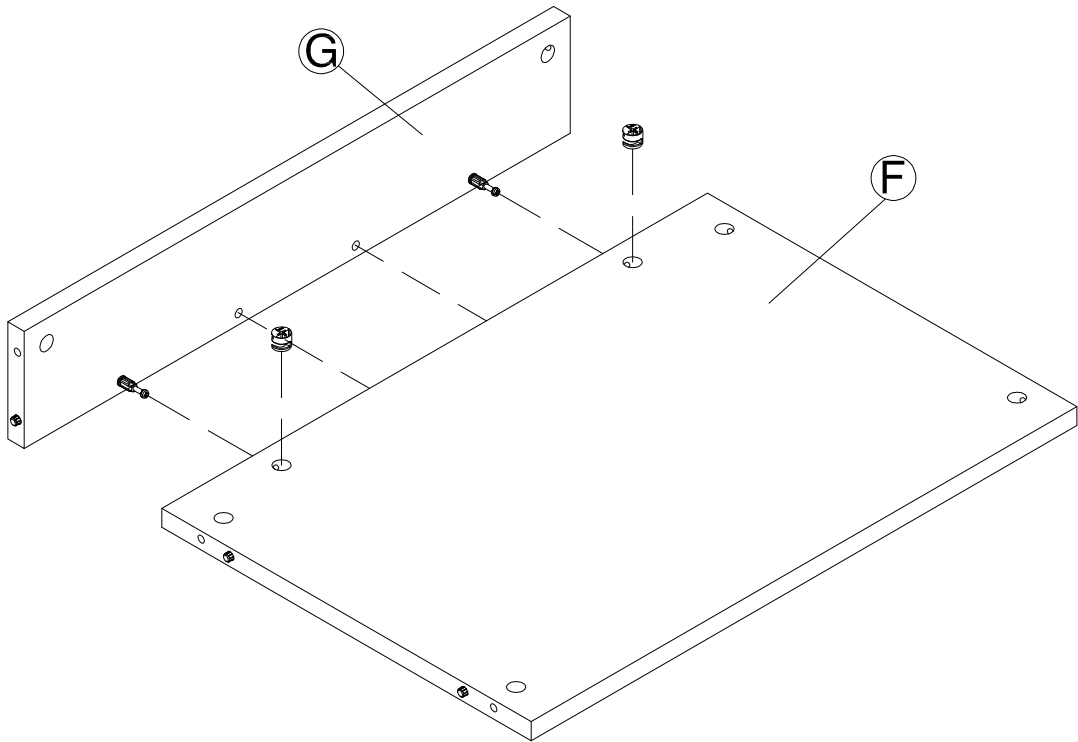

H26053

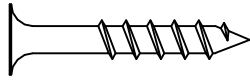

[3]

#10 x 1-1/4"

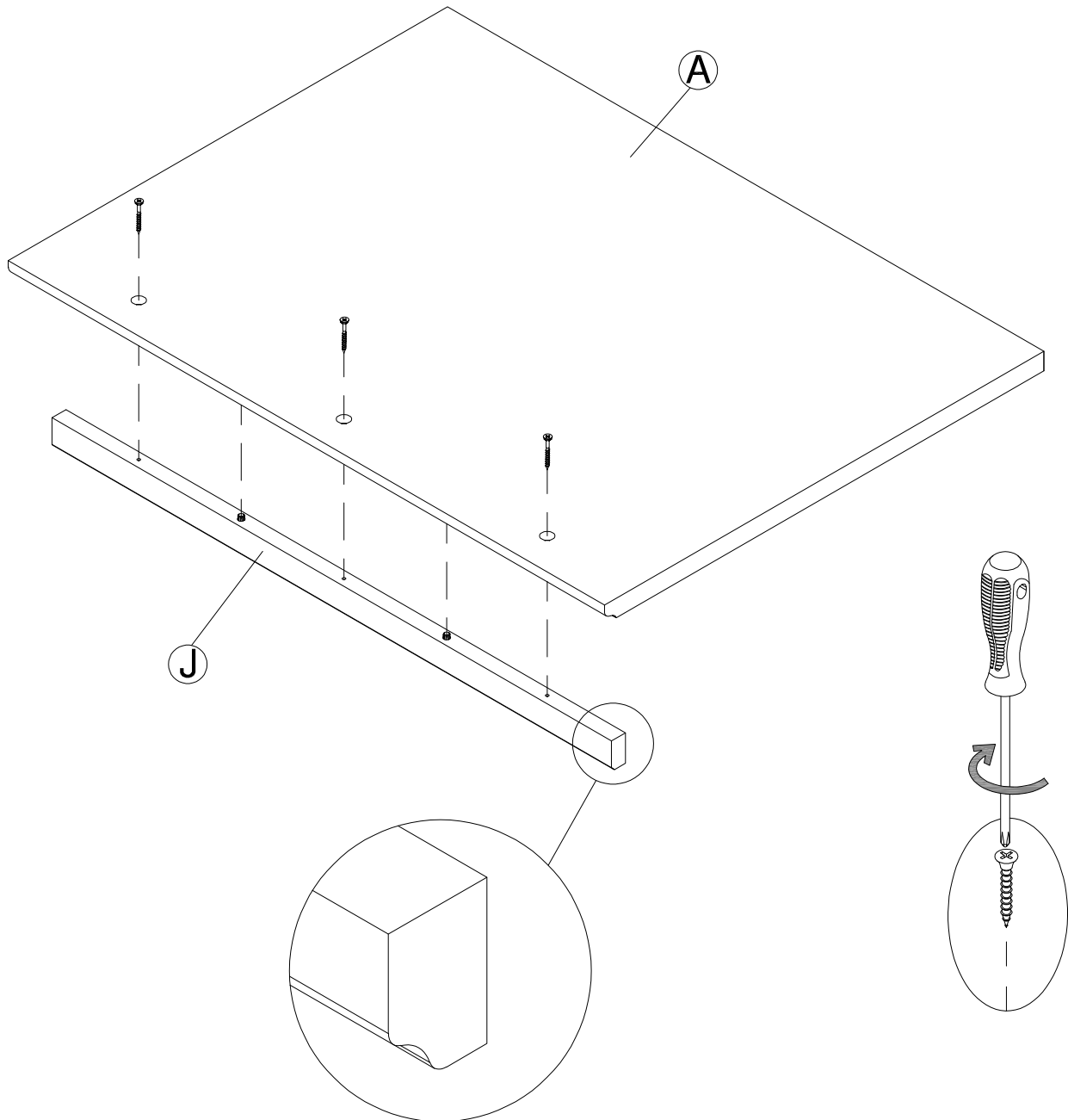

H72988

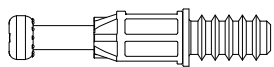

[6]

KD Bolt

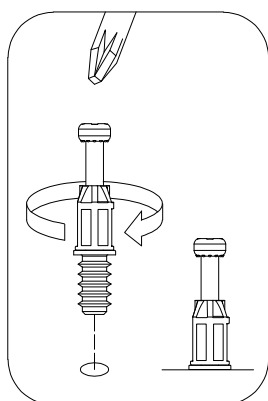
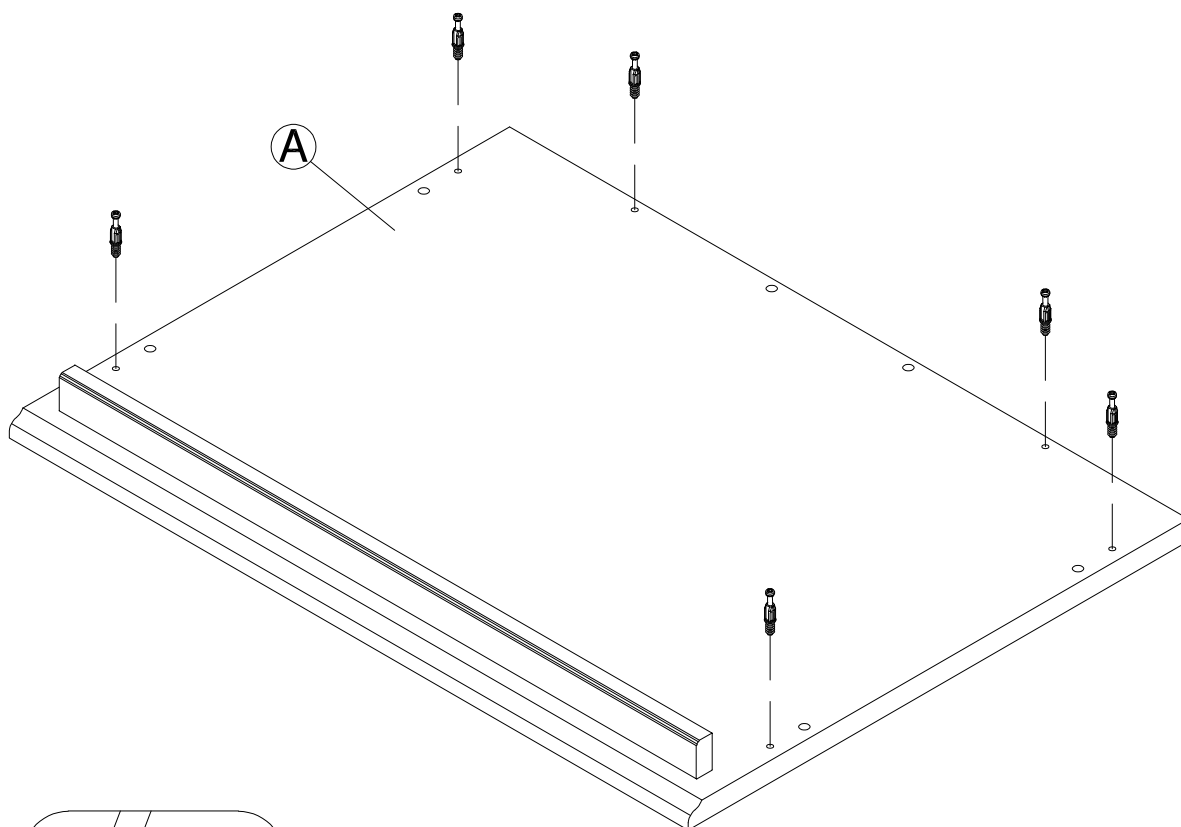

H38169

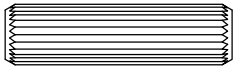

[10]

Wood Dowel
8 x 30mm

H147242



[2]

Wood Dowel
8 x 40mm



Safety glasses
Gafas de seguridad
Lunettes de protection

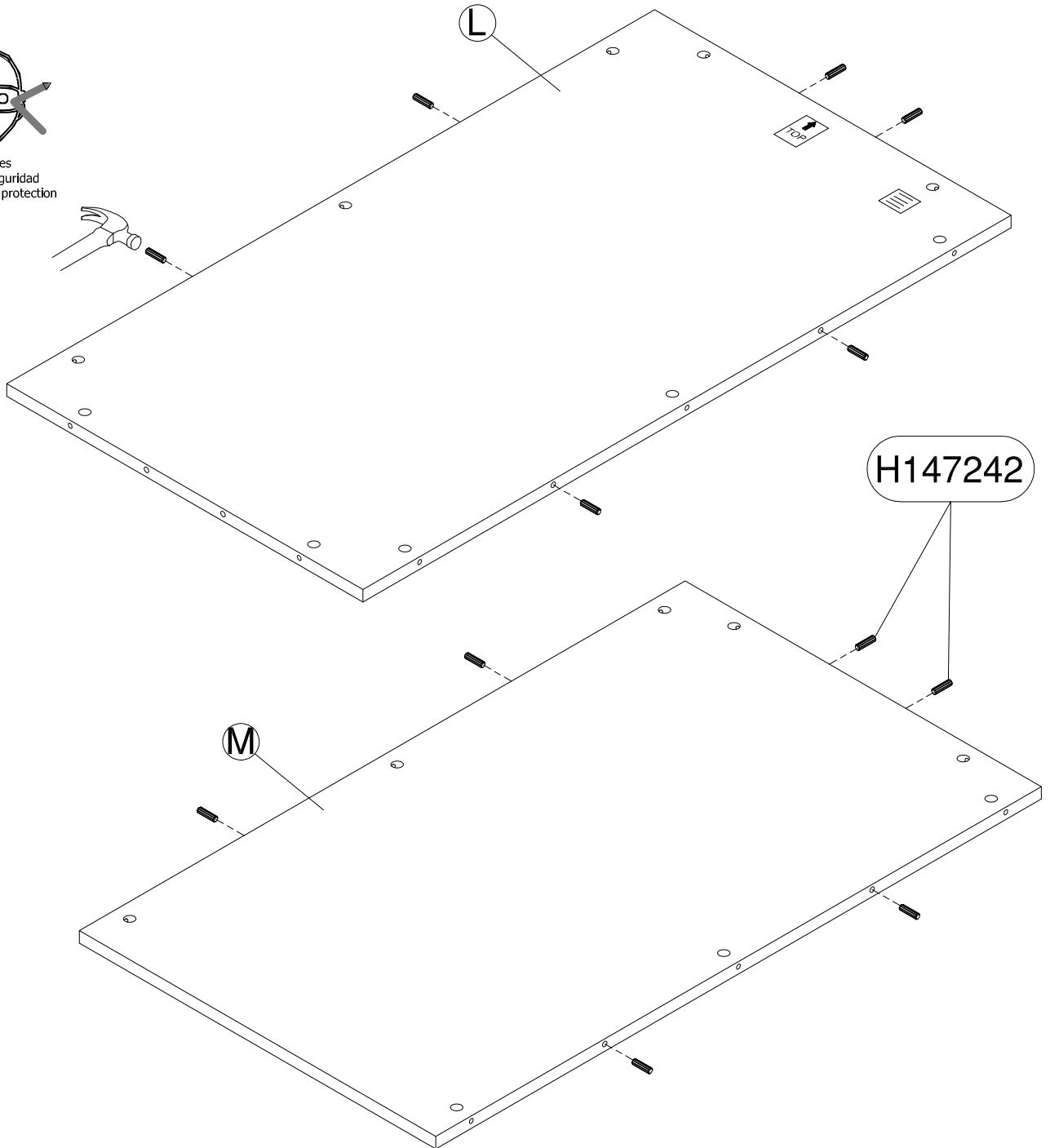

Scan QR Code to
Watch Video on:
Escancódigo QR a
Vea el Video sobre:
Scannez le Code QR pour
Regardez la vidéo sur:



H181468

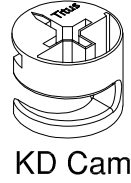

[5]

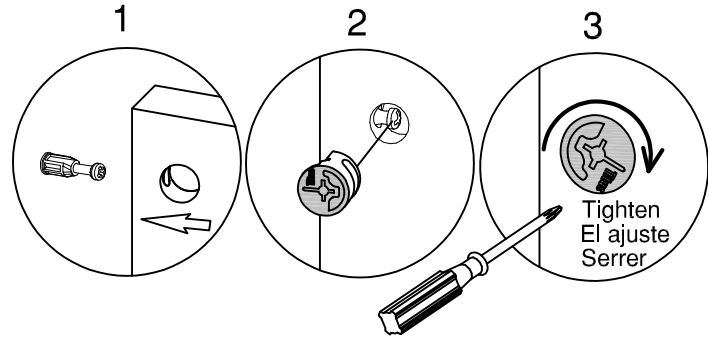

How to Tighten KD Cams
Cómo apre KD Cams
Comment serrer KD Cams

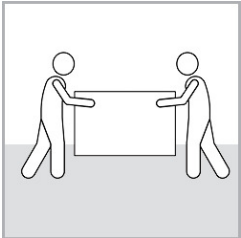

Team Lift

deux personne c'est mieux
dos personas es major

Finished edge
Borde terminado
Côté fini

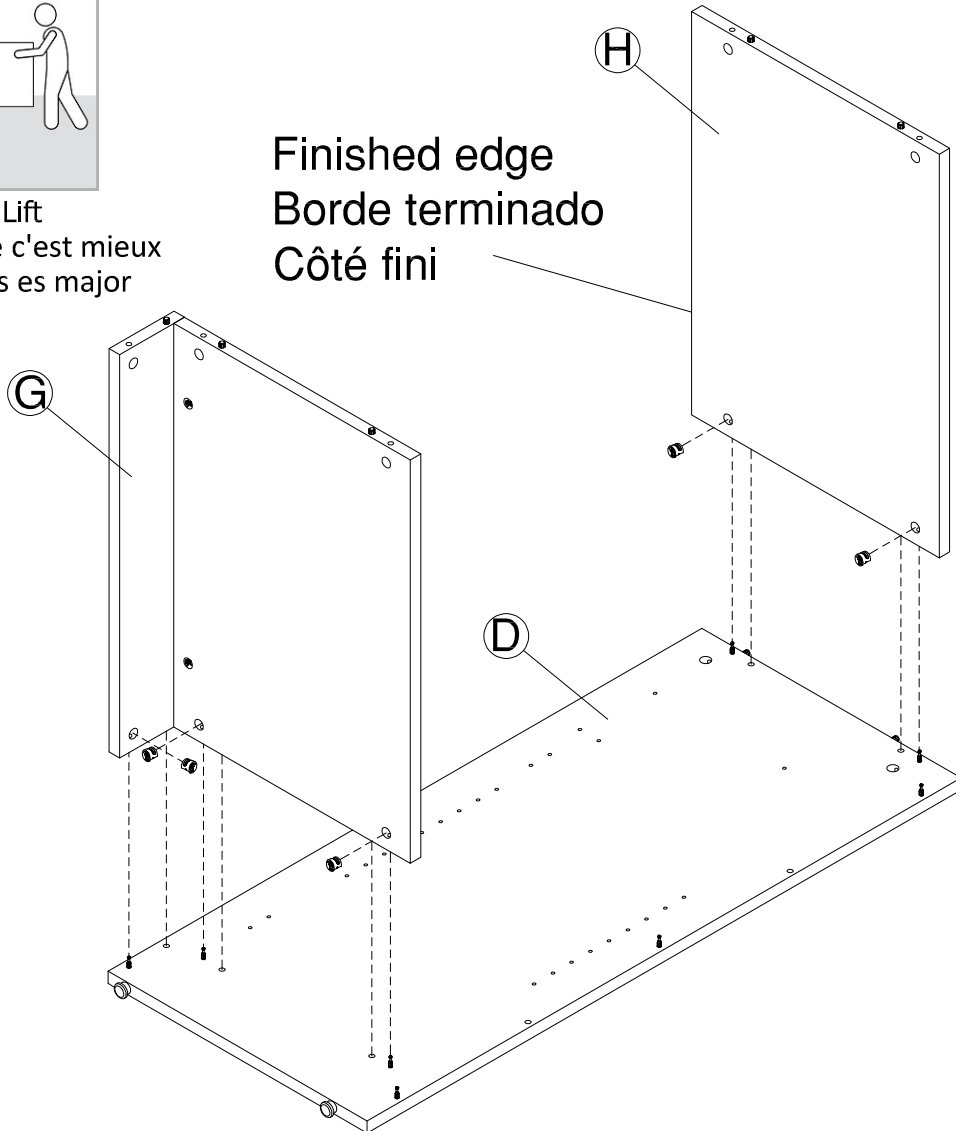

Scan QR Code to
Watch Video on:
Escancódigo QR a
Vea el Video sobre:
Scannez le Code QR pour
Regardez la vidéo sur:



H181468

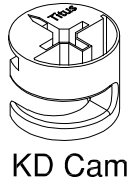

[3]

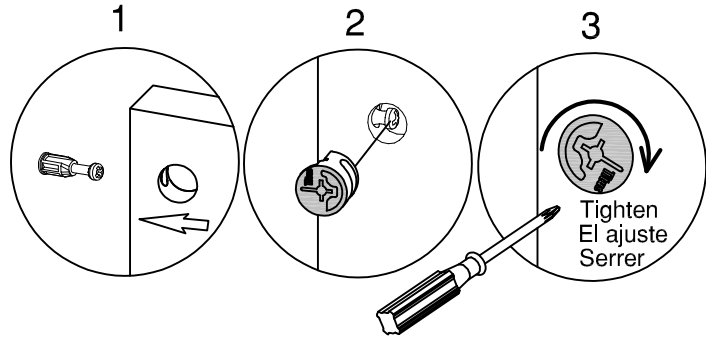

How to Tighten KD Cams
Cómo apre KD Cams
Comment serrer KD Cams

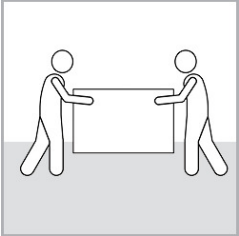

Team Lift

deux personne c'est mieux
dos personas es major

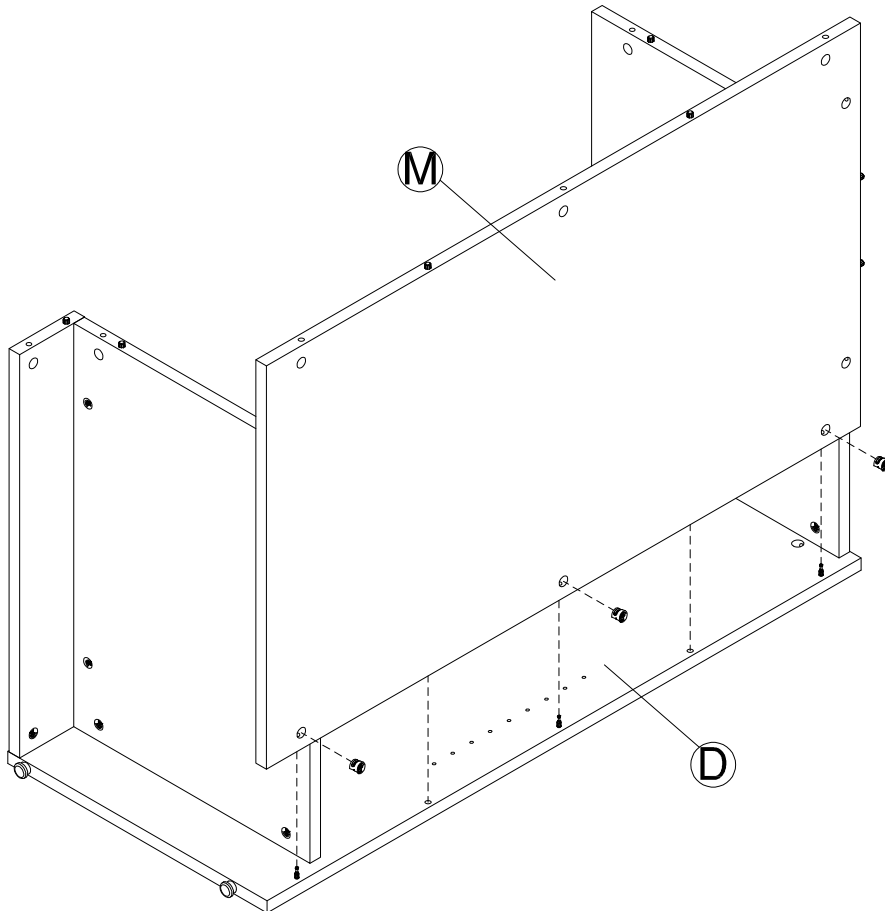

Scan QR Code to
Watch Video on:
Escancódigo QR a
Vea el Video sobre:
Scannez le Code QR pour
Regardez la vidéo sur:



H181468

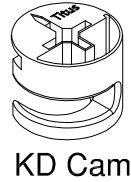

[10]

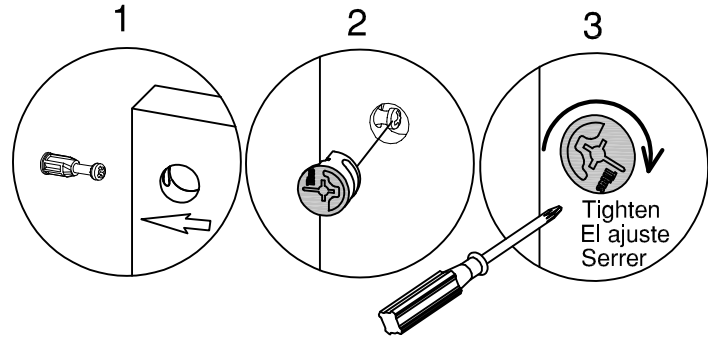

H157929



[2]

Double Ended KD Bolt

How to Tighten KD Cams
Cómo apre KD Cams
Comment serrer KD Cams

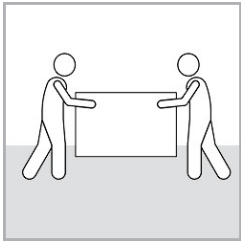

Team Lift

deux personne c'est mieux
dos personas es major

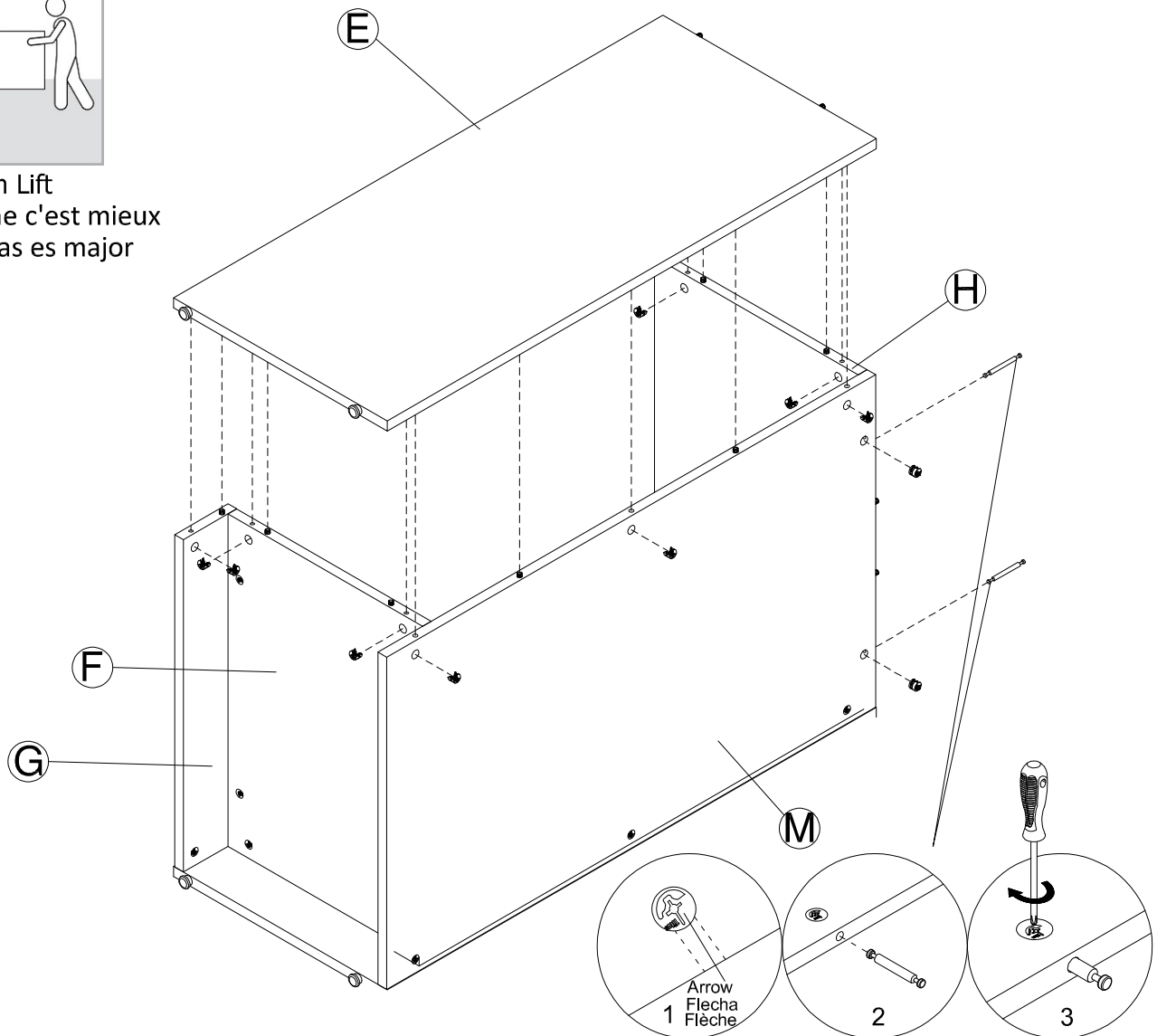

Scan QR Code to
Watch Video on:
Escancódigo QR a
Vea el Video sobre:
Scannez le Code QR pour
Regardez la vidéo sur:



H181468

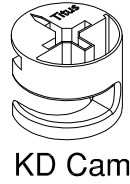

[4]

KD Cam

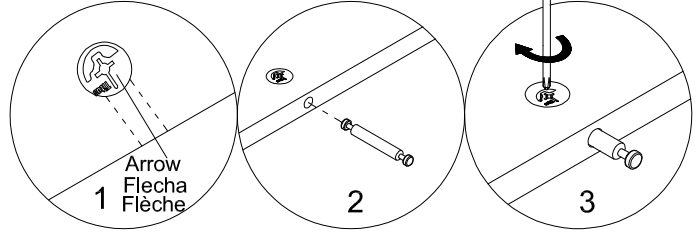

H157929

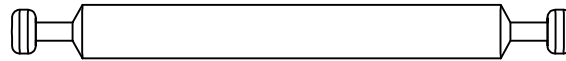

[4]

Double Ended KD Bolt

How to Tighten KD Cams
Cómo apere KD Cams
Comment serrer KD Cams

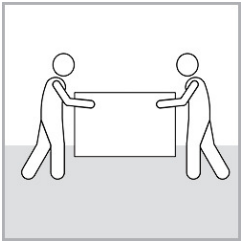

Team Lift

deux personne c'est mieux
dos personas es major

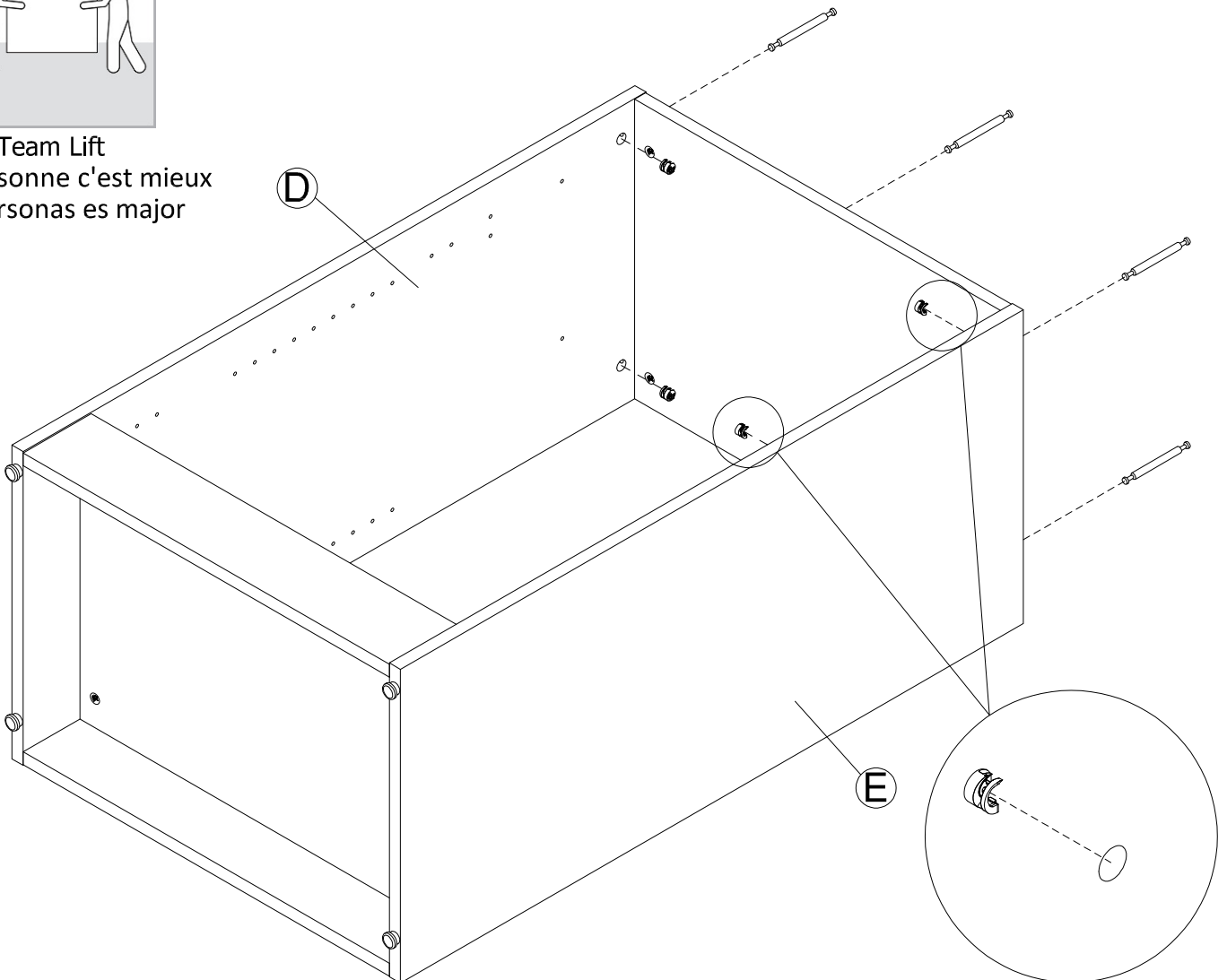

Scan QR Code to
Watch Video on:
Escancódigo QR a
Vea el Video sobre:
Scannez le Code QR pour
Regardez la vidéo sur:



H181468

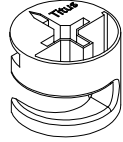

[3]

KD Cam

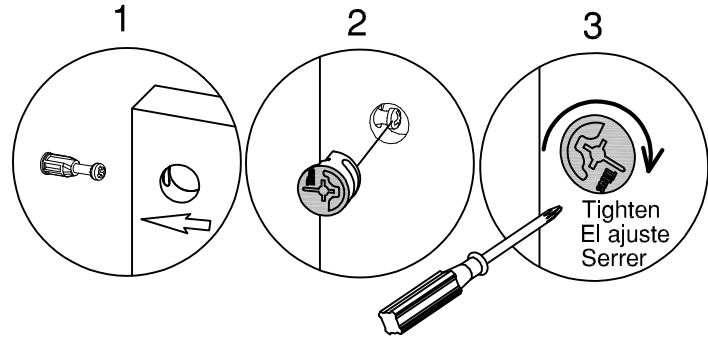

How to Tighten KD Cams
Cómo apre KD Cams
Comment serrer KD Cams

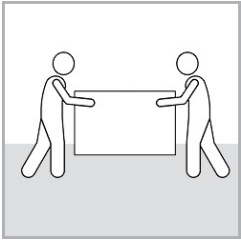

Team Lift

deux personne c'est mieux
dos personas es major

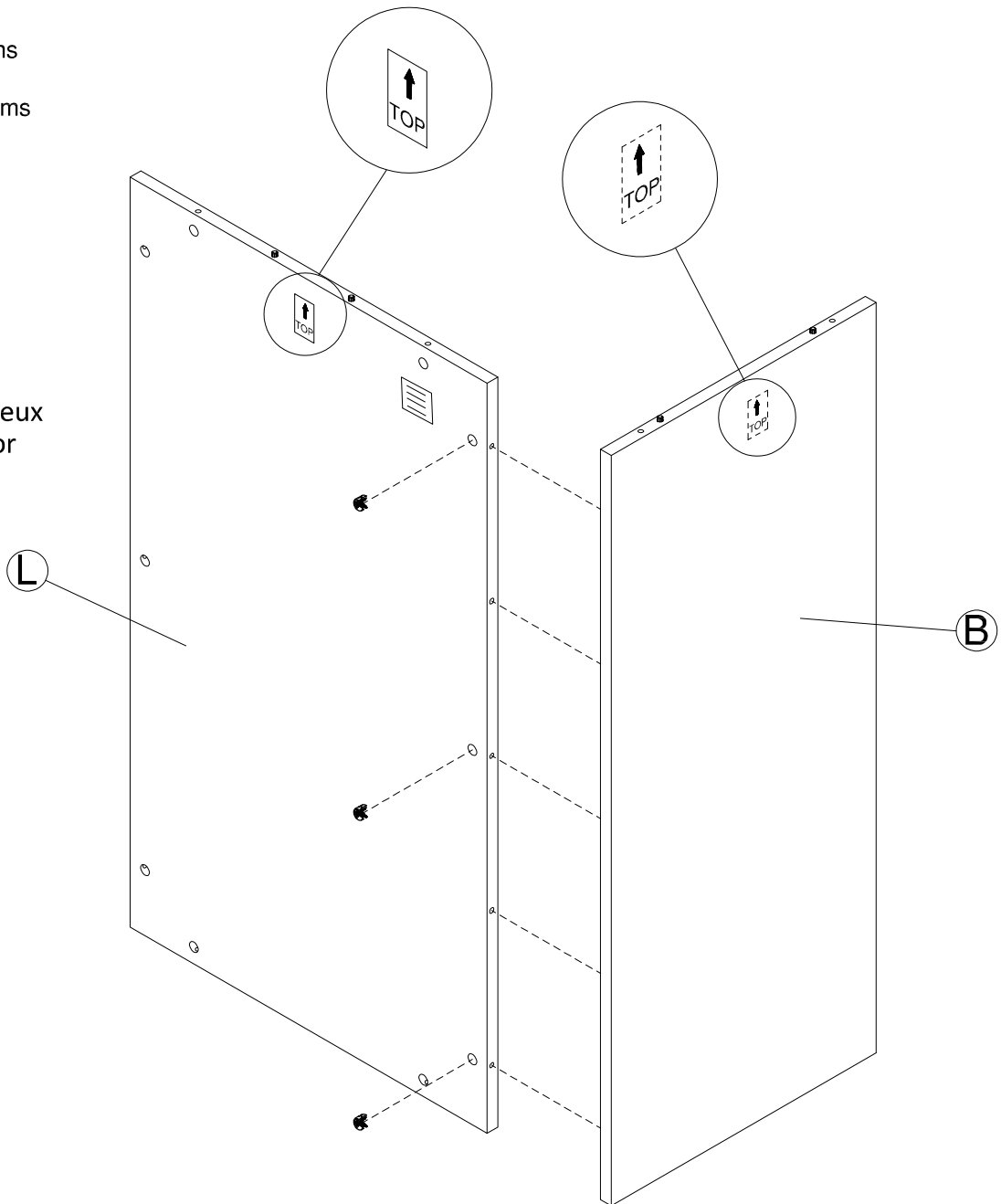

Scan QR Code to
Watch Video on:
Escancódigo QR a
Vea el Video sobre:
Scannez le Code QR pour
Regardez la vidéo sur:



How to Tighten KD Cams
Cómo apre KD Cams
Comment serrer KD Cams

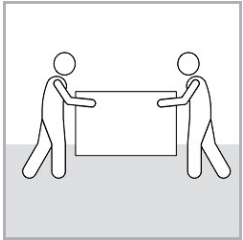

Team Lift
deux personne c'est mieux
dos personas es major

H181468

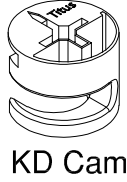

[3]

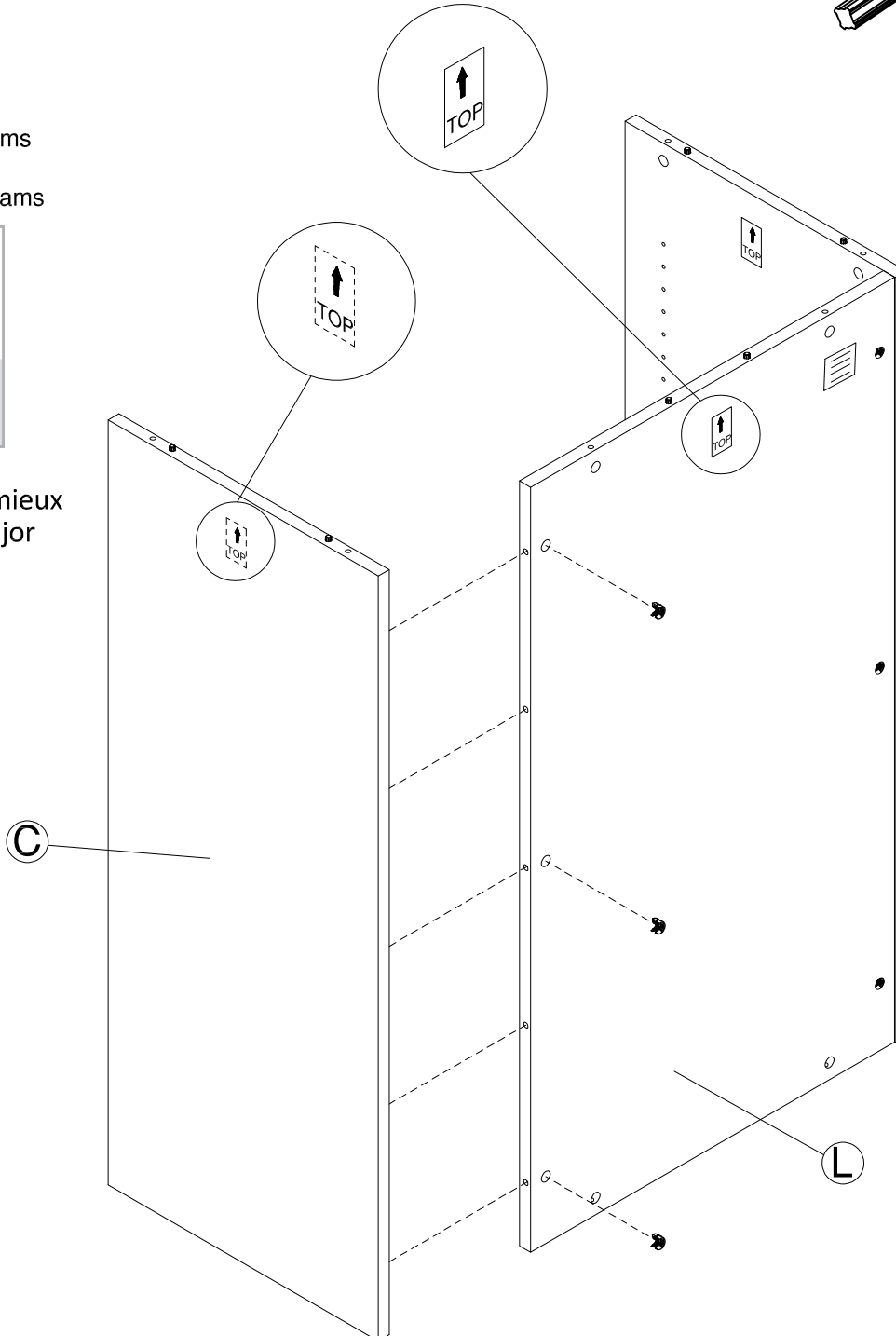
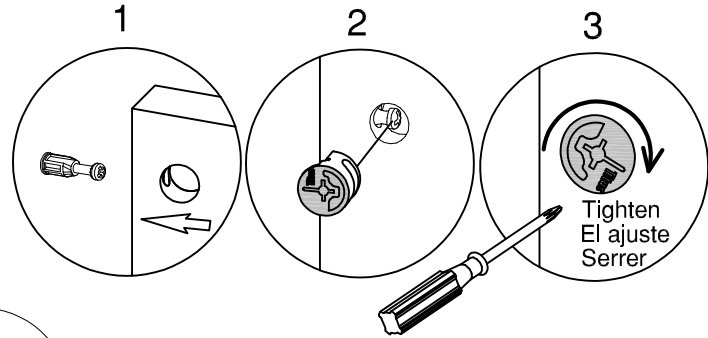

Scan QR Code to
Watch Video on:
Escancódigo QR a
Vea el Video sobre:
Scannez le Code QR pour
Regardez la vidéo sur:



H181468

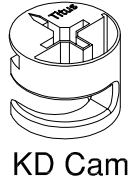

[4]

KD Cam

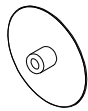

[4]

Cover Cap

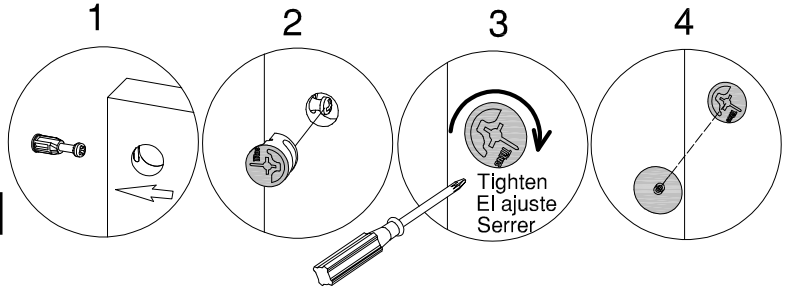

Tighten
El ajuste
Serrer

How to Tighten KD Cams
Cómo apre KD Cams
Comment serrer KD Cams

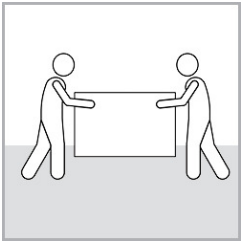

Team Lift

deux personne c'est mieux
dos personas es major

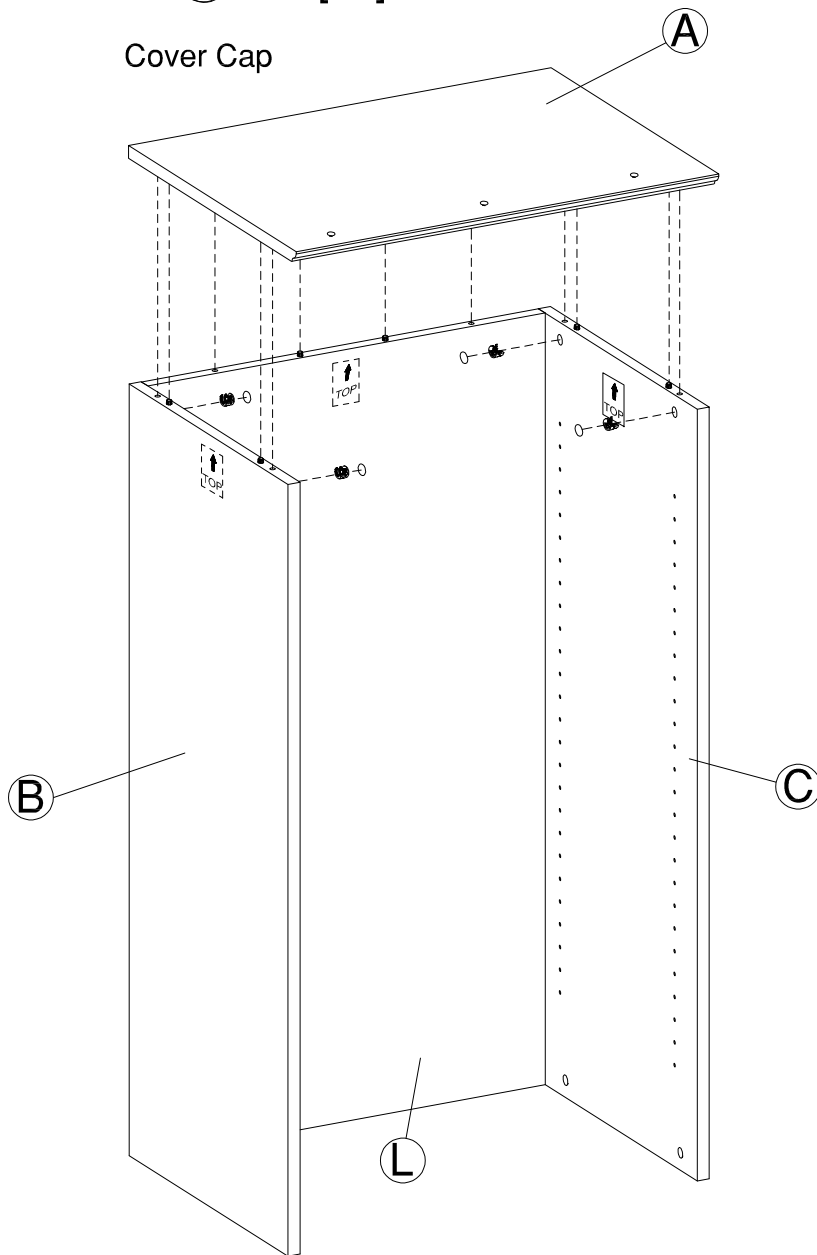

Scan QR Code to
Watch Video on:
Escancódigo QR a
Vea el Video sobre:
Scannez le Code QR pour
Regardez la vidéo sur:



H181468 [4]
KD Cam

[8]
Cover Cap

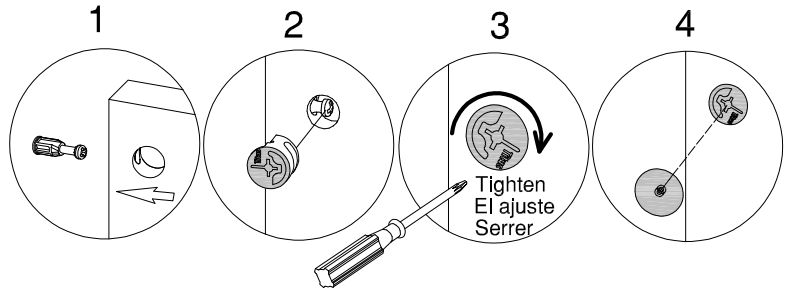

How to Tighten KD Cams
Cómo aprete KD Cams
Comment serrer KD Cams

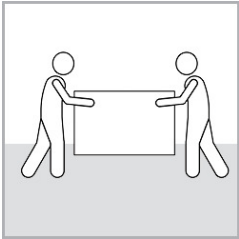

Team Lift

deux personne c'est mieux
dos personas es mejor

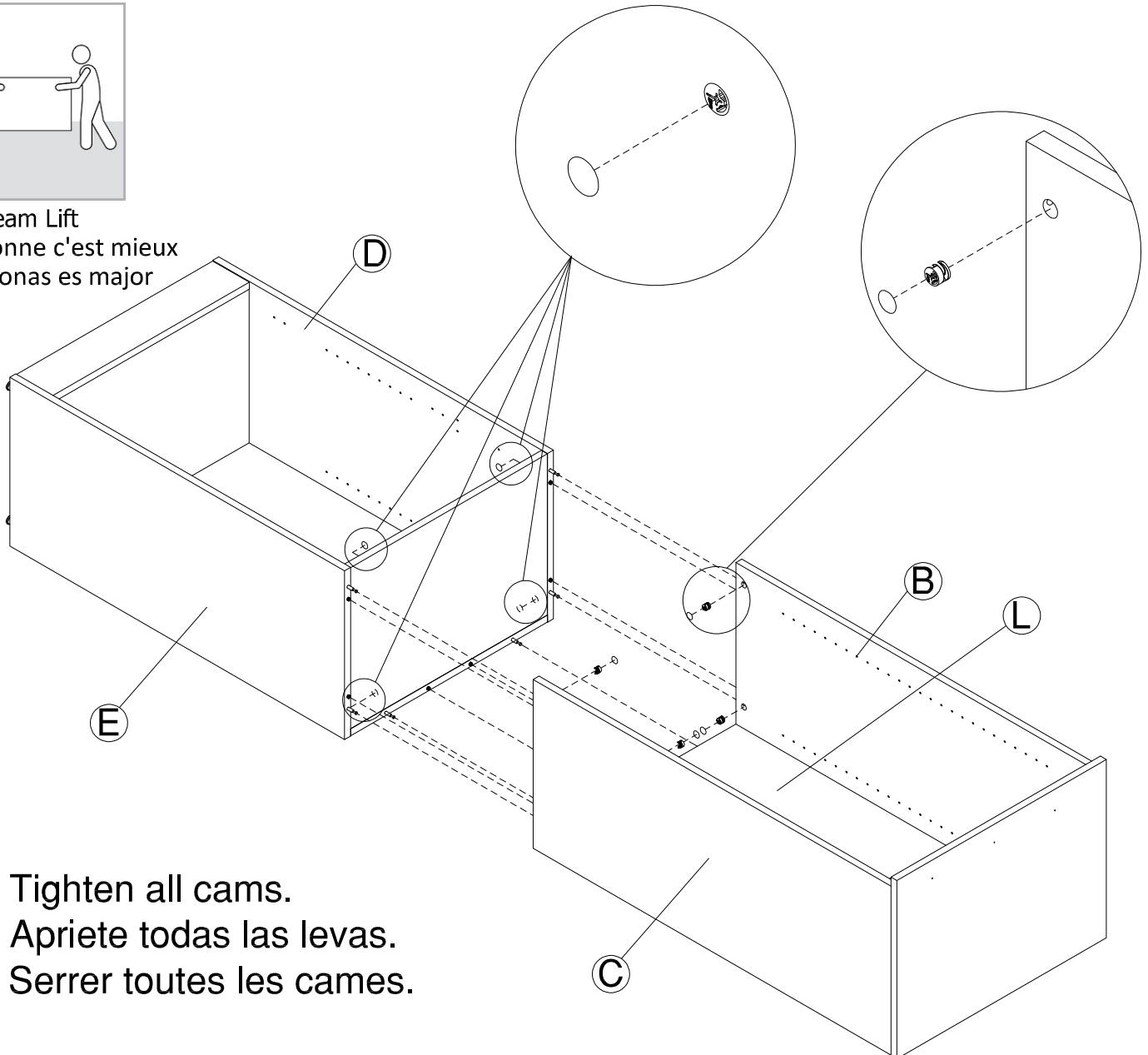

Tighten all cams.
Aprete todas las levas.
Serrer toutes les cames.

Scan QR Code to
Watch Video on:
Escancódigo QR a
Vea el Video sobre:
Scannez le Code QR pour
Regardez la vidéo sur:



H181468

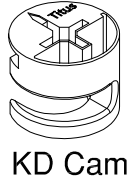

[4]

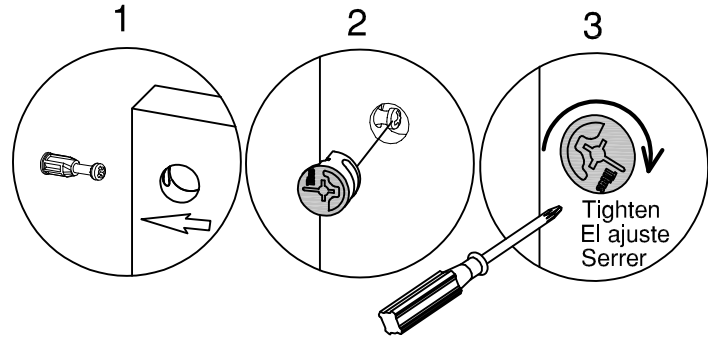

How to Tighten KD Cams
Cómo apre KD Cams
Comment serrer KD Cams

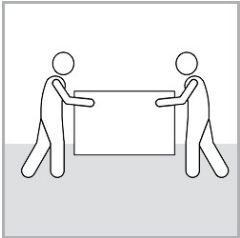

Team Lift

deux personne c'est mieux
dos personas es major

Tighten all cams.
Apriete todas las levas.
Serrer toutes les cames.

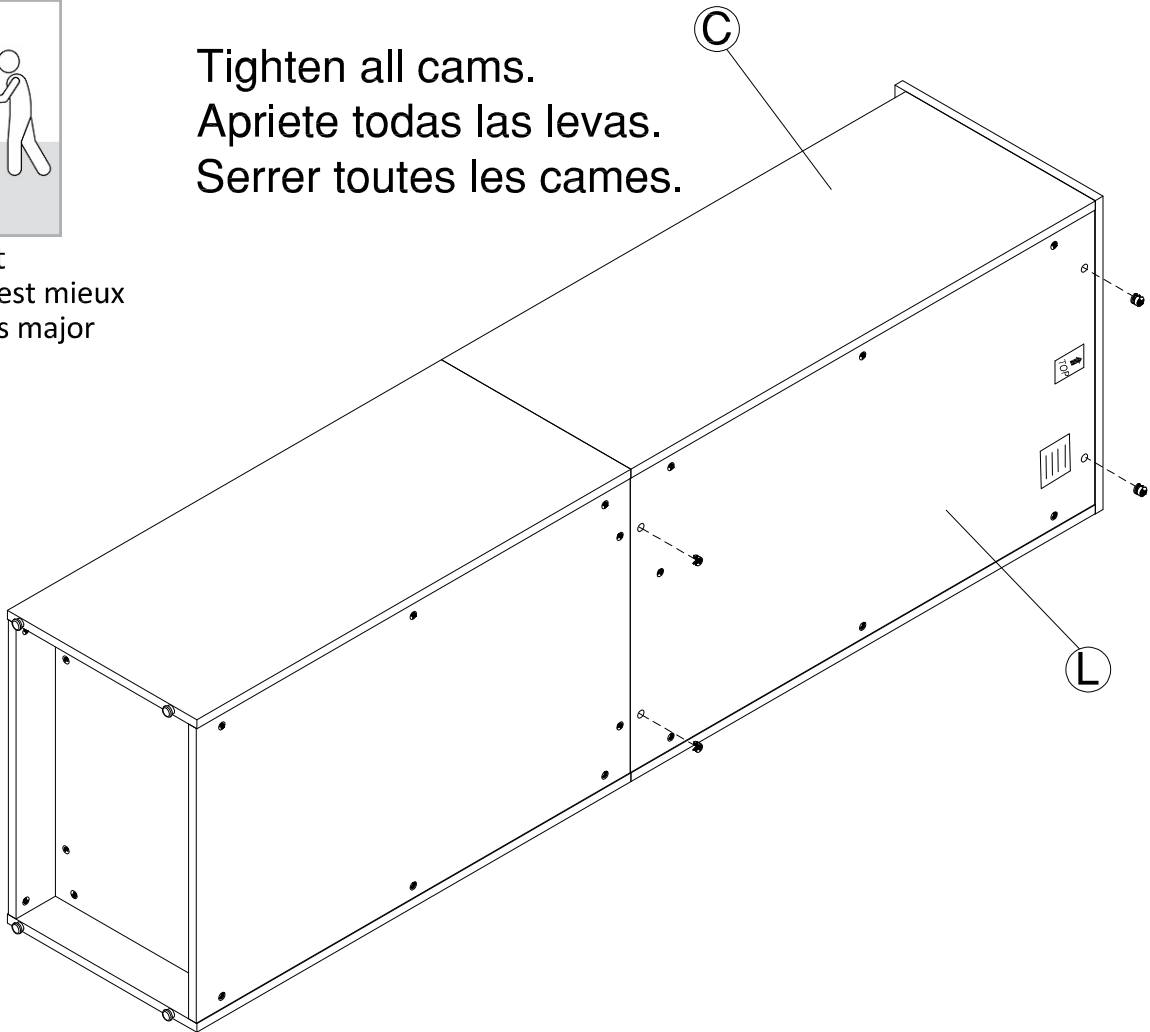

Secure unit to the wall with a tip-over restraint.

Unidad de seguro a la pared con un sistema de retención de un vuelco.

Fixer l'unité au mur avec un dispositif de retenue renversement.

1. Place unit in desired location.
2. Locate wall stud nearest unit center. **FIG A**
3. On wall, mark center of stud location 1" below top of unit. **FIG A**
4. If a wall stud cannot be located mark hollow wall at unit center. **FIG A**
5. On back of unit, mark corresponding location 3/8" below top of unit. **FIG B**

1. Coloque la unidad en el lugar deseado.
2. Localice pie derecho de pared centro de unidad más próxima.
3. En la pared del, marque el centro de la ubicación del montante 1 "abajo la parte superior de la unidad.
4. Si un poste de la pared no se puede localizar marcar pared hueca en el centro de la unidad.
5. En el dorso de la unidad, marque la ubicación 3/8 correspondiente abajo la parte superior de la unidad.

1. Placez l'unité à l'endroit désiré.
2. Localiser centre d'unité la plus proche de la paroi Stud.
3. Sur le mur, centre de emplacement du montant 1 "ci-dessous dessus de l'appareil de la marque.
4. Si un montant de mur ne peut pas être situé marquer mur creux au centre de l'unité.
5. Le dos de l'appareil, marquer l'emplacement 3/8 correspondant ci-dessous dessus de l'appareil.

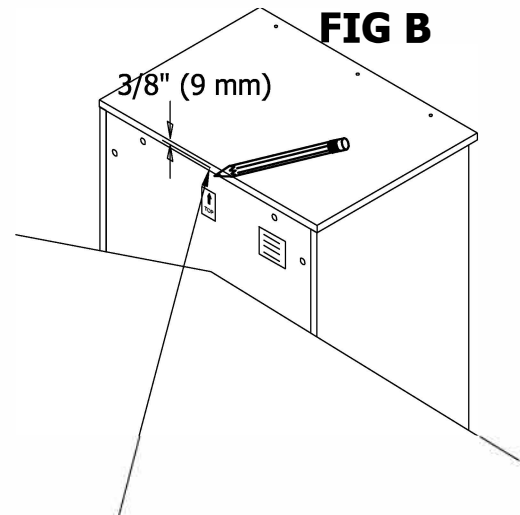
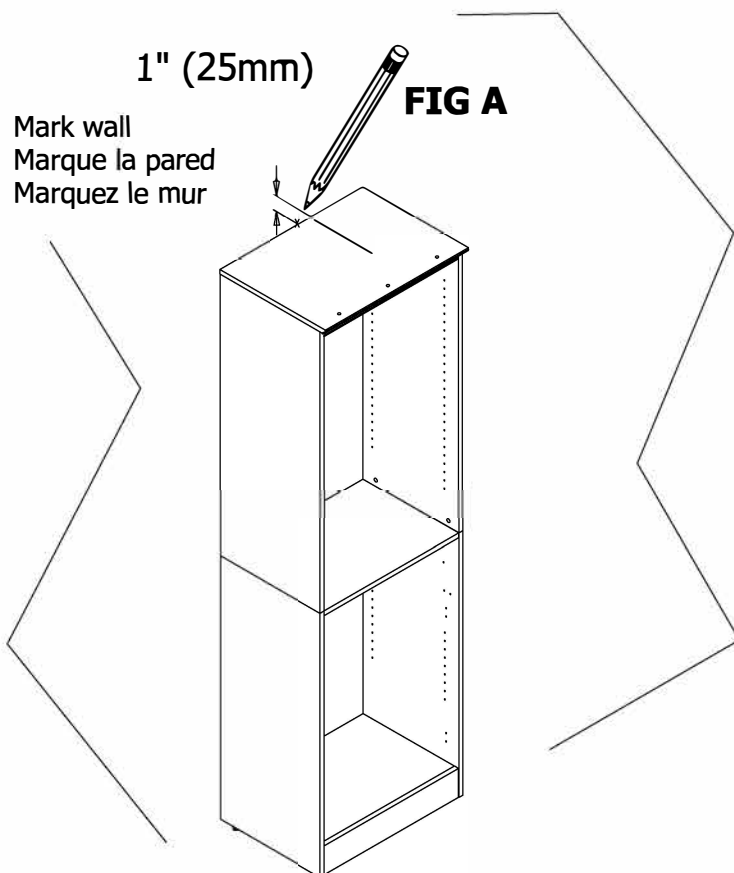

Mark back within 6" (150mm) of center.
Marcar de vuelta dentro de 6" (150mm) de centro
Mark dans les 6" (150mm) de centre.

Properly level your furniture
using the adjustable legs.
Bien niveler votre meuble
en utilisant les patins niveleurs.
Nivele su mueble adecuadamente
utilizando las patas ajustables.

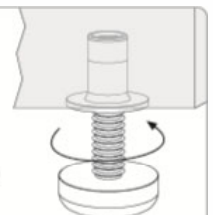

WALL STUD ATTACHMENT

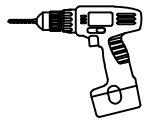

Drill 1/8" hole 2" deep at mark on wall.

Taladro 1/8 "agujero 2" de profundidad en la marca en la pared.

Percer 1/8 "trou de 2" de profondeur à la marque sur le mur.

H181434

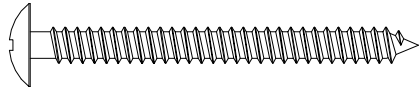

[1]

#10x2"

H181412

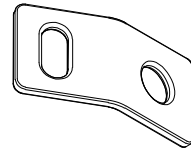

[1]

Connecting Plate

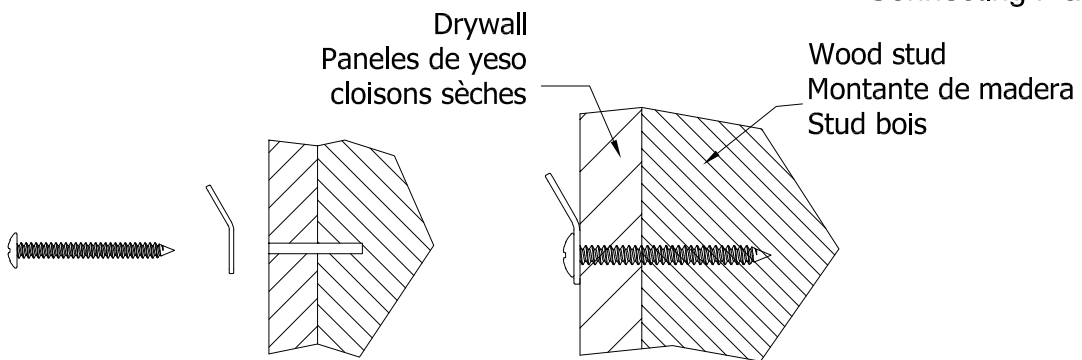

HOLLOW WALL ATTACHMENT

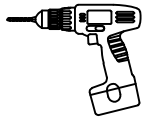

Drill 1/2" hole 1" deep at mark on wall.

Taladro 1/2 "agujero 1" de profundidad en la marca en la pared.

Percer 1/2 "trou de 1" de profondeur à la marque sur le mur.

H181419

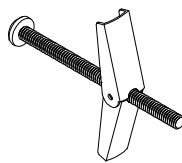

[1]

Toggle Bolt

H181412

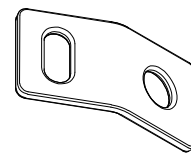

[1]

Connecting Plate

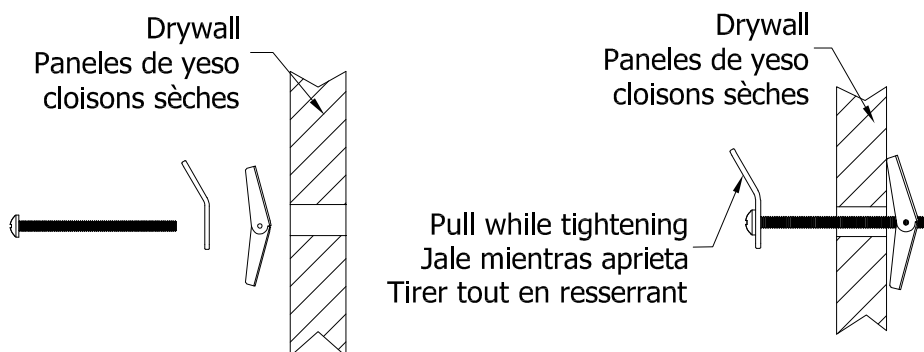

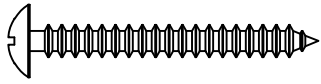
H107572  [1]
#8x1-1/2"

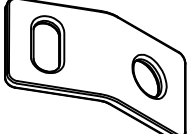
H181412  [1]

Connecting Plate

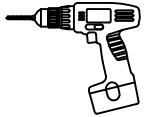

Drill 1/8" hole 1-1/4" deep at mark on unit.
Taladro 1/8 "agujero de 1-1/4" de profundidad en la marca de la unidad.
Perçer 1/8 "trou 1-1/4" de profondeur à la marque sur l'unité.

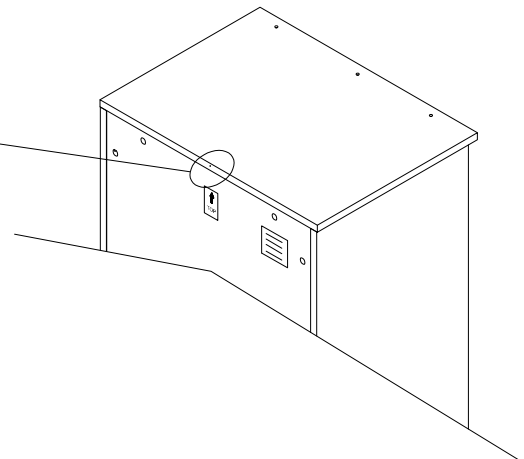
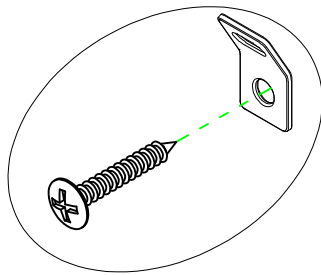

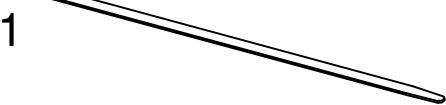
H181411  [1]
Nylon Cable Tie

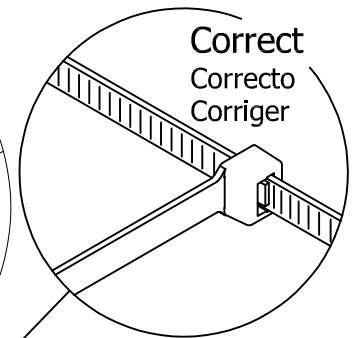
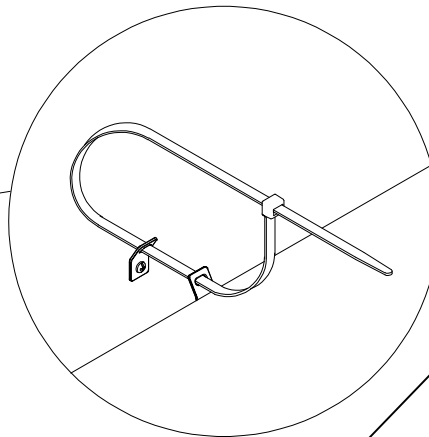
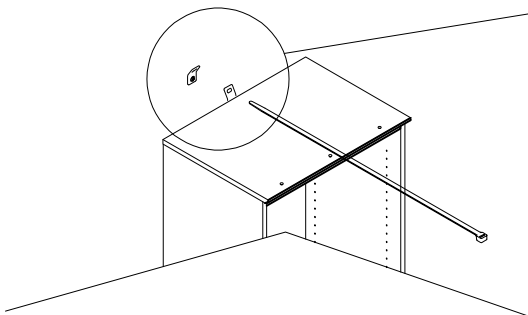

Correct
Correcto
Corriger

Pull to verify lock
Tire para verificar cerradura
Tirez pour vérifier serrure

Use replacement cable tie with minimum breaking strength of 120lbs.
Utilice reemplazo empate Cable con resistencia a la rotura mínima de 120 libras.
Utilisez remplacement Attache de câble avec une force de rupture minimale de 120 lbs.



Team Lift

deux personne c'est mieux
dos personas es major

H23604



[16]

Shelf Pin 1"x 3/16"

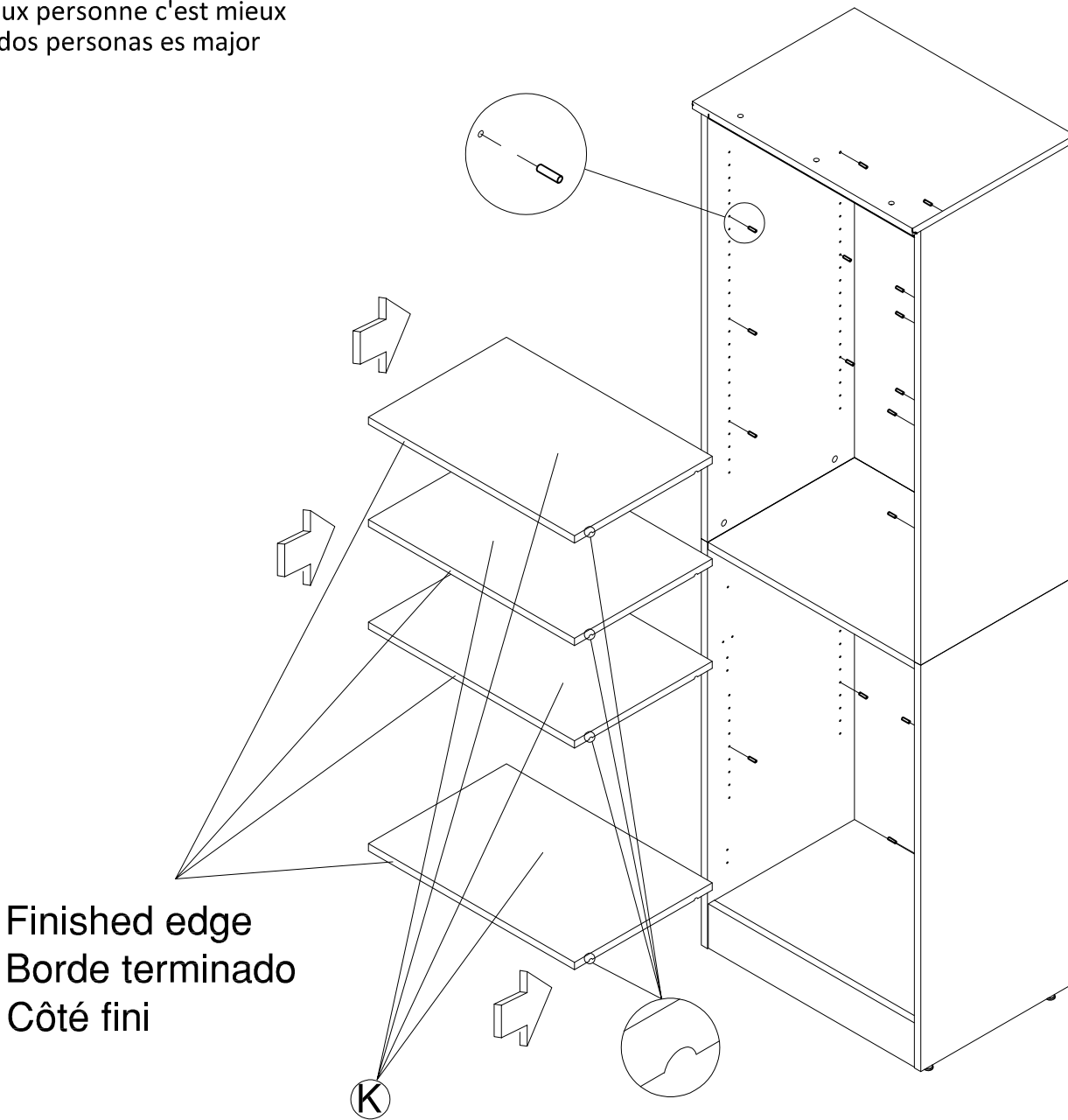

Scan QR Code to
Watch Video on:
Escancódigo QR a
Vea el Video sobre:
Scannez le Code QR pour
Regardez la vidéo sur:



How to Clean the Surface
¿Cómo limpiar la superficie
Comment nettoyer la Surface

Gently clean surfaces
with a damp sponge
eraser.
Nettoyer délicatement
les surfaces avec une
gomme éponge
humide.
Limpie suavemente
las superficies con
una goma de borrar
de esponhúmeda.

MAXIMUM WEIGHT: 0 LBS (0 KG)
PESO MÁXIMO: 0 LIBRAS (0 KILOGRAMO)
POIDS MAXIMUM: 0 LIVRES (0 KILOGRAMME)

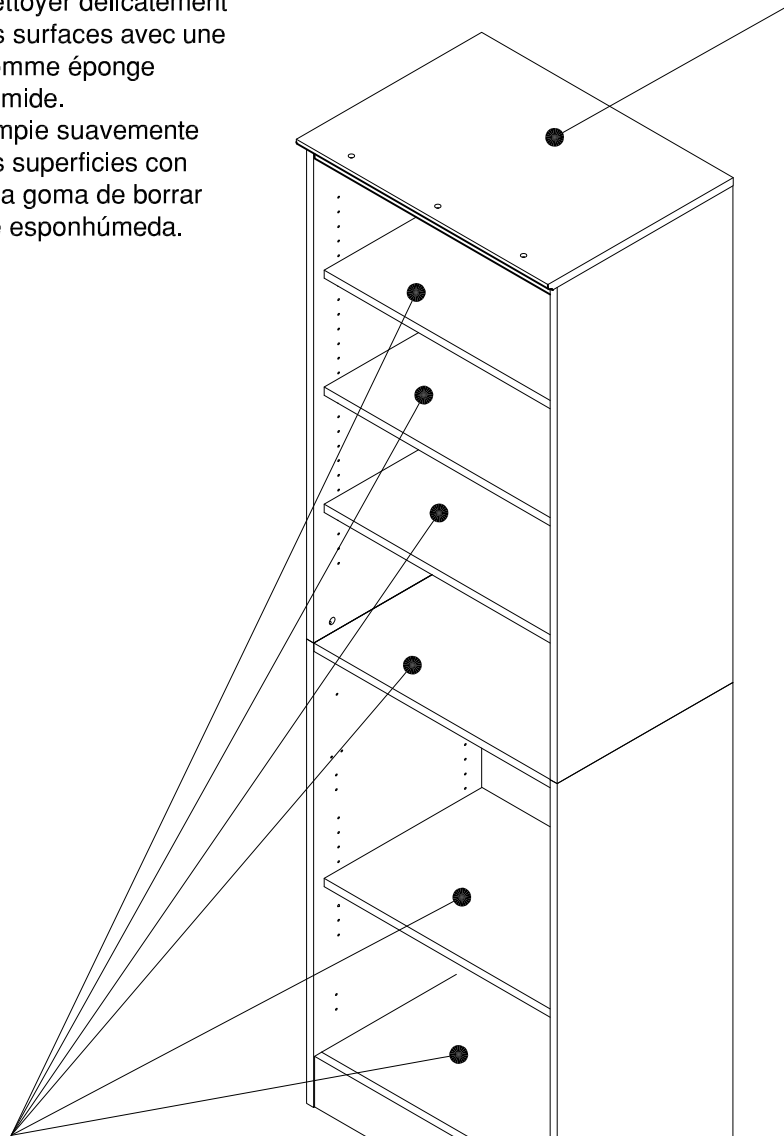

MAXIMUM WEIGHT: 50 LBS (22.68 KG)
PESO MÁXIMO: 50 LIBRAS (22.68 KILOGRAMO)
POIDS MAXIMUM: 50 LIVRES (22.68 KILOGRAMME)

Congratulations! You are all done. If you have any
questions or concerns, please call.
Félicitations! Vous avez terminé. Si vous avez des
questions ou des préoccupations, s' il vous plaît
appelez.
¡Felicitaciones! Todos ustedes han terminado. Si
tiene alguna pregunta o inquietud, por favor llame.

KWS125LW

A	[1]	W212810	G	[1]	W212816
B	[1]	W212811	H	[1]	W212817
C	[1]	W212812	J	[1]	W212818
D	[1]	W212813	K	[4]	W212819
E	[1]	W212814	L	[1]	W212820
F	[1]	W212815	M	[1]	W212821

H200203

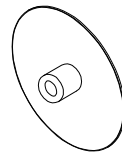

[12]

Cover Cap

H208736



[16]

Cover Cap 5mm

KWS125WT

A	[1]	W212822	G	[1]	W212828
B	[1]	W212823	H	[1]	W212829
C	[1]	W212824	J	[1]	W212830
D	[1]	W212825	K	[4]	W212831
E	[1]	W212826	L	[1]	W212832
F	[1]	W212827	M	[1]	W212833

H192368

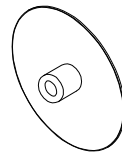

[12]

Cover Cap

H207909



[16]

Cover Cap 5mm

THIS PAGE INTENTIONALLY LEFT BLANK

ESTA PÁGINA INTENCIONALMENTE DEJÓ EN BLANCO

CETTE PAGE EST INTENTIONNELLEMENT LAISSÉE VIDE

THIS PAGE INTENTIONALLY LEFT BLANK

ESTA PÁGINA INTENCIONALMENTE DEJÓ EN BLANCO

CETTE PAGE EST INTENTIONNELLEMENT LAISSÉE VIDE

THIS PAGE INTENTIONALLY LEFT BLANK

ESTA PÁGINA INTENCIONALMENTE DEJÓ EN BLANCO

CETTE PAGE EST INTENTIONNELLEMENT LAISSÉE VIDE