

FMD20

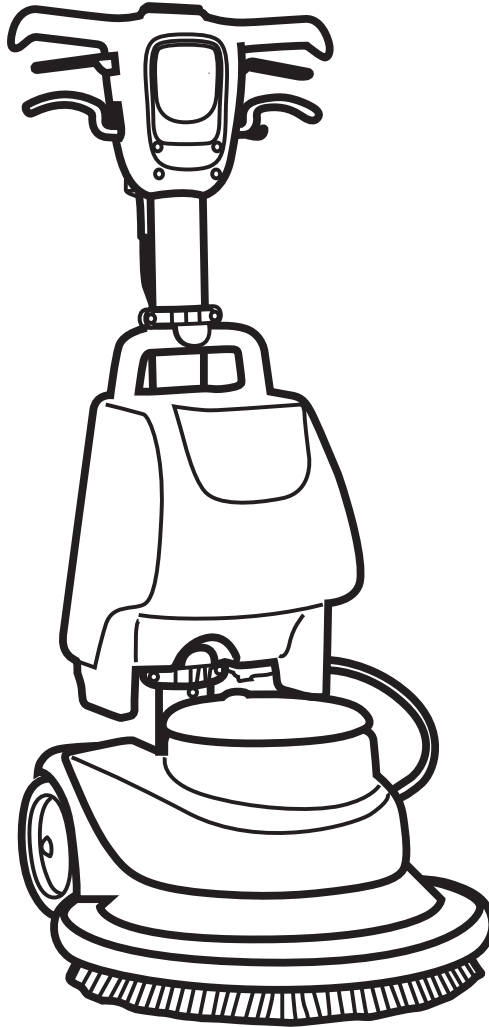

Single disc machine - Monocepillos - Monobrosses

EN SPARE PARTS CATALOGUE
FR CATALOGUE DE PIECES DETACHEES
ES CATALOGO PIEZAS DE REPUESTO

HILLYARD
HILLYARD

TRIDENT®

by HILLYARD



ORIGINAL INSTRUCTIONS DOC. 10076165 - Ver. AC - 03-2021

SUMMARY

SUMMARY	3
RULES	4
PRODUCT STRUCTURE.....	6
HANDLEBAR ASSEMBLY	8
STAND GROUP	12
ENGINE UNIT	14
CARTER GROUP	16
ELECTRIC GROUP.....	18
TANK GROUP.....	20

SOMMAIRE

SOMMAIRE.....	3
RÈGLES.....	4
STRUCTURE DU PRODUIT	6
ENSEMBLE GUIDON	8
GROUPE DE PEUPEMENT	12
UNITÉ DE MOTEUR	14
GROUPE CARTER.....	16
GROUPE DE SYSTÈMES ÉLECTRIQUES.....	18
UNITÉ DE RÉSERVOIR.....	20

ÍNDICE

INDICE	3
REGLAS.....	4
ESTRUCTURA DEL PRODUCTO	6
MONTAJE DEL MANILLAR	8
GRUPO STAND	12
UNIDAD DEL MOTOR	14
GRUPO DE CARROCERÍAS.....	16
GRUPO DE SISTEMAS ELÉCTRICOS.....	18
UNIDAD DEL TANQUE.....	20

EN - The contained descriptions in the present publication are not binding. The Manufacturer therefore reserves itself the right to bring in whatever moment possible organs changes, details or supplies of accessories, that it holds convenient for an improvement, or for any demand of constructive or commercial character. The partial reproduction of the texts and diagrammes contained in the present catalog, is forbidden by law. The Manufacturer reserves itself the right to bring changes of technical character and/or of endowment. The images are meant of pure reference and not binding in terms of design and endowment.

INTRODUCTION:

This catalogue is intended to serve as a guide for the ordering of spare parts and is designed to facilitate rapid identification of the machine in all its versions and to rapid location of its component parts.

HOW TO ORDER:

For the purpose of simplifying stock searching and the delivery of spare parts, we would ask our customers to observe the following standard procedures, at all times specifying:

- The model and part number of the machine;
- The position number and the number of the table of chart in which the parts appear;
- Ordering code and part name;
- Quantity of parts required;
- Precise address and company status of the purchaser placing the order, complete with address for delivery of the goods;
- Shipping means required.

FR - Les descriptions contenu dans la présente publication ne s'entendent pas contraignant. Le Fabriquant donc, il se réserve le droit d'apporter dans n'importe quel moment, les modifications éventuelles à organes, détails, fournitures d'accessoires, qu'elle croit convenables pour une amélioration ou pour n'importe quel exigence de caractère constructif ou commercial.

La reproduction partielle aussi des textes et des dessins, contenu dans le présent catalogue, elle est prohibée aux termes de la loi. Le Fabriquant se réserve le droit d'apporter modifications de caractère technique et/ou de dotation. Les images sont à s'entendre en référence pure et pas contraignants en termes de design et dotation.

INTRODUCTION:

Le présent catalogue a pour but de guider l'utilisateur dans les commandes de pièces détachées. Il a été réalisé pour faciliter une identification rapide de la machine dans toutes ses versions et permet ainsi un repérage rapide de ses composants.

COMMENT PASSER COMMANDE:

Afin de simplifier la recherche dans le magasin et l'expédition des pièces de rechange, nous prions notre clientèle de respecter la procédure suivante en indiquant toujours:

- Le modèle et numéro de la machine;
- Le numéro de la position et numéro du tableau sur lequel figure la pièce;
- La référence et la dénomination;
- La quantité des pièces demandées;
- L'adresse exacte et la raison sociale de l'acheteur qui passe la commande, en indiquant l'adresse de livraison;
- Le moyen de transport désiré (dans le cas où ceci n'est pas précisé l'expéditeur se réserve le droit de choisir le transporteur).

ES - Las descripciones contenidas en la presente publicación no son empeñativas. La Empresa por lo tanto se reserva el derecho de aportar en cualquier momento, eventuales modificaciones a órganos, detalles, suministros de accesorios, que ella crea conveniente para una mejoría o por cualquier exigencia de carácter constructivo o comercial. La reproducción parcial de

los textos y los diseños, contenidos en el presente catálogo, está prohibida por la ley. La Empresa se reserva el derecho a aportar modificaciones de carácter técnico e/o de dotación. Las imágenes son de pura referencia y no vinculantes en términos de diseño y dotación.

INTRODUCCIÓN:

Ese catálogo quiere servir cómo guía para pedir las piezas de repuesto y se ha realizado de manera de consentir una rápida identificación de la máquina en todas sus versiones y por consiguiente una rápida individuación de las piezas que la componen.

MODALIDADES DE LOS PEDIDOS:

Para la búsqueda en el almacén y el envío de las piezas de repuesto, se ruega encarecidamente a los Sres. Clientes de seguir las reglas siguientes y de especificar siempre:

- El modelo y el número de matrícula de la máquina;
- El número de posición y el número de la tabla donde son representadas;
- El código de pedido y la denominación;
- El número de piezas que se desean;
- Las señas exactas y la razón social del Comitente, indicando también las señas eventuales para la entrega de la mercancía;
- El medio de envío que se desea. (En caso de que ese dato no se haya especificado, la Empresa Constructora se reserva el derecho de utilizar a su elección el medio más adecuado.

UPDATES FROM THE PREVIOUS VERSION:

- = This document is valid since the serial number.
- ← = This document is valid till the serial number.

MISE À JOUR DE LA VERSION PRÉCÉDENTE:

- = Document valable à partir du numéro de série.
- ← = Document annulé par le numéro de série.

ACTUALIZACIÓN DE LA VERSIÓN ANTERIOR:

- = Documento válido desde la matrícula n°.
- ← = Documento válido hasta la matrícula n°.

	PAG.	N. DOC.	VER.	SERIAL NUMBER

10075860-AA

00

CR-00 MONOSP HILLYARD TRIDENT FMD20 115V

PRODUCT STRUCTURE TRIDENT FMD20 115V US
 STRUCTURE DU PROD. TRIDENT FMD20 115V US
 PRODUCKTSTRUKTUR TRIDENT FMD20 115V US
 ESTRUCTURA PRODUCT TRIDENT FMD20 115V US

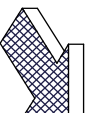
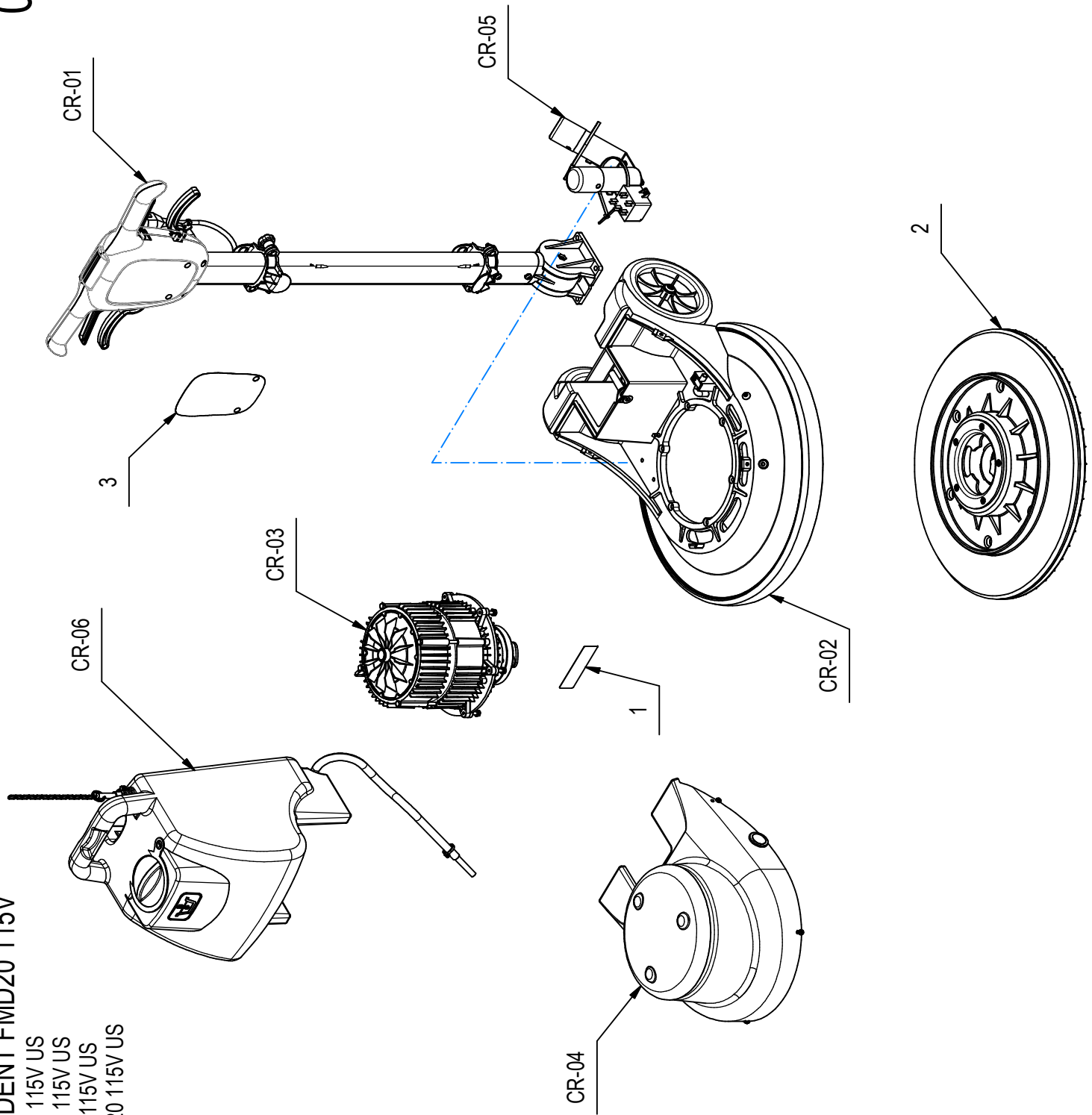

CR-00 MONOSP HILLYARD TRIDENT FMD20 115V

POS	CODICE	QTÀ	DESCRIZIONE	DENOMINATION	DESCRIPTION	BENENNUNG	DESCRIPCION
1	447280	1	ETICHETTA CARTER HILLYARD	DECAL	ETIQUETTE	SCHILD	ETIQUETA
2	405542	1	DISCO TRASCINATORE D=500 ATTACCO WIRBELL	PAD HOLDER	PLATEAU	TREIBTELLER	PORTA-PAD
3	447277	1	ETICH. MAN. OV. TRIDENT FMD 20 HILLYARD	DECAL	ETIQUETTE	SCHILD	ETIQUETA
CR-01	227508	1	GRUPPO MAN. OVAL 16 A 7016 US SNODO ZAMA	HANDLE BAR ASSEMBLY	GRUPE DE TIMON	FÜHRUNGSHOLMGRUPPE	GRUPO MANILLAR
CR-02	223667	1	GRUPPO BASAMENTO S50 RAL7016	BRUSH BASE	EMBASE DES BROSSES	BÜRSTENGESTELL	BANCADA CEPILLOS
CR-03	227821	1	GRUPPO MOTORID. HIQ 1100W 115/60 ACC WIR	GEARED MOTOR	MOTO-REDUCTEUR	GETRIEBEMOTOR	MOTORREDUCTOR
CR-04	227495	1	GRUPPO CARTER S 43 RAL 5012	COVER	CARTER	ABDECKUNG	CARTER
CR-05	227822	1	GRUP. IMP. ELET. S43/50 115/60 HIQ 1100W	ELETRIC COMPONENTS	COMPOSANT ELECTRIQUES	ELEKTROTEILE	COMPONENTES ELECTRICOS
CR-06	224811	1	KIT SERBATOIO MANUB. OVALE PER ORBITALE	TANK	RESERVOIR	TANK	TANQUE

GRUPPO MAN. OVAL 16 A 7016 US SNODO ZAMA

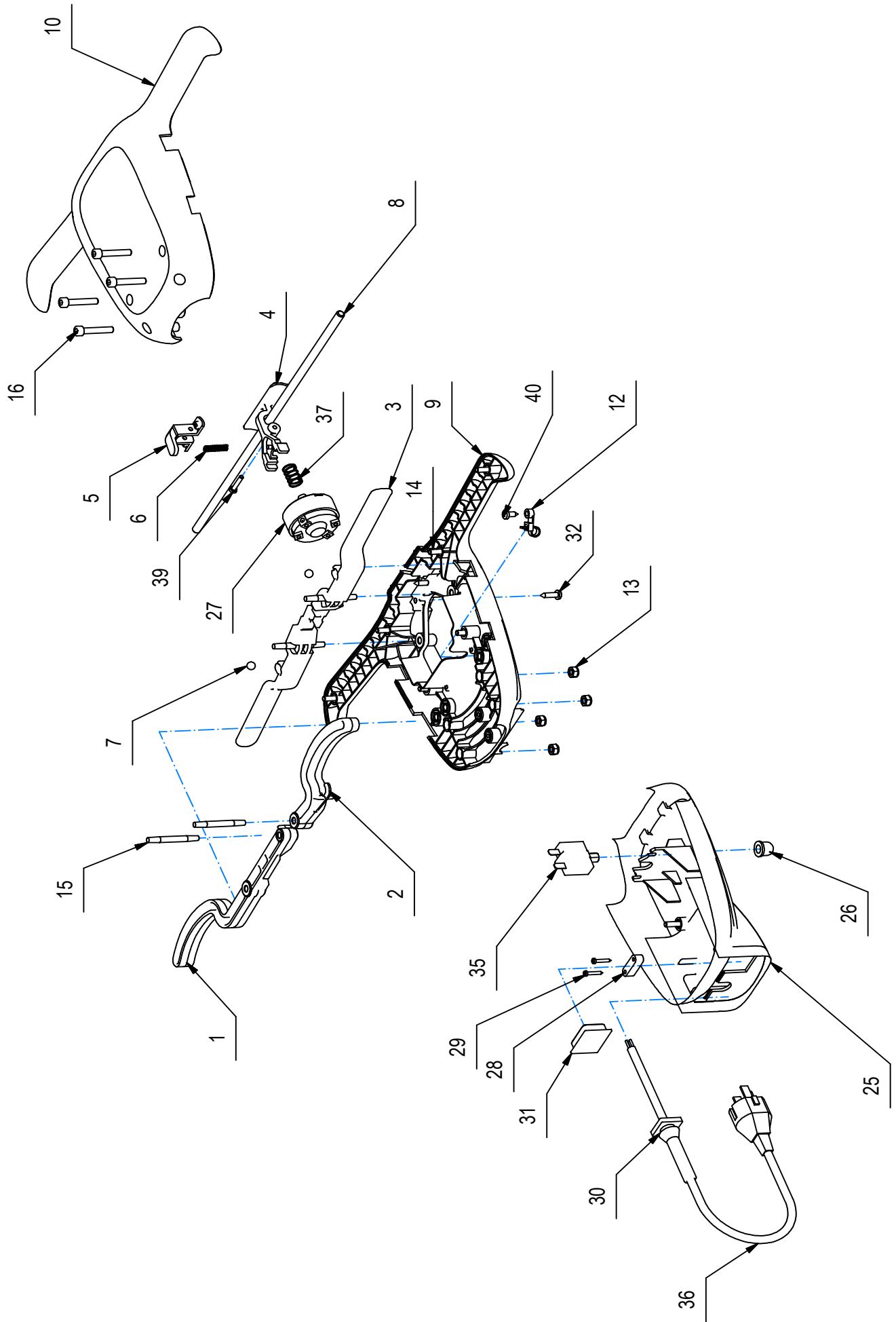

GRUPPO MAN. OVAL 16 A 7016 US SNODO ZAMA

POS	CODICE	QTÀ	DESCRIZIONE	DENOMINATION	DESCRIPTION	BENENNUNG	DESCRIPCION
1	416493	1	LEVA SGANCIO MANUBRIO UNIVERSALE	LEVER	LEVIER	HEBEL	PALANCA
2	416504	1	LEVA RUBINETTO SERBATOIO ECOLAB	LEVER	LEVIER	HEBEL	PALANCA
3	439036	2	LEVA INTERRUITTORE MAN. OVALE RAL 9005	LEVER	LEVIER	HEBEL	PALANCA
4	401122	1	LEVA DI BLOCCO	LEVER	LEVIER	HEBEL	PALANCA
5	416501	1	STAFFA MOLLA	SUPPORT	ATTAQUE	HALTERUNG	SOPORTE FIJADOR
6	416723	1	MOLLA LEVA DI BLOCCO	SPRING	RESSORT	FEDER	RESORTE
7	416768	2	SFERA DIAM8	BALL	BILLE	KUGEL	ESFERA
8	439037	1	TONDINO RINFORZO ZINCATO	REINFORCEMENT	REINFORCEMENT	VERSTÄRKUNG	REFUERZO MANILLAR
9	439034	1	CORPO MANUBRIO OVALE RAL 7016 PANT.432 C	HANDLE BAR BODY	CORPS DE TIMON	FÜHRUNGSHOLMKÖRPER	CUERPO MANILLAR
10	439033	1	COPERCHIO MAN. OVALE RAL 7016 PANT. 432C	HANDLE BAR COVER	COUVERCLE DE TIMON	DECKEL FÜHRUNGSHOLM	TAPA MANILLAR
11	223753	1	TUBO PER MANUBRIO OVALE	PIPE	TUBE	ROHR	TUBO
12	416828	1	FASCETTA PL.4,8X200 - OCC.D.5 RUFFO	CLAMP	COLLIER	BRIDE	ABRAZADERA
13	409082	7	DADO M6x6 AUTOBL UNI 7474 ZINC	LOCK NUT	ECROU AUTOFREINES	SICHERUNGSMUTTER	TUERCA AUTOBLOCCANTE
14	408506	9	VITE D.5X20 AUTOF. POLI LOCK	SCREW	VIS	SCHRAUBE	TORNILLO
15	438804	4	SPINA D.6 L.57 OTTONE	SPRING PIN	FOURCHETTE	SPANNSTIFT	PASADOR ELASTICO
16	408799	4	VITE M6X35 TCEI UNI 5931	SCREW	VIS	SCHRAUBE	TORNILLO
17	409164	2	ROSETTA GROWER 6x2,5x1,8 ASA B27 ZINC	LOCK WASHER	RONDELLE FREIN	ZAHNSCHEIBE	ARANDELLA DENTADA
18	409382	1	COPIGLIA D2 X20 UNI 1336	SPLIT PIN	GOUPILLE	SPLINT	PASADOR DE ALETAS
19	416494	1	ASTA SGANCIO MANUBRIO A SCATTI	ROD	TIGE	STANGE	VARILLA
20	437631	4	STAFFA SUPPORTO SERBATOIO ANTRISTRAPPO	SUPPORT	ATTAQUE	HALTERUNG	SOPORTE FIJADOR
21	409156	2	ROSETTA 6x12x1,6 UNI 6592 ZINC	WASHER	RONDELLE	UNTERLAGSCHEIBE	ARANDELA
22	410230	1	POMELLO VB30 M6	KNOB	POMMEAU	RENDELSCHRAUBE	POMO
23	416820	1	PASSACAVO PER FORO D.25 D _i =15	FAIRLEAD	PASSE-CABLE	KABELDURCHGANG	GUIACABLE
24	416672	1	TUBO VITREO S43 D=10 L=640	HOSE	TUYAU	SCHLAUCH	TUBO DE GOMA
25	439035	1	SPORTELLIO MAN. OVALE RAL 7016 PANT. 432C	REAR DOOR	PORTILLON ARRIERE	RÜCKWAND	PORTEZUELA TRASERA
26	416817	1	CAPPUCCIO DISGIUNTORE	PROTECTION CAP	CALOTTE DE PROTECTION	SICHERHEITSKAPPE	CAPUCHO DE PROTECCION
27	416811	1	INTERRUPTORE AVVIAMENTO	SWITCH	INTERRUPTEUR	SCHALTER	INTERRUPTOR
28	409765	1	PRESSACAVO A PONTICELLO	CABLE GRIP	PRESSE-ETOUIPE	KABELVERSCHRAUBUNG	RACOR CABLE
29	418269	2	VITE D.2,9x19 AUTOF. ZINC UNI 6954	SELF-TAPPING SCREW 2,9x19 TC T.C. ZNT	VIS	SCHRAUBE	TORNILLO

GRUPPO MAN. OVAL 16 A 7016 US SNODO ZAMA

HANDLEBAR ASSEMBLY
 ENSEMBLE GUIDON
 LENKERMONTAGE
 MONTAJE DEL MANILLAR

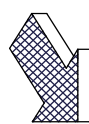
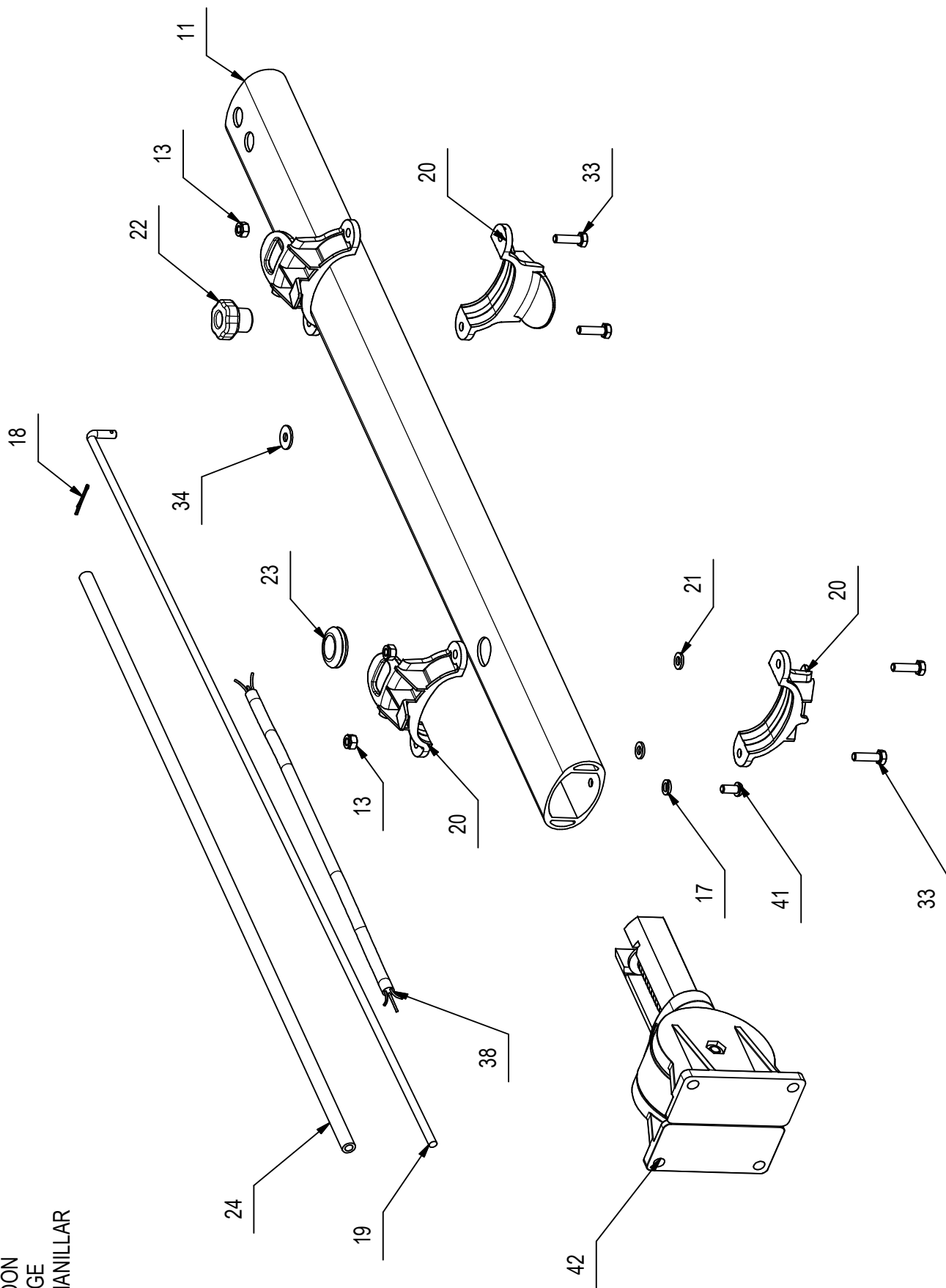

GRUPPO MAN. OVAL 16 A 7016 US SNODO ZAMA

POS	CODICE	QTÀ	DESCRIZIONE	DENOMINATION	DESCRIPTION	BENENIUNG	DESCRIPCION
30	417828	1	PASSACAVO NERO	FAIRLEAD	PASSE-CABLE	KABELDURCHGANG	GUIA/CABLE
31	418164	1	TAPPO PRESETTA PICCOLO	CAP	CAPUCHON	KAPPE	TAPON
32	416787	2	VITE D.4,8x19 AUTOF. UNI 7981 DERK	SCREW	VIS	SCHRAUBE	TORNILLO
33	407666	4	VITE M6X20 TE UNI 5739 ZINC	SCREW	VIS	SCHRAUBE	TORNILLO
34	409160	1	ROSETTA 6x18x1,5 UNI 6593 ZINC	WASHER	RONDELLE	UNTERLAGSCHEIBE	ARANDELA
35	416808	1	DISGIUNTORE DI SIC. 16A	CONTACT BREAKER	DISJONCTEUR	AUFTRENNER	DISYUNTOR MECANICO
36	440567	1	CAVO AWG 3x14x500 115V SPINA USA	CABLE	CABLE	KABEL	CABLE
37	440824	1	MOLLA COMPRESSIONE H.20 x Di.11.6x SP.1	SPRING	RESSORT	FEDER	RESORTE
38	441024	1	CAVO AWG 3X14X1680 MASSA FAST.(PER 115V)	CABLE	CABLE	KABEL	CABLE
39	408634	1	VITE M4x20 TE UNI 5739 ZINC	SCREW	VIS	SCHRAUBE	TORNILLO
40	416789	1	VITE D.4,8x13 AUTOF. UNI 7981 DERK	SCREW	VIS	SCHRAUBE	TORNILLO
41	416777	2	VITE M6x12 TBEI UNI7380 ZN	SCREW	VIS	SCHRAUBE	TORNILLO
42	204491	1	PREM. SNODO MANUBRIO FINE CORSA	JOINT ASSY	GRUPE DE JOINT	GELENK GRUPPE	GRUPO ARTICULATION

CR-02 GRUPPO BASAMENTO S50 RAL 7016

BRUSHES BASE ASSEMBLY
 GROUPE PLATEAU DES BROSSES
 GRUPPE BÜRSTENGESTELL
 GRUPO BANCADA CEPILLOS

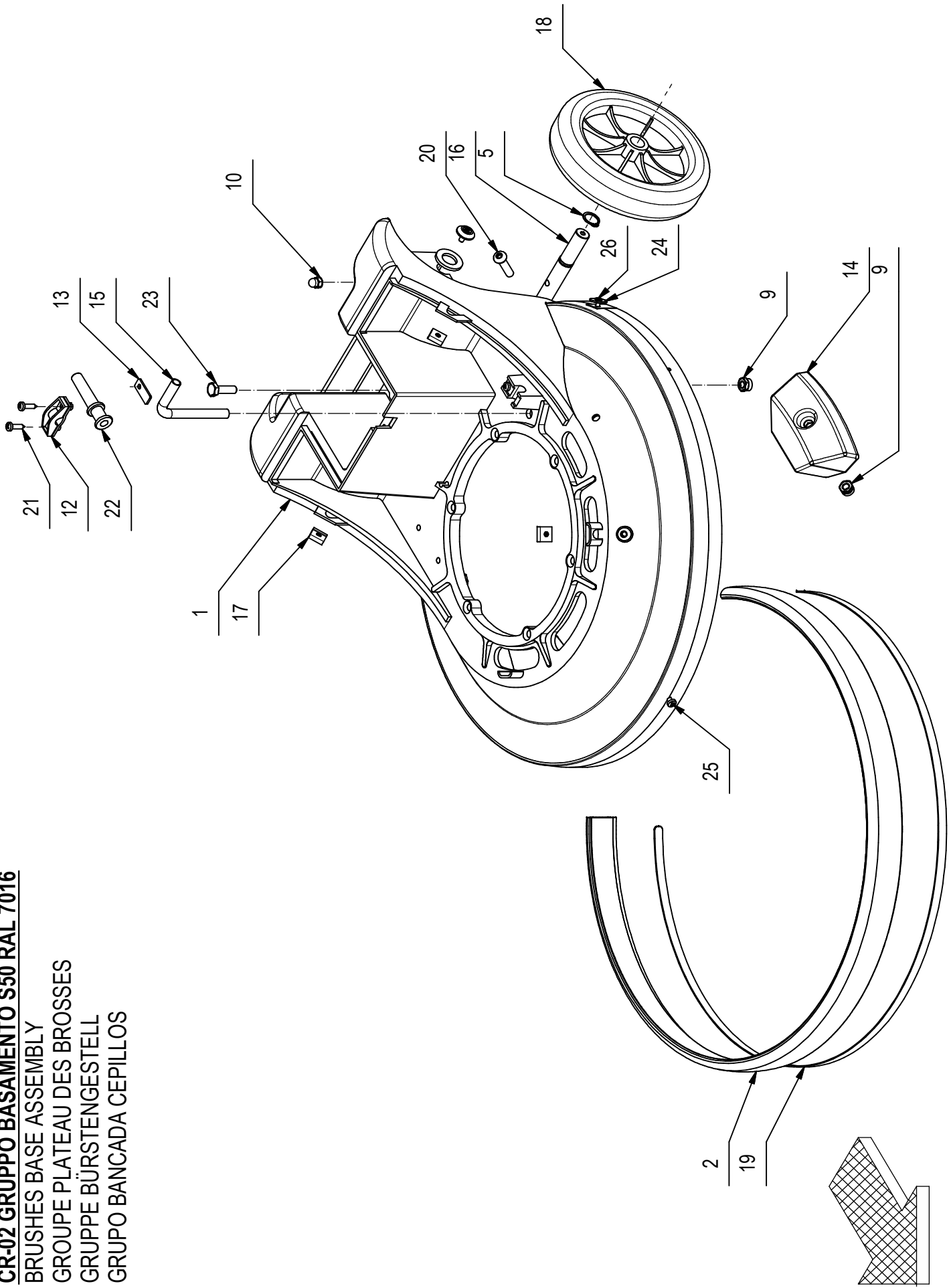

CR-02 GRUPPO BASAMENTO S50 RAL 7016**02**

POS.	CODICE	QTÀ	DESCRIZIONE	DENOMINATION	DESCRIPTION	BENENNUNG	DESCRIPCION
1	204401	1	CORPO BASAMENTO MONOSPAZZOLA S50 RAL7016	BRUSH BASE	EMBASE DES BROSSES	BÜRSTENGESTELL	BANCADA CEPILLOS
2	204446	1	PROFILO PARAURTI L=1210 S50	BUMPER	BUTEE	PUFFER	PARACHOQUES
5	408350	2	SEEGER E 16 X1 DIN 471	SEEGER RING	SERRE CLIPS	SEEGERRING	ANILLO SEEGER
9	409085	6	DADO M8x8.5 AUTOBL. UNI 7474 ZINC	LOCK NUT	ECROU AUTOFREINES	SICHERUNGSMUTTER	TUERCA AUTOBLOCANTE
10	409107	2	DADO M6 CIECO CON CALOTTA UNI 5721 INOX	DOMED CAP NUT	ECROU BORGNE	HUTMUTTER	TUERCA
12	409756	1	FISSACAVO LAGO	CABLE FASTENER	FIXAGE DE CABLE	KABELBEFESTIGUNG	BRIDA CABLE
13	416406	1	PIASTRINA FISSAGGIO TUBO	PLAQUE	PLAQUETTE	BEFESTIGUNGSAUFLAGE	PLAQUETA
14	416412	1	CONTRAPPESO S43	COUNTER WEIGHT	CONTREPOIDS	GEGENGEWICHT	CONTRAPESO
15	416414	1	TUBO USCITA ACQUA S43	PIPE	TUBE	ROHR	TUBO
16	416471	1	PERNO RUOTA S43	PIN	AXE	BOLZEN	PERNO
17	416510	4	PIASTRINA FISSAGGIO CARTER S43	PLAQUE	PLAQUETTE	BEFESTIGUNGSAUFLAGE	PLAQUETA
18	416667	2	RUOTA D=175 NUCLEO TERMOPLASTICO	WHEEL	ROUE	RAD	RUEDA
19	416729	1	MOLLA FISSAGGIO GOMMA PARAURTI S50	SPRING	RESSORT	FEDER	RESSORTE
20	416779	1	VITE M8x35 TBEI ISO 7380 ZINC	SCREW	VIS	SCHRAUBE	TORNILLO
21	416787	3	VITE D.4.8x19 AUTOF. UNI 7981 DERK	SCREW	VIS	SCHRAUBE	TORNILLO
22	416818	1	PASSACAVO D=8,6	FAIRLEAD	PASSE-CABLE	KABELDURCHGANG	GUIACABLE
23	408674	4	VITE M8x25 TE UNI 5739 ZINC	SCREW	VIS	SCHRAUBE	TORNILLO
24	409160	2	ROSETTA 6x18x1,5 UNI 6593 ZINC	WASHER	RONDELLE	UNTERLAGSCHEIBE	ARANDELA
25	416788	1	VITE D.4.8x9,5 AUTOF. UNI 7981 DERK	SCREW	VIS	TORNILLO	SCHRAUBE
26	416791	2	VITE M4x20 TPSTC UNI7688 ZINC	SCREW	VIS	SCHRAUBE	TORNILLO
27	409078	2	DADO M4x6 AUTOBL. UNI 7473 ZINC	LOCK NUT	ECROU AUTOFREINES	SICHERUNGSMUTTER	TUERCA AUTOBLOCANTE
28	408516	2	VITE M5x16 TSCTC UNI 7689 ZINC	SCREW	VIS	SCHRAUBE	TORNILLO
29	400250	2	ROSETTA SOTTOVITE D=5X20	SPECIAL WASHER	RONDELLE SPECIALE	UNTERLAGSCHEIBE SPEZIAL	ARANDELA ESPECIAL
30	415859	1	VITE M8x16 TBEI ISO 7380 ZINC	SCREW	VIS	SCHRAUBE	TORNILLO
31	409175	1	ROSETTA 8x17x1,6 UNI 6592 ZINC.	WASHER	RONDELLE	UNTERLAGSCHEIBE	ARANDELA
32	408659	2	VITE M6x30 TE UNI 5739 ZINC	SCREW	VIS	SCHRAUBE	TORNILLO
33	409217	2	ROSETTA 17x30x3 UNI 6592 ZINC	WASHER	RONDELLE	SCHIBE	ARANDELA

GRUPPO MOTORID. HIQ 1100W 115/60 ACC WIR

GEARMOTOR UNIT

UNITE' MOTOREDUCTEUR

GETRIEBEEINHEIT

UNIDAD DEL MOTORREDUCTOR

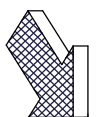
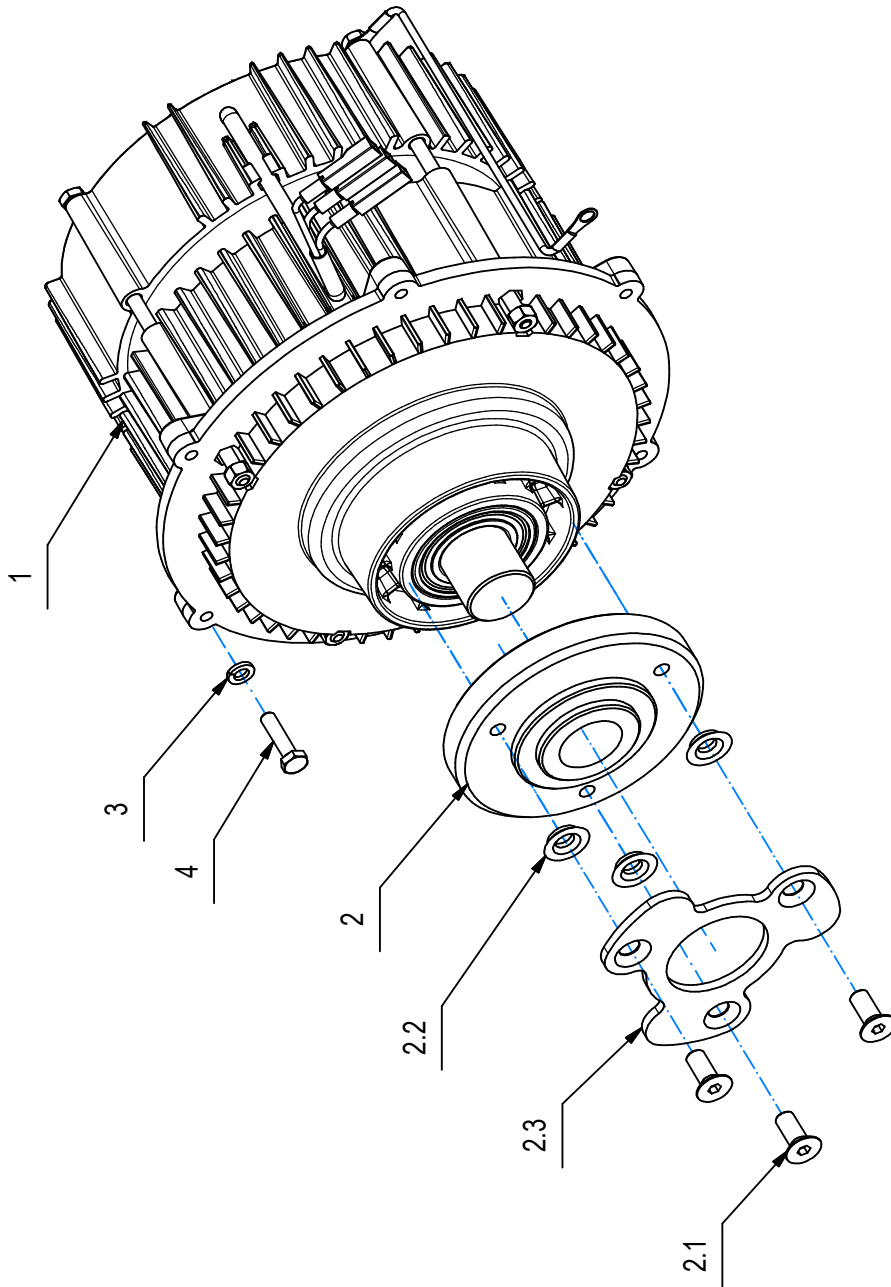

GRUPPO MOTORID. HIQ 1100W 115/60 ACC WIR

POS	CODICE	QTA	DESCRIZIONE	DENOMINATION	DESCRIPTION	BENENNUNG	DESCRIPCION
1	227788	1	KIT MOTORID. HIQ ACCIAIO 1100W 115V 60HZ	GEARMOTOR UNIT	UNITE' MOTOREDUCTEUR	GETRIEBEEINHEIT	UNIDAD DEL MOTORREDUCTOR
2	223325	1	FLANGIA WIRBELL HIQ (LAVORAZIONE)	FLANGE	FLASQUE	FLANSCH	BRIDA
2.1	415833	3	VITE TPSEI M8x20 UNI5933	SCREW	VIS	SCHRAUBE	TORNILLO
2.2	204329	3	DISTANZIALE ATTACCO SPAZZOLA	SPACER	ENTRETOISE	DISTANZHUELSE	DISTANCIADOR
2.3	206829	1	FLANGIA DI ATTACCO SPAZZOLA	FLANGE	FLASQUE	FLANSCH	BRIDA
3	409164	6	ROSETTA GROWER 6x2,5x1,8 ASA B27 ZINC	LOCK WASHER	RONDELLE FREIN	ZAHNSCHEIBE	ARANDELLA DENTADA
4	407669	6	VITE M6x25 TE UNI 5739 ZINC	SCREW	VIS	SCHRAUBE	TORNILLO

GRUPPO CARTER S 43 RAL 5012

CARTER GROUP S43 RAL 5012

CARTER GROUP S43 RAL 5012

CARTER GRUPPE S43 RAL 5012

GRUPO CARTER S43 RAL 5012

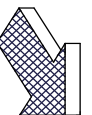
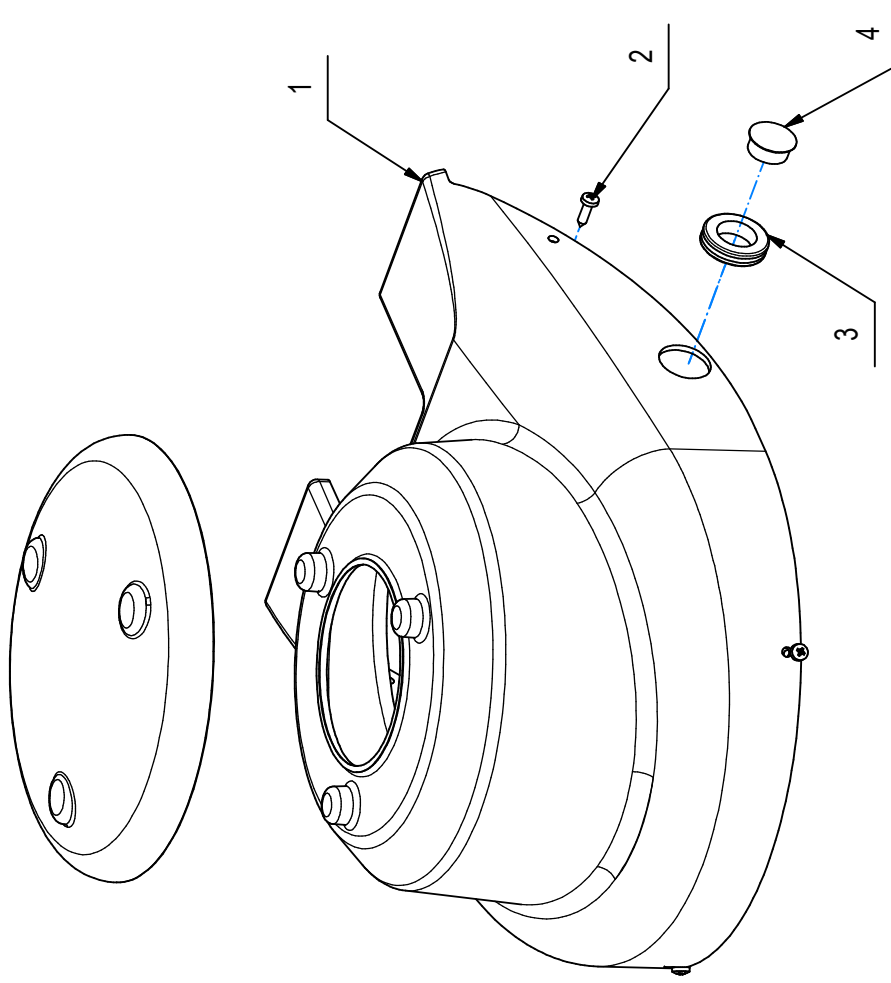

GRUPPO CARTER S 43 RAL 5012

POS	CODICE	QTÀ	DESCRIZIONE	DENOMINATION	DESCRIPTION	BENENNUNG	DESCRIPCION
1	416533	1	CARTER MOTORE S43 RAL5012 FIMAP	COVER	CARTER	ABDECKUNG	CARTER
2	416787	4	VITE D.4,8x19 AUTOF. UNI 7981 DERK	SCREW	VIS	SCHRAUBE	TORNILLO
3	409815	1	PASSAFILO DIAM.26X22X2	FAIRLEAD	PASSE-CABLE	KABELDURCHGANG	GUIACABLE
4	416821	1	TAPPO KSS HP22	PLUG	BOUCHON	STOPFEN	TAPON

GRUP. IMP. ELET. S43/50 115/60 HIQ 1100W

ELETRIC GROUP
GROUP ELETRIQHE
ELETRIC GROUP
GRUPO ELECTRICO

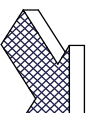
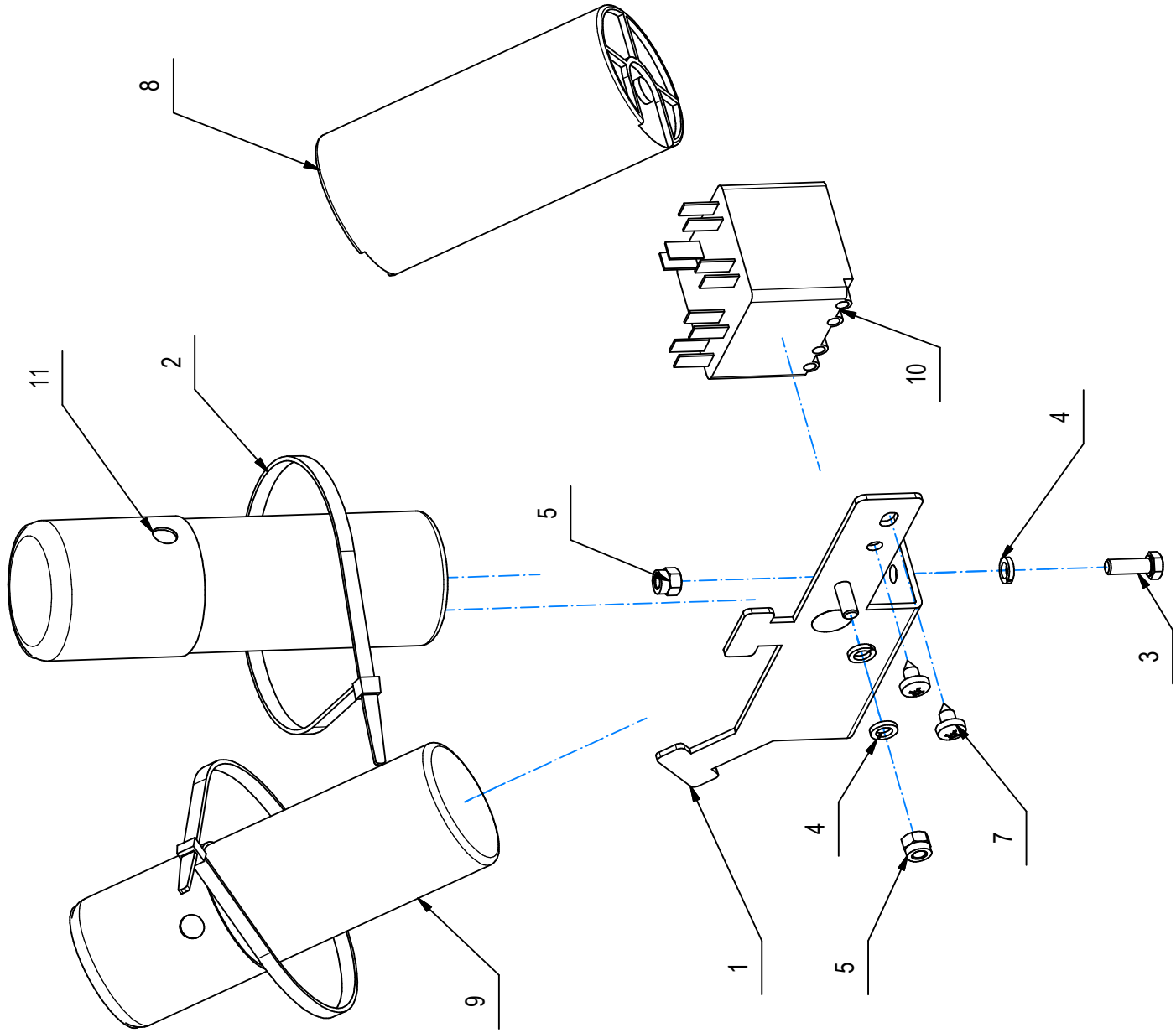

GRUP. IMP. ELET. S43/50 115/60 HIQ 1100W

POS	CODICE	QTA	DESCRIZIONE	DENOMINATION	DESCRIPTION	BENENNUNG	DESCRIPCION
1	416544	1	STAFFA CONDENSATORI S43	BRACKET	SUPPORT	HALTERUNG	SOPORTE
2	416829	2	FASCETTA PLASTICA 4.8x290	CLAMP	COLLIER	BRIDE	ABRAZADERA
3	416431	2	VITE M5x14 TE UNI 5739 ZINC	SCREW	VIS	SCHRAUBE	TORNILLO
4	409154	4	ROSETTA GROWER 5x1,6 ZINC	WASHER	RONDELLE	UNTERLAGSCHEIBE	ARANDELA
5	409080	3	DADO M5x7 AUTOBL. UNI 7473 ZINC	LOCK NUT	ECROU AUTOFREINES	SICHERUNGSMUTTER	TUERCA AUTOBLOCANTE
6	416649	1	ETICHETTA CAVI MASSA D=13	DECAL	ETIQUETTE	SCHILD	ETIQUETA
7	416788	2	VITE D.4,8x9,5 AUTOF. UNI 7981 DERK	SCREW	VIS	TORNILLO	SCHRAUBE
8	436777	1	COND. DI AVV. 324-389MF 110 V	CONDENSER	CONDENSATEUR	KONDENSATOR	CONDENSADOR
9	421950	2	CONDENSATORE DI LAV. 80MF 250V 50/60HZ	CONDENSER	CONDENSATEUR	KONDENSATOR	CONDENSADOR
10	416813	1	KLIXON 115V	KLIXON 115V	KLIXON 115V	KLIXON 115V	KLIXON 115V
11	416852	2	CAPPUCCIO CONDENSATORE D.45 H.50	PROTECTION CAP	CALOTTE DE PROTECTION	SICHERHEITSKAPPE	CAPUCHO DE PROTECCION

CR-08 GR. SERBATOIO TOR43 (OPZIONALE)
 GROUP TANK (OPTIONAL)
 GROUPE DE RESERVOIR (OPTION)
 GROUP TANK (OPTIONAL)
 GRUPO DE TANQUE (OPCIONAL)

08

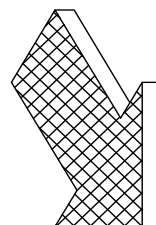
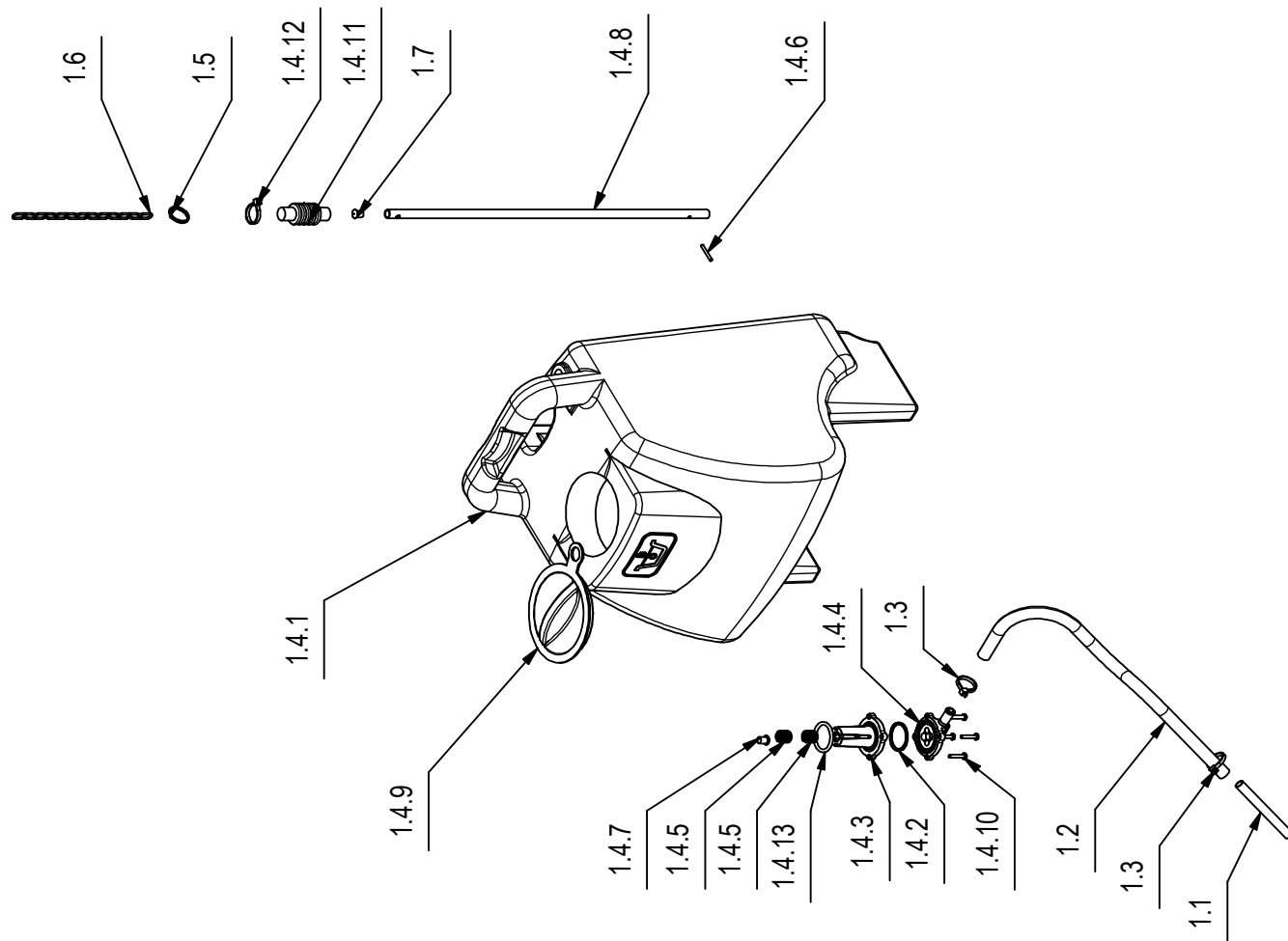

CR-08 GR. SERBATOIO TOR43 (OPZIONALE)
08

POS.	CODICE	QTÀ	DESCRIZIONE	DENOMINATION	DESCRIPTION	BENENNUNG	DESCRIPCION
1	224810	1	GRUPPO SERBATOIO SOFFIAGGIO PER ORBITALE	TANK	RESERVOIR	TANK	TANQUE
1.1	416844	1	TUBO RILSAN 10X8 BIANCO L=0,06MT	PIPE	TUBE	ROHR	TUBO
1.2	411366	1	TUBO D=10 L=620 VITREO	PIPE	TUBE	ROHR	TUBO
1.3	416829	2	FASCETTA PLASTICA 290X4,8 RUFFO	CLAMP	COLLIER	BRIDE	ABRAZADERA
1.4	223621	1	PREM. SERBATOIO SOFFIAGGIO	PRE ASSEMBLY TANK	PRE-ASSEMBLAGE RESERVOIRE	VORMONTAGE TANK	PRE-ENSAMBLAJE TANQUE
1.4.1	437838	1	SERBATOIO MONOSP. SOFFIAGGIO	TANK	RESERVOIR	TANK	TANQUE
1.4.2	408612	1	GUARNIZIONE OR 28,25x2,62	GASKET	JOINT	DICHTUNG	JUNTA
1.4.3	401129	1	GUIDA ASTA RUBINETTO	GUIDE	GUIDE	FÜHRUNG	GUIA
1.4.4	401130	1	RUBINETTO LATO USCITA	COCK	ROBINET	WASSERHAHN	GRIFO
1.4.5	408109	2	MOLLA COMPRESSIONE 13,5X36X1	SPRING	RESSORT	FEDER	RESORTE
1.4.6	409365	1	SPINA ELASTICA INOX 3X24 UNI EN ISO 8752	SPRING PIN	FOURCHETTE	SPANNSTIFT	PASADOR
1.4.7	409849	1	TAPPO VALVOLA	PLUG	BOUCHON	STOPFEN	TAPON
1.4.8	416505	1	ASTA TIRANTE RUBINETTO	ROD	TIGE	STANGE	VARILLA
1.4.9	437839	1	TAPPO PER SERBATOIO SOFFIAGGIO MONOSP.	CAP	CAPUCHON	KAPPE	TAPON
1.4.10	438419	4	VITE AUTOFIL. 3.9X19 PUNTA TRONCA ZINC.	SCREW	VIS	SCHRAUBE	TORNILLO
1.4.11	400200	1	SOFFIETTO PER ASTA SERBATOIO	BELLOWS	SOUFFLET	FALTENBALG	FUELLE
1.4.12	416829	1	FASCETTA PLASTICA 290X4,8 RUFFO	CLAMP	COLLIER	BRIDE	ABRAZADERA
1.4.13	438414	1	ANELLO OR 4112 28,17x3,53	O-RING	JOINT	O-RING	JUNTA ANULAR
1.5	416832	1	ANELLO ASTA TIRANTE RUBINETTO	RING	ANNEAU	RING	ANILLO
1.6	225115	1	CATENELLA 13 ANELLI	CHAIN	CHAINE	KETTE	CADENA
1.7	416822	1	TAPPO KSS HP08	CAP	CAPUCHON	KAPPE	TAPON



HILLYARD INDUSTRIES - PO Box 909 - St. Joseph, Missouri 64502-0909 U.S.A. - Telephone: 816-233-1321 - www.hillyard.com