

ALEX CHAIR ASSEMBLY INSTRUCTIONS



PARTS LIST

Before you begin , please lay out all parts and ensure you have the correct count .

#	DESCRIPTION	QTY	ILLUSTRATION
A	CHAIR BACK	1	
B	CHAIR SEAT	1	
C	FRONT LEGS	2	
1	ALLEN BOLT (5/16" x2")	5	
2	ALLEN BOLT (5/16" x2 1/2")	4	
3	LOCK WASHER (5/16)	9	
4	FLAT WASHER (5/16)	9	
5	Ø4MM ALLEN KEY	1	

ASSEMBLY INSTRUCTIONS

STEP	INSTRUCTIONS	ILLUSTRATION
1	<p>ON A CLEAN, FLAT AREA, PLACE THE CHAIR SEAT (B) UPSIDE DOWN AND REMOVE THE DUST COVER FROM THE UNDERSIDE OF THE CHAIR. ATTACH BOTH FRONT LEGS (C) WITH FOUR 2 1/2" ALLEN BOLTS (2), SPRING WASHERS (3) AND FLAT WASHERS (4). DO NOT TIGHTEN BOLTS COMPLETELY.</p>	

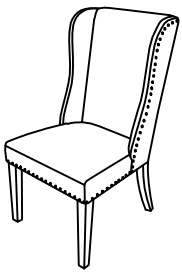

ALEX CHAIR ASSEMBLY INSTRUCTIONS



ASSEMBLY INSTRUCTIONS

STEP

INSTRUCTIONS

ILLUSTRATION

2

CONNECT THE CHAIR BACK (A) TO THE SEAT ASSEMBLY WITH FIVE 2 1/2" ALLEN BOLTS (1), SPRING WASHERS. DO NOT TIGHTEN BOLTS COMPLETELY.

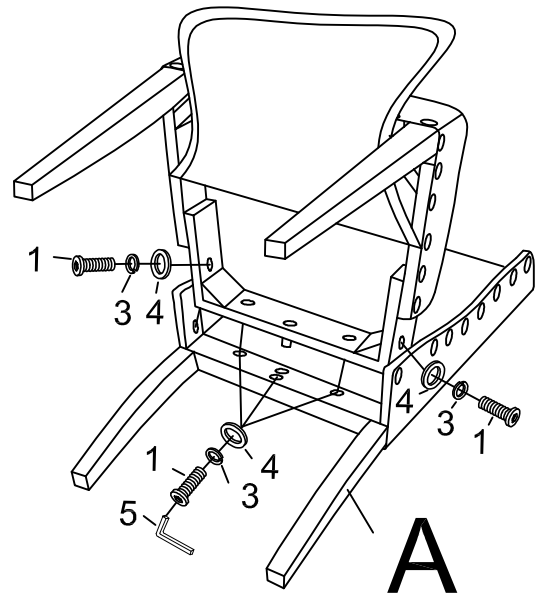

3

PLACE THE LOOSELY ASSEMBLED CHAIR ON A FLAT, LEVEL SURFACE AND PUT PRESSURE ON THE CHAIR SEAT TO LEVEL THE CHAIR. ONCE CHAIR IS LEVEL, TIGHTEN ALL BOLTS FROM PREVIOUS STEPS WITH PROVIDED ALLEN KEY (5) AND THEN REAPPLY DUST COVER TO UNDERSIDE OF SEAT. ENSURE ALL BOLTS ARE COMPLETELY TIGHTENED BEFORE USE.

