

# ECONOMY REACH-IN FREEZER

MODEL:  MXX-23FHC



MXX-23FHC

The Maxx Cold X-Series 23 Cu Ft Single Door Economy Freezer is supplied with 3 heavy-duty adjustable shelves and features a digital solid-state temperature control system with digital display for easy viewing. The energy efficient refrigeration system provides rapid temperature recovery.

## FEATURES AND CONSTRUCTION

- Easy to clean, low maintenance white painted steel exterior and white painted aluminum interior
- Field-reversible hinged door with heavy-duty recessed full-length handle
- Door lock & key set for security
- Three (3) adjustable wire shelves, one (1) fixed half shelf
- Equipped with 2.5" swivel casters
- Digital control system
- LED temperature display
- Automatic defrost system
- Door frame heaters
- Easy to clean/replace removable snap-in gaskets
- Equipped with integrated condensate evaporator therefore no drain line connection is needed
- Front-breathing bottom-mounted condensing unit
- Urethane foam insulated walls

## ELECTRIC

115V / 60Hz / 1Ph  
 (230V / 50-60Hz / 1Ph is available as an option)  
 6' (2m) NEMA 5-15P cord set included

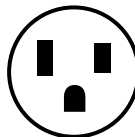

NEMA 5-15P

## 3RD PARTY APPROVALS



Intertek

Certified to ANSI NSF 7



Intertek

Certified to ANSI UL 471



Zero Ozone Depletion Potential



DOE 2018 Compliant

## MAXX COLD WARRANTY (USA / CANADA)

Contact Maxx Cold for warranty statement at  
 TechnicalServices@TheLegacyCompanies.com or 877.368.2797

## NOMINAL STORAGE CAPACITY

MXX-23FHC ..... 23 Cu Ft (651 L)

## TEMPERATURE

Holding temperature ..... -10°F to 10°F (-23°C to -12°C)

- Oversized refrigeration system delivers rapid temperature recovery

MXX-23FHC

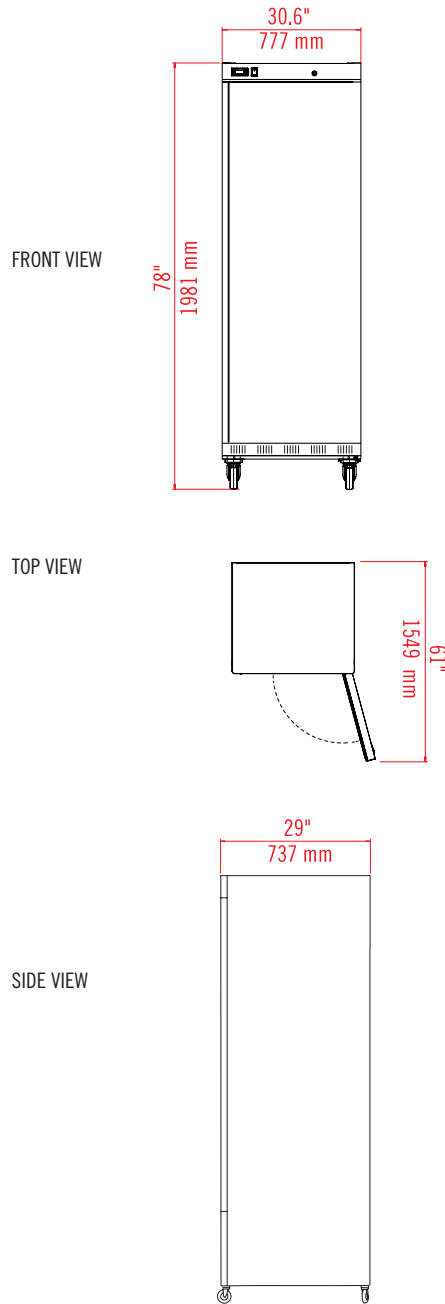

MODEL	EXTERNAL DIMENSIONS	INTERNAL DIMENSIONS	NOMINAL CAPACITY	HOLDING TEMPERATURE RANGE	AMP DRAW	SHIPPING WEIGHT	REFRIGERANT AND CHARGE SIZE	DOORS / SHELVES	ELECTRICAL
MXX-23FHC	30.6" x 29" x 78" (777 x 737 x 1981 mm)	26.3" x 21.6" x 58.9" (668 x 549 x 1496 mm)	23 Cu Ft (651 L)	-10°F to 10°F (-23°C to -12°C)	7.0A	286 lbs (130 kg)	R-290A 4.23oz (120 g)	1 / 3	115V / 60Hz / 1Ph

## INSTALLATION

- Shorter caster options are available to lower the overall height of the unit