

Outdoor Lamp Post with Cross Arm

Bronze

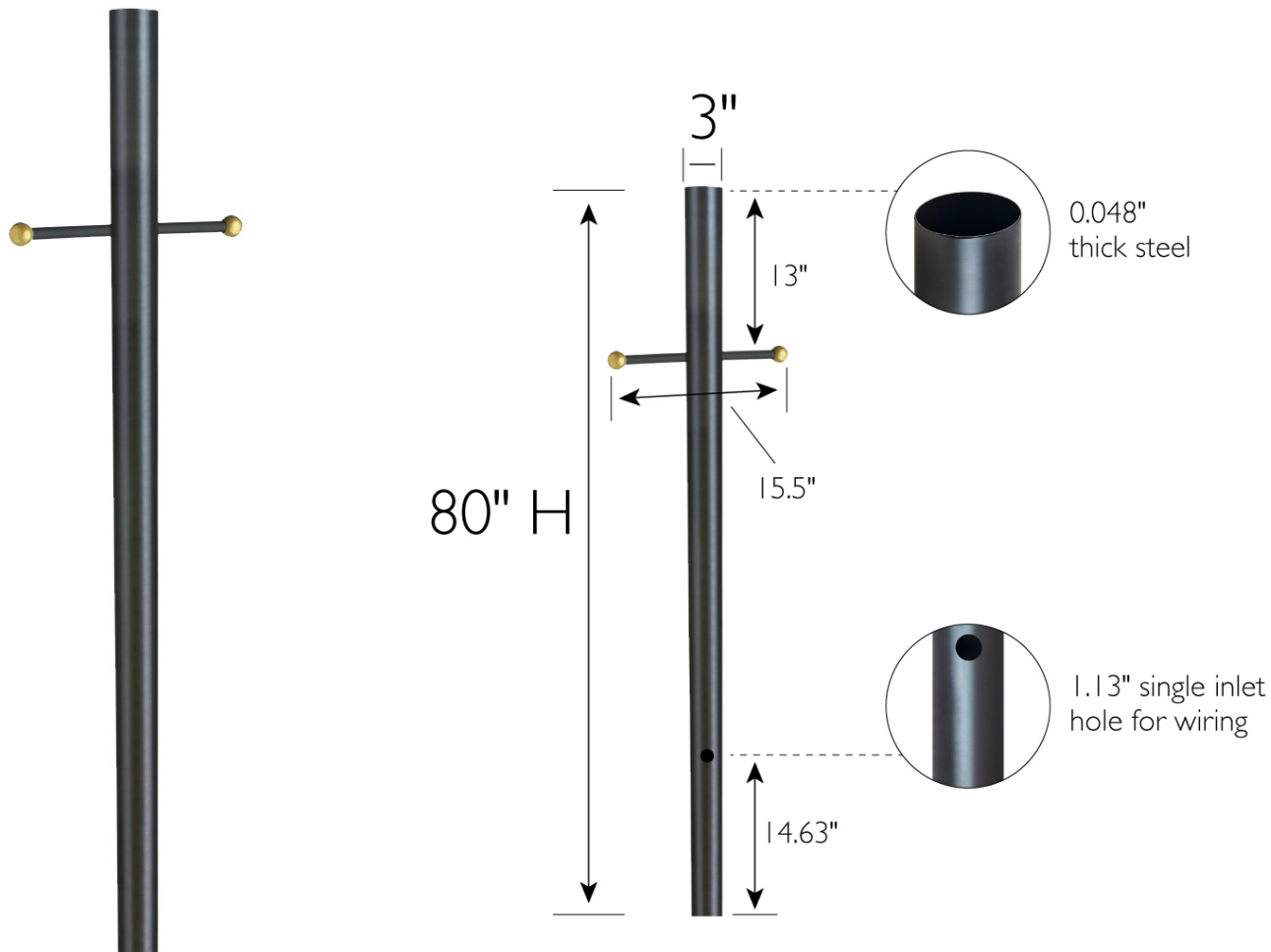

SPECIFICATIONS

MOUNTING:	Direct Burial
MATERIAL CONSTRUCTION:	Steel
ASSEMBLED DIMENSIONS:	80" H x 3" L x 3" D
WEIGHT:	9.72 lbs.

WARRANTY:	10-Year limited warranty
UL/ETL CERTIFICATION:	N/A
WET/DRY/DAMP LISTING:	N/A
ADA COMPLIANT:	N/A
ENERGY STAR CERTIFIED:	N/A



TYPE:
JOB:
ORDER CODE:
APPROVALS: