

Manufactured for:
Dynarex Corporation
10 Glenshaw Street
Orangeburg, NY 10962
USA • www.dynarex.com
Made in China

Reorder No. 12002

Long-Term Care Bed



D200

User Manual

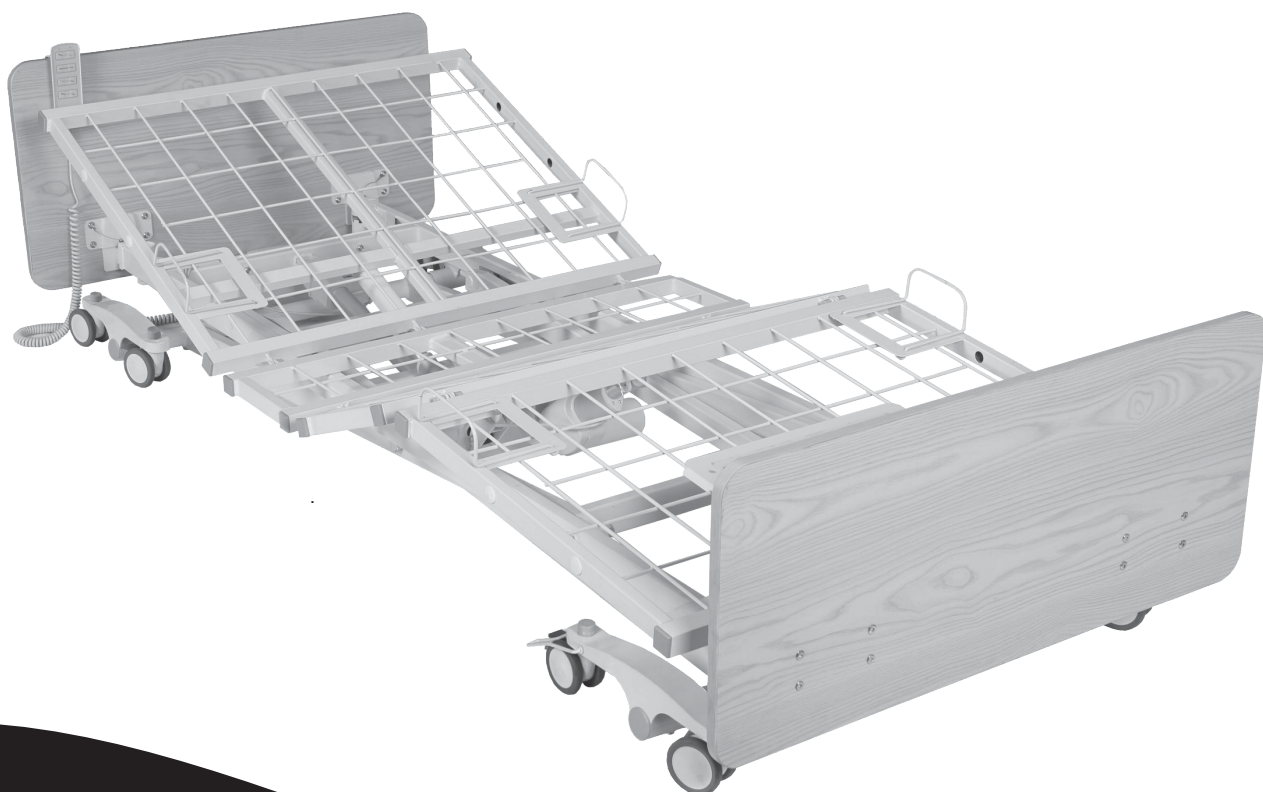

WARNINGS

- Read all instructions before assembling or using the bed.
- **DO NOT** exceed maximum weight limitation of the bed. The maximum safe working load (SWL) of the bed is 450 lb. The suggested patient weight is 400 lb. but varies based on the accessories on the bed.
- The beds are intended for users who fully understand the content of this manual and is not intended for use by children.
- **DO NOT** operate your bed until it is fully assembled and checked. To avoid injury, **DO NOT** attempt to remove the bed from the carton without assistance.
- **DO NOT** use accessories that are not designed or approved for use with the bed. Use only Dynarex approved parts and accessories. **DO NOT** make modifications to the bed without authorization from the manufacturer. Doing so will void the warranty. Serious harm or death may result from the use of improper parts or accessories.
- The bed is **NOT** a transport device. The wheels on the bed are for positioning the bed only.
- Ensure that the casters of the bed are locked at all times to prevent unintended bed movement. The bed should only be unlocked when the bed is moved. If bed is left unlocked unintended movement may occur which may cause damage to the resident or property damage.
- Moving the bed while the caster locks are engaged may damage the bed or the floor. Ensure all the casters are unlocked prior to moving the bed.
- Never permit more than one person on the bed at one time.
- Ensure that the individual is properly positioned. The body weight must be evenly distributed over the sleeping surface. No body part should protrude outside the sleep surface. Caution should be used when transferring the individual to and from the bed.
- **ALWAYS** keep hands and feet away from the bottom of the bed and any moving parts to avoid injury. Due to the low bed clearance, extreme caution should be used as under bed space and/or moving parts can create crush or pinch points.
- **DO NOT** operate the bed with any items under the bed.
- **ONLY** use appropriate mattresses and **ALWAYS** adjust the mattress retainer system accordingly to ensure the mattress is fixed in place. The mattress must fit the frame properly to avoid any entrapment issues. The wrong size mattress may cause serious harm or death. For more information about entrapment, visit <https://www.fda.gov/media/71460/download>.
- Inspect the casters every six months to check for tightness and wear.
- **DO NOT**, under any circumstances, cut or remove the ground prong from any plug. Some devices are equipped with three-prong (ground) plugs for protection against possible shock hazards. Where a two-prong wall receptacle is encountered, it is the personal responsibility and obligation of the customer to contact a qualified electrician to have the two-prong receptacle replaced with a properly grounded three-prong wall receptacle in accordance with the regional and national regulations. If you must use an extension cable, use **ONLY** a three-wire extension cable having the same or higher electrical rating as the device being connected.
- Cables should be routed and secured properly to ensure they are not damaged during normal operation. **DO NOT** use if any cable is cut, frayed or loosely connected to the device. Cables may be damaged by inappropriate handling, e.g. by kinking, shearing or other mechanical damages. The cables are only replaceable by authorized Dynarex service personnel.
- When moving the bed ensure the power cord and pendants are secured. Ensure that the casters do not roll over the cables.
- **DO NOT** attempt to open the pre-sealed actuator or obtain local service, for it will **VOID** the warranty and might result in damage. Consult your dealer or manufacturer for further information.
- This bed is not intended to be used in an oxygen rich environment.
- **DO NOT** allow any part of the bed to become wet or submerged in water.
- **DO NOT** use near fire or explosive gases.
- The hand pendant cord may be a source of entanglement. Patients with decreased mental acuity should not have access to the pendant as serious harm or death may result. An optional staff control embedded into the footboard is available.
- For every 2 minutes of continuous use of the actuator, the bed actuator must not be in use for 18 minutes.

WHEN USING RAILS OR ASSIST BARS:

- Before operating, ensure that the bed rails/bars are assembled and installed correctly as instructed.
- **DO NOT** apply side pressure to the bed rails/bars as it can deform or damage the bed and/or bed rails/bars. Serious harm or death may result from improper use of the bed rails/bars.
- **DO NOT** use the bed rails/bar as a push handle for moving the bed. This could deform or break the bed rails.
- **DO NOT** use the bed rails/bar if proper installation cannot be achieved. Contact your dealer or manufacturer.

DECLARATION – ELECTROMAGNETIC EMISSIONS

Radio Frequency Interference (RFI) influences most electronic equipment. Caution should be exercised regarding the use of portable communications equipment in the area around such equipment. If RFI causes erratic behavior, shut the bed off

immediately. Leave it off while the transmission is in progress.

Interference to electronic equipment may occur in the vicinity of devices marked with this symbol: 

Information about Electromagnetic Emissions

Guidance and Manufacturer's Declaration - Electromagnetic Emissions

The care bed is intended for use in the electromagnetic environment specified below. The customer or user of the care bed should ensure that it is used in such an environment.

Emitted interference	Compliance	Electromagnetic Environment - Guidelines
RF emissions according to CISPR11	Group 1	The care bed uses RF energy only for its internal functioning. Therefore the RF emissions are very low and it is unlikely that nearby electronic devices will be disturbed.
RF emissions according to CISPR11	Class B	The care bed is designed for use in all establishments including domestic establishments and those determined to be directly connected to a public supply network that supplies buildings used for residential purposes.
Emissions of harmonics according to CISPR11	Class A	
Emissions of voltage fluctuations/Flicker according to IEC 61000-3-3	Complies	

Information about Electromagnetic Interference Immunity

Guidance and Manufacturer's Declarations - Electromagnetic Interference Immunity

The care bed is intended for use in the electromagnetic environment specified below. The customer or user of the care bed should ensure that it is used in such an environment.

Interference Immunity Certification	IEC 60601 Test Level	Compliance Level	Electromagnetic Environment - Guidelines
Electrostatic Discharge (ESD) according to IEC 61000-4-2	± 6 kV Contact discharge ± 8 kV Air discharge	± 6 kV Contact discharge ± 8 kV Air discharge	Floors should be wood, concrete or ceramic tile floors. If the floor is covered with synthetic material, the relative humidity should be at least 30%.
Electrical Fast Transients/Bursts according to IEC 61000-4-4	± 2 kV For power lines ± 1 kV for input and output lines	± 2 kV For power lines ± 1 kV For input and output lines	The quality of the supply voltage should be equivalent to that of a typical business or hospital environment.
Surges according to IEC 61000-4-5	± 1 Kv Voltage phase-phase conductor 1 Kv Voltage phase-ground conductor	± 1 Kv Voltage phase-phase conductor 1 Kv Voltage phase-ground conductor	The quality of the supply voltage should be equivalent to that of a typical business or hospital environment.
RF emissions according to CIS-PR11	Class B		The care bed is designed for use in all establishments including domestic establishments and those determined to be directly connected to a public supply.

DECLARATION – ELECTROMAGNETIC EMISSIONS *(Continued)*

Information about Non Life Support Devices Electromagnetic Interference Immunity			
Guidance and Manufacturer's Declarations - Non-Life-Support-Devices Electromagnetic Interference Immunity			
The care bed is intended for use in the electromagnetic environment specified below. The customer or user of the care bed should ensure that it is used in such an environment.			
Interference Immunity Certification	IEC 60601 Test Level	Compliance Level	Electromagnetic Environment - Guidelines
<p>Conducted RF interferences according to IEC 61000-4-6</p> <p>Emitted RF interferences according to IEC 61000-4-3</p>	<p>3 V eff 150 kHz-80 MHz</p> <p>3 V/m 80 MHz-2.5 GHz</p>	<p>3 V eff</p> <p>3 V/m</p>	<p>Portable and mobile radios, including cables, should not be used closer to the care bed than the recommended working clearance that is calculated by the equation for the appropriate frequency.</p> <p>Where P is the Power of the transmitter in Watts (W) according to specifications of the transmitter manufacturer and D is the recommended working clearance in meters.</p> <p>Field strengths from fixed RF transmitters should, at all frequencies, according to a site survey, a-Note p.5 be lower than the level of agreement be b- Note.p.5.</p> <p>In the vicinity of equipment, bearing the following symbol, interference.</p>
<p>Note 1: At 80 and 800 MHz, the higher frequency range must be taken.</p> <p>Note 2: These guidelines may not apply in all situations. The propagation of electromagnetic waves is affected by absorption and reflection from structures, objects and persons.</p>			
<p>a) Field strengths from fixed transmitters, such as base stations of mobile telephones and land mobile radios, amateur radio, AM, FM radio and TV broadcast cannot be predicted with accuracy. To assess the electromagnetic environment due to fixed RF transmitters, an electromagnetic site survey is recommended. If the field strength at the location of the care bed exceeds the specified compliance level above then the care bed should be monitored with respect to its normal operation. If abnormal performance is observed, it may be necessary to take additional measures, such as reorienting or relocating the care bed.</p> <p>b) Over the frequency range 150 kHz to 80 MHz, field strengths should be less than 3 V/m.</p>			

DECLARATION – ELECTROMAGNETIC EMISSIONS *(Continued)*

Working Clearances

Recommended working clearances between portable and mobile RF communications equipment and the care bed

The care bed is intended for use in the electromagnetic environment in which radiated RF disturbances are controlled. The customer or user of the care bed can help to prevent electromagnetic interference by maintaining a minimum distance between portable and mobile RF communications equipment (transmitters) and the care bed as recommended below, according to the maximum output power of the communication device.

Output Power of Transmitter in Watts (W)	Working clearance according to transmission frequency (In meters - M)		
	150 kHz to 80 MHz at 3 V/m	80 MHz to 800 MHz at 3 V/m	800 MHz to 2.5 GHz at 3 V/m
0.01	0.12	0.12	0.23
0.1	0.38	0.38	0.73
1	1.2	1.2	2.3
10	3.8	3.8	7.3
100	12	12	23

For transmitters not rated in the list above, the working clearance can be determined using the equation, which belongs to the transmitter, where P is the nominal output of the transmitter in Watts (W) according to specifications of the transmitter manufacturer.

Note 1: An additional factor of 10/3 is applied when calculating the recommended working clearance between transmitters in the 80 MHz to 2.5 GHz frequency range in order to reduce the probability that a mobile/portable communications device unintentionally brought into the patient area could lead to interference.

Note 2: These guidelines may not apply in all situations. Propagation of electromagnetic waves is affected by absorption and reflection from structures, objects and persons.

TECHNICAL SPECIFICATIONS

OPERATING RANGE	Bed Height	7.8"-30"
	Back Rest Angle	0°-65°
	Knee Break Angle	0°-35°
	Additional Manual Leg Lift	N/A
	Trendelenburg/Reverse Trendelenburg	N/A
	Auto Contour	Yes
WEIGHT LIMIT	Weight Capacity	470 lb.
	Safe Working Load (SWL)	450 lb.
WEIGHTS & DIMENSIONS	Sleeping Surface Dimension (Width × Length – Extension)	36" × 80"-84"-88"
	Caster Size	3"
	Gross Weight	231 lb.
	Net Weight	188 lb.
ELECTRICS	Power Supply (V/PH/Hz)	100-240V/1ph/50-60Hz
	Power Consumption (Max)	230 W
	Number of Motors	3
	Protection Class	IPX4
	Insulation Class	II Type B
	Duty Cycle	Interruption 10%, Max. 2 min./18min.
	Battery backup	Yes, optional
ENVIRONMENT	Operating Temperature	40°F-105°F (5°C-40°C)
	Storage Temperature	15°F-120°F (-10°C-50°C)
	Operation & Storage Humidity	20%-80%
	Operation & Storage Atmospheric Pressure	700-1060 hPa
	Operation & Storage Altitude	≤ 3000 m
	Noise Level	< 50db(a)

ASSEMBLY INSTRUCTIONS

1. UNPACKING THE BED

1. Unpack the components from the shipping cartons.
2. Remove any black zip ties holding the components to the Bed Assembly. White zip ties should not be removed.
3. Upon unpacking your bed, the package should contain all the components shown below.
4. Inspect the bed components for damage. If the bed is damaged, do not use the bed and contact the manufacturer.

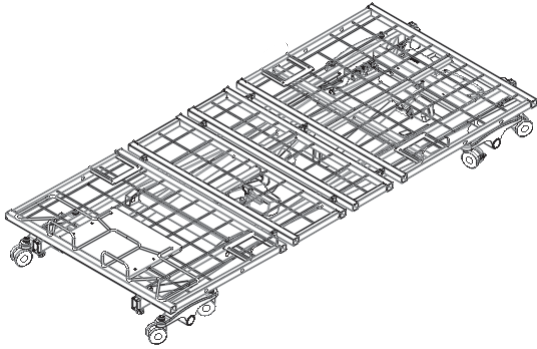

Bed Assembly × 1

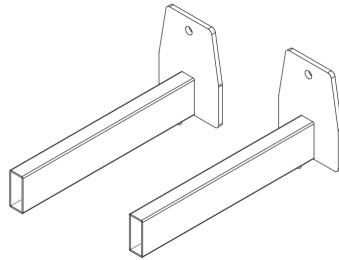

Headboard Bracket × 2

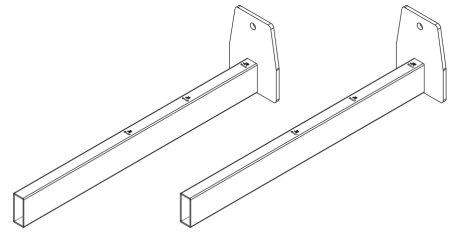

Footboard Bracket × 2

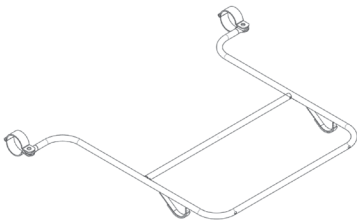

Wall Bumper Bar × 1

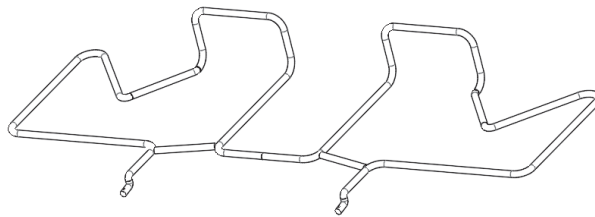

Bed-end Mattress Retainer × 1

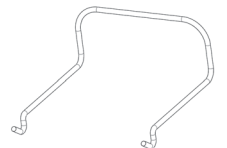

Mattress Retainer × 4



Allen Wrench (size 5 mm) × 1

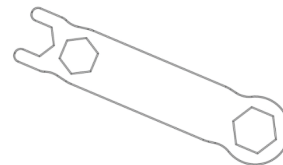

Wrench × 1

ASSEMBLY INSTRUCTIONS *(Continued)*

2.1 ASSEMBLING THE HEADBOARD BRACKETS TO THE BED

1. With the bed raised to its highest position, step on the locking levers to lock the casters on the foot end of the bed.
2. Turn and loosen the black knob on the underside of the bed assembly insertion slots on the head side of the bed.
3. Slide one of the headboard brackets into the slot (the headboard brackets are shorter than the footboard brackets). Tighten the black knob to secure the bracket in place.
4. Repeat the same procedure for the other headboard bracket.
5. Headboard brackets should not be used for length extension. They should always be fully inserted in the slots.

2.2 ASSEMBLING THE FOOTBOARD BRACKETS TO THE BED

1. Turn and loosen the black knob on the underside of the bed assembly insertion slots on the foot side of the bed.
2. Slide one of the footboard brackets into the slot. Tighten the black knob to secure the bracket in place.
3. Repeat the same procedure for the other footboard bracket.

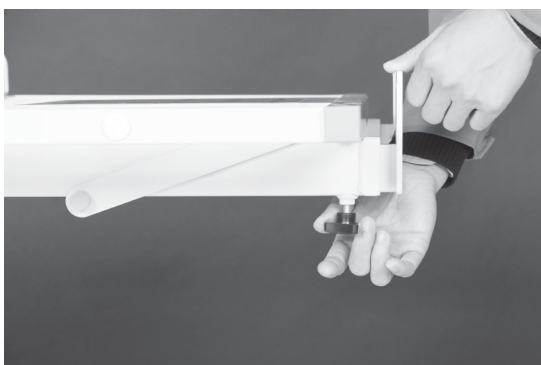
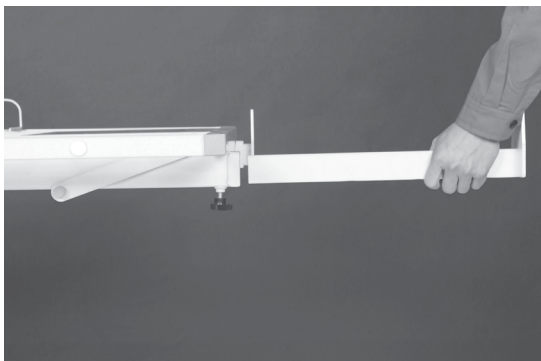

2.3 ASSEMBLING THE HEADBOARDS/ FOOTBOARDS ONTO THE BED

1. With the mounting plates on the headboard facing the bed, slide the mounting plate groove onto the headboard mounting bracket's vertical support.
2. Insert the lock pin through the mounting plate into the headboard to secure the headboard in place. Repeat on the other mounting plate.
3. Repeat the same procedure for the footboard installation.



ASSEMBLY INSTRUCTIONS *(Continued)*

2.4 INSTALLING THE WIDTH MATTRESS RETAINERS

1. Locate the mounting holes for the mattress retainers in the bed deck. Align and insert the mattress retaining wires through the pre-cast holes.
2. Ensure the mattress retainer is flat against the bed deck.
3. Repeat the procedure for all four mattress retainers.

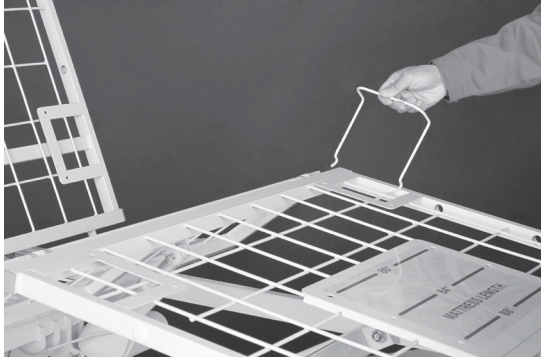

2.5 INSTALLING THE BED-END MATTRESS RETAINER

1. Locate the mounting holes for the bed-end mattress retainer in the foot side of the bed deck.
2. Align and insert the mattress retaining wires through the pre-cast holes.
3. Ensure the mattress retainer is flat against the bed deck.



2.6 INSTALLING THE WALL BUMPER BAR

1. Remove the nuts and bolts from the two round clamps on the caster legs at head of the bed.
2. Align the mounting holes of the bumper bar with those on the clamps.
3. Re-insert the bolts through the clamps and tighten with nuts. Ensure the bumper bar is positioned parallel to the ground.



ASSEMBLY INSTRUCTIONS *(Continued)*

2.7 INSTALLING THE RAILS OR ASSIST BARS

1. Before installing the rails or bars, the bed should be in the flat position.
2. Unclip the metal snap ring and remove the metal pins from the rail mounting brackets.

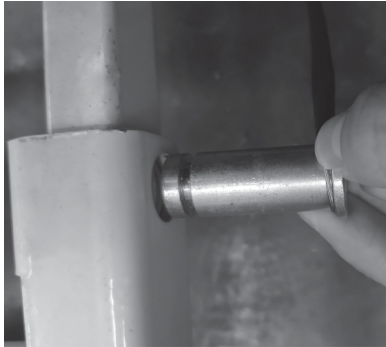

3. Remove cover for the appropriate holes.

Holes for Swing Rails

Holes for Assist Bars

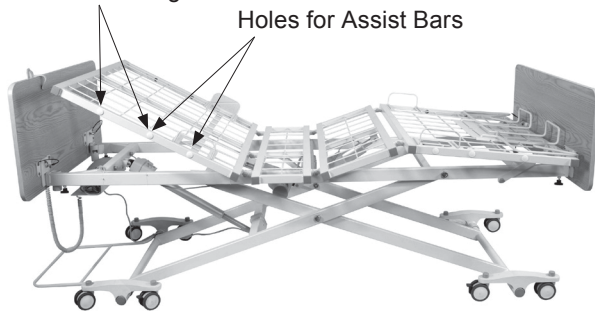

4. Place the rail bracket onto the edge of the bed decking. Align the rail bracket mounting holes with the bed deck mounting holes. Slide the U-shaped insert into the assist bar bracket.

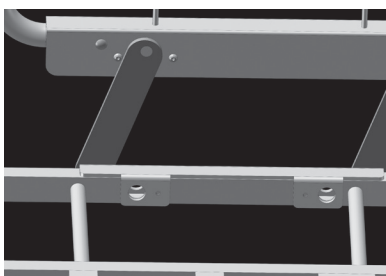
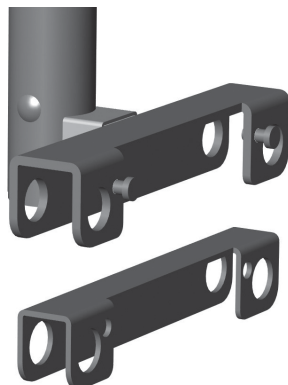

5. Re-insert the metal pins from the outside edge of the bed through the mounting holes and secure with the snap rings on the inside edge of the bed. Make sure the snap rings are positioned in the groove of the metal pins.

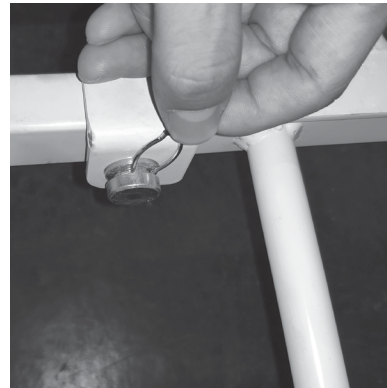

6. If the bed rail or bar has additional Allen screws, tighten the Allen screws next to the metal pins.

7. Repeat the same procedure to install the other rail.

2.8 CONTROL BOX CONNECTIONS

Upon opening the control box, each motor connection port is numbered for ease of identification.



1 2 3 4 5 6

1. Battery Backup Port
2. Backrest Motor
3. Knee-break Motor
4. Bed Lift Motor
5. Spare
6. Port for hand pendant or staff control

ASSEMBLY INSTRUCTIONS *(Continued)*

2.9 INSTALLING THE FOOTBOARD WITH STAFF CONTROL

1. Unplug the bed from the outlet prior to installation.
2. Mount the footboard with built-in staff control.



3. Open the locking lid of the control box to expose the port connections.

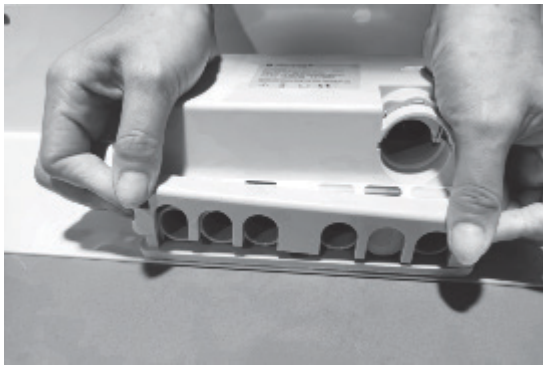

4. Disconnect the hand pendant connection to the control box and replace it with a cable splitter.



5. Lift up the lid on one of the splitter ports and plug in the hand pendant. Push down the lid to secure the connections.



6. Repeat the procedure and plug the cord from the staff control footboard into the other splitter port. Use the included zip ties to secure the cord to the bed frame. Ensure the cord does not interfere with the bed operation.



7. Reinstall the control box locking lid. There should be an audible click.
8. Plug the bed into an appropriate outlet and test functions to ensure all functions work correctly.

ASSEMBLY INSTRUCTIONS *(Continued)*

2.10 INSTALLING THE BATTERY BACKUP

1. Unplug the bed when installing the backup battery.
2. Affix the battery backup with nuts and bolts to the side of the control box, on the same holding plate.

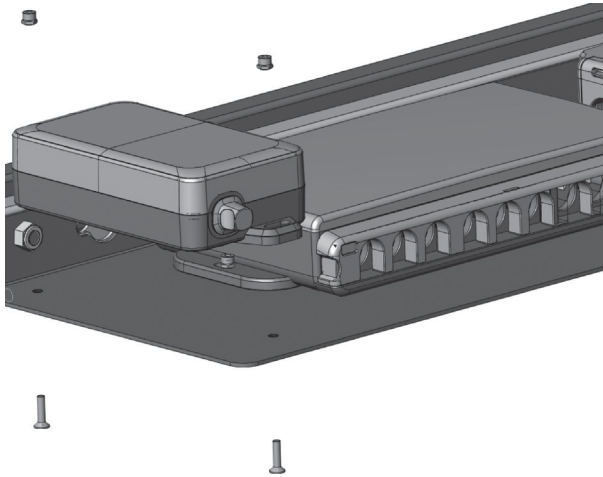

3. Open the control box locking lid by pressing in the sides and lift it up, to expose the connection parts.



4. Connect the back up battery cord to the control box. The connection port is indicated with a battery symbol above.
5. Close the locking lid, there should be an audible click, switch the power supply back on.

ASSEMBLY INSTRUCTIONS *(Continued)*

2.11 INSTALLING THE COMPOSITE HEAD & FOOTBOARDS

1. Raise the bed to its highest position and lock the bed in place.
2. Turn and loosen the two black turn knobs on the underside of the Bed Assembly insertion slots.
3. Slide the footboard frame into the slots (the footboard frame is longer than the headboard frame). The plastic levers mounted on the footboard frame should be on top. Tighten the black turn knobs.

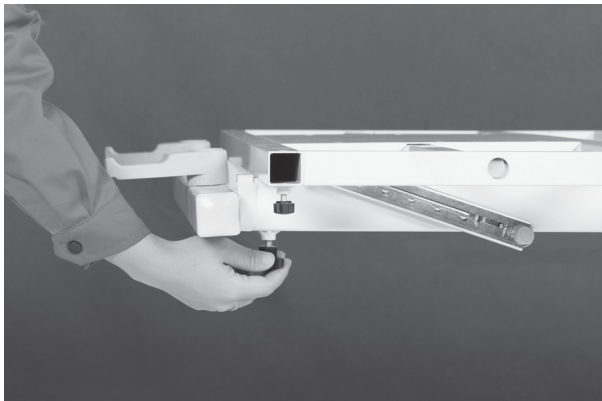
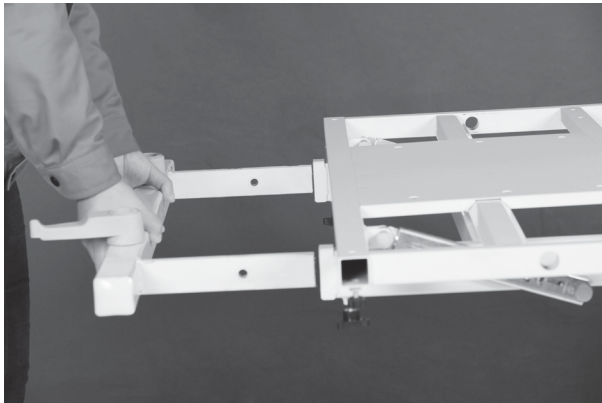

4. Ensure the two plastic levers on the footboard frame point away from the bed.
5. Insert the footboard squarely through the plastic levers into the footboard frame.



6. Rotate the plastic levers until they are paralleled with the footboard, pointing to the sides of the bed. This will lock the footboard in place.

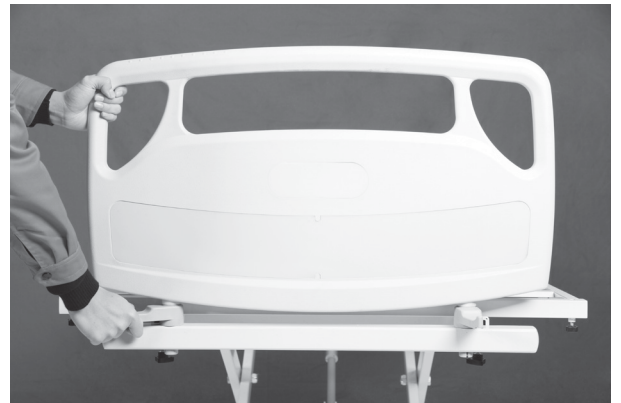

7. Repeat the same procedure for the headboard installation.

EQUIPMENT OPERATION

1. POSITIONING THE BED

To position the bed, unlock the casters. Once the bed is in its desired location, lock all the casters by pushing on the locking levers.

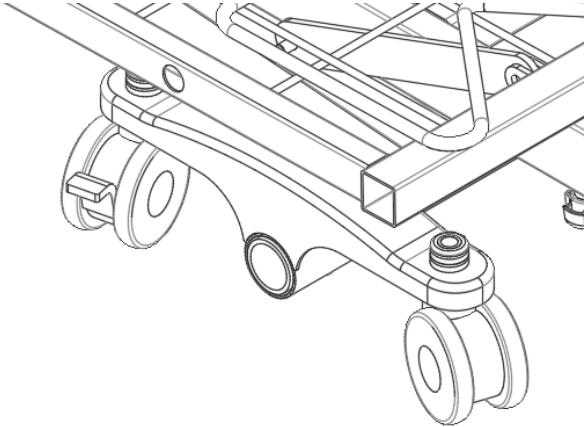

2. EXTENDING THE LENGTH OF THE BED FROM 80" TO 84" OR 88"

1. Loosen the two black knobs located on the underside of the bed frame securing the footboard frame. (Refer to Section 2.3 on page 8.)
2. Pull the footboard frame away from the bed squarely with both hands to the required length. The distances are marked on the footboard frame, 80", 84" and 88". Tighten the securing knobs once desired length is set.
3. Adjust the bed end mattress retention frame to the required position. The extension lengths are marked on the bed platform.

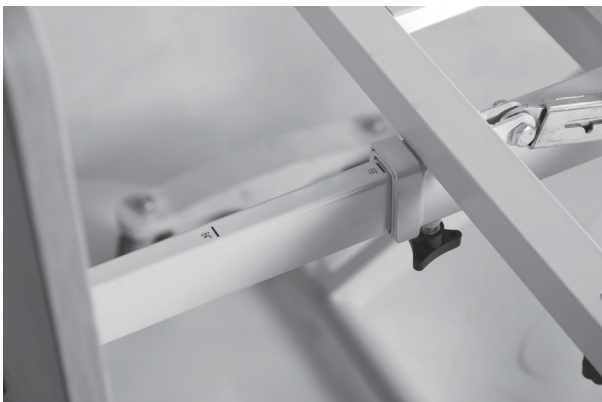

3. USING THE HAND PENDANT

The UP arrow (Δ) indicates raising the corresponding parts of the bed.

The DOWN arrow (∇) indicates lowering the corresponding parts of the bed.



1. Use button 1 & 2 to adjust the backrest up or down.
2. Use button 3 & 4 to adjust the knee break up or down.
3. Use button 5 & 6 to adjust the backrest and knee break up or down simultaneously (Auto Contour feature)
4. Use button 7 & 8 to raise or lower the bed platform.

EQUIPMENT OPERATION *(Continued)*

4. OPERATING THE BED RAILS

METAL SWING RAIL (REORDER NUMBER 12950)

Raise Bed Rail: Pull the bed rail upwards until the rail is securely locked in place.

Lower Bed Rail: Squeeze the release lever at the bottom corner of the bed rail and slowly lower the bed rail to its lowest position.

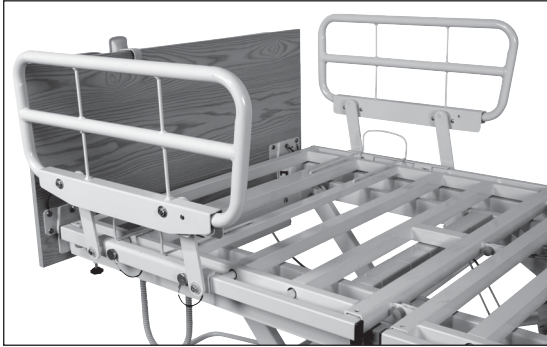

COMPOSITE SWING RAIL (REORDER NUMBER 12951)

Raise Bed Rail: Pull the bed rail upwards until the rail is securely locked in place.

Lower Bed Rail: Press the release button and slowly lower the bed rail to its lowest position.



ROTATING ASSIST BAR (REORDER NUMBER 12952)

Parallel Assist Bar Alignment: Lift up and rotate the bar until it is parallel to the bed edge. Lower the bar and ensure it is securely locked in place.

Perpendicular Assist Bar Alignment: Lift up and rotate the bar until it is perpendicular to the bed edge. Lower the bar and ensure it is securely locked in place.

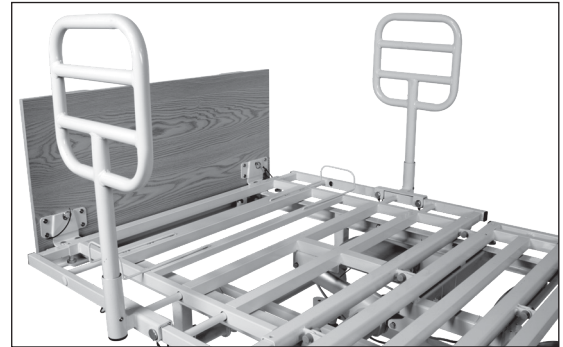

PIVOT ASSIST BAR (REORDER NUMBER 12953)

Raise Assist Bar: Pull the bar upwards until the bar is securely locked in place. Ensure the release button is engaged.

Lower Assist Bar: Pull the release knob and slowly lower the bar to its lowest position.

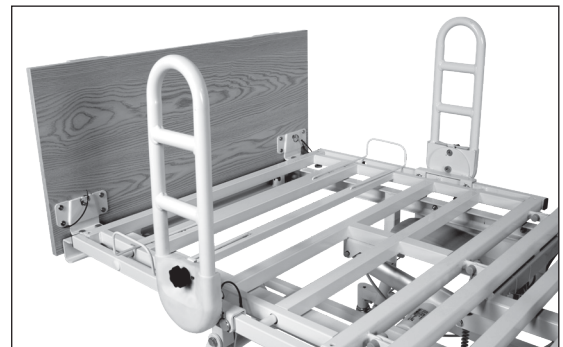

TROUBLESHOOTING GUIDE

SYMPTOMS	POSSIBLE FAULTS	POSSIBLE SOLUTIONS
<p>Bed idle when hand pendant buttons are pressed.</p>	<p>Adjustment may be at the maximum or minimum position.</p> <p>Power cord not connected or damaged.</p> <p>Hand pendant or actuator connectors are loose.</p> <p>Load is too heavy.</p>	<p>Check if other buttons are working.</p> <p>Ensure the power cable is properly connected to the electrical socket and the bed.</p> <p>Ensure tight connection of all connectors to control box.</p> <p>Ensure the load weight is within the designated capacity. Reduce the load.</p>
<p>Adjustment via hand pendant or Staff Control only partially occurs and stops.</p>	<p>The bed may be overloaded.</p> <p>The bed may be constrained from moving.</p> <p>Actuators connection may be loose or damaged.</p> <p>Thermal shut down may have occurred.</p> <p>If battery backup is installed, the battery may be low.</p>	<p>Ensure the load weight is within the designated capacity. Reduce the load.</p> <p>Check for obstructions.</p> <p>Ensure actuator is properly secured to the bed.</p> <p>Wait at least 20 minutes before trying the functions again. The bed is intended to be used for 2 min every 20 min.</p> <p>Plug bed into appropriate power source.</p>
<p>Bed not responding to hand pendant or Staff Control.</p>	<p>The lockout function may be engaged.</p> <p>Cables may be loose.</p> <p>Thermal shut down may have occurred.</p>	<p>Ensure that the lockout function is not engaged on the Staff Control.</p> <p>Ensure all cables are fully inserted.</p> <p>Ensure the bed is plugged into appropriate outlet.</p> <p>Unplug bed for 60 seconds and plug back in.</p> <p>Wait at least 20 minutes before trying the functions again. The bed is intended to be used for 2 min every 20 min.</p>

TROUBLESHOOTING GUIDE *(Continued)*

Casters/Brakes noisy or stiff.	Debris or fluff in bearings.	Clean or replace casters.
Noisy or dry sound from pivot points.	Needs lubrication.	Lubricate your bed.
Unusual noise from actuator.	Actuator is worn, damaged or spindle is bent.	Replace the actuator. Contact your supplier.
Head/Footboard unstable.	Head/Footboard frames are not tightly secured.	Refer to Assembly Instructions.

LIMITED WARRANTY

Your Dynarex Product is warranted to be free of defects in materials and workmanship for Fifteen (15) years on structural Steel, Three (3) years on electrical and mechanical, and One (1) year on all other parts and components from the original date of purchase. This item was built to exacting standards and carefully inspected prior to shipment. This warranty is an expression of our confidence in the materials and workmanship of our products and our assurance to the consumer of years of dependable service.

The Warranty shall not apply under the following conditions:

- Problems arising from normal wear
- Problems arising from failure to adhere to the product instructions
- Problems arising from misuse, negligence, accident or improper operation, maintenance or storage
- Problems arising from modifications or unauthorized repairs, parts or attachments

- Products where the serial number has been removed or defaced
- Problems with non-durable components, such as rubber accessories, casters, and grips, which are subject to normal wear and need periodic replacement

Dynarex shall not be liable for any consequential or incidental damages whatsoever. Dynarex shall repair or replace defective products at its option. The foregoing warranty is exclusive and in lieu of other express warranties, if any, including the implied warranties of merchantability and fitness of a particular purpose. The remedy for any violation of the implied warranty shall be limited to repair or replacement of the defective product pursuant to the terms contained herein.

If you have a question about your Dynarex device or this warranty, please contact an authorized Dynarex dealer.



SYMBOL GLOSSARY
For an explanation of symbols used in Dynarex packaging, visit dynarex.com/symbols.php

WARNING:
Cancer and Reproductive Harm
www.P65Warnings.ca.gov

R220329

SERVICE RECORD

DATE	PERFORMED BY	CONDITION REPORT

SERVICE RECORD

DATE	PERFORMED BY	CONDITION REPORT