

DWG. NO. 352-900-1160H		
REV	DESCRIPTION	BY DATE APPD
F	ECR 7395	6/11/98 PRP

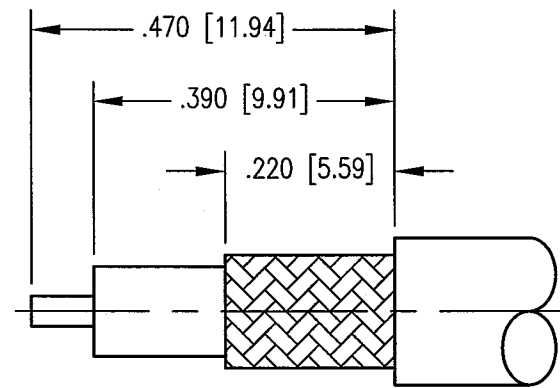
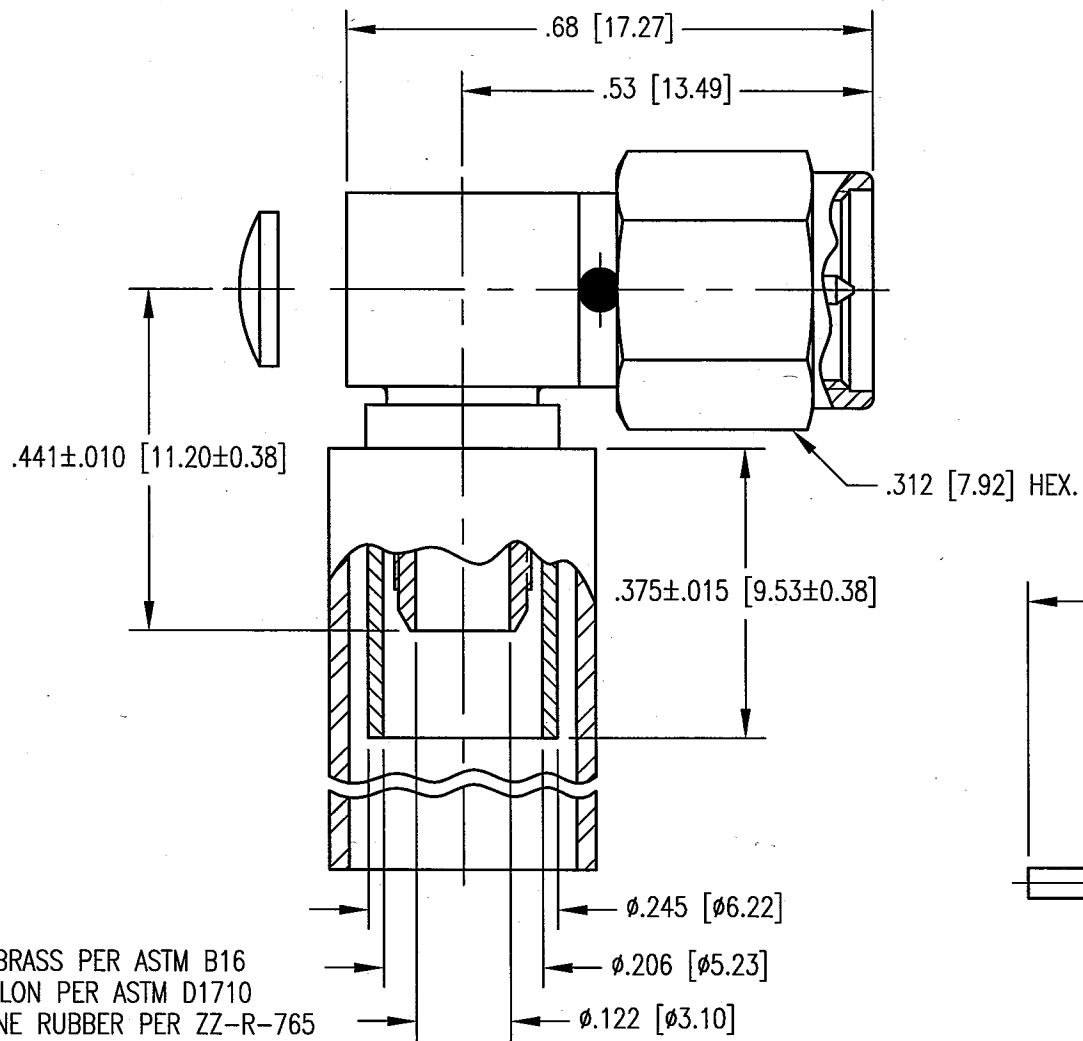

CABLE TRIMMING DIMENSIONS

NOTES:

- MATERIALS:  
 METAL PARTS: BRASS PER ASTM B16  
 INSULATOR: TEFLON PER ASTM D1710  
 GASKET: SILICONE RUBBER PER ZZ-R-765  
 HEAT SHRINK TUBING: POLYOLEFIN-FLEXIBLE  
 RETAINING RING: BERYLLIUM COPPER PER ASTM B194
- FINISH:  
 CONTACT: .000030 MIN. GOLD PER MIL-G-45204 OVER  
 .000050 MIN. NICKEL PER QQ-N-290  
 FERRULE AND CAP: .000005 MIN. GOLD PER MIL-G-45204  
 OVER .000050 MIN. NICKEL PER QQ-N-290  
 ALL OTHER METAL PARTS: .000015 MIN. GOLD PER MIL-G-45204  
 OVER .000050 MIN. NICKEL PER QQ-N-290
- FOR USE WITH RG-58 CABLE OR EQUIVALENT.
- FOR CABLING PROCEDURE USE CAP 9-05 WITH TRIMMING DIMENSIONS SHOWN.
- CRIMP FERRULE USING .213 HEX DIE.

PER ASME Y14.5M-1994 UNLESS OTHERWISE SPECIFIED: DIMENSIONS ARE IN INCHES [MM]		<b>NORTHROP GRUMMAN</b>	
TOLERANCES: DECIMALS .xxx ± .01 [0.254] .000 ± .005 [0.127] ANGLES ± 2°		Winchester Electronics 400 Park Road Watertown, CT 06795	
SCALE: 4:1		TITLE SMA RIGHT ANGLE PLUG	
CUSTOMER DRAWING			
DRAWN KJT	DATE 3/11/98	CHECKED JMC	DATE 3/11/98
APPROVED PRP	DATE 3/11/98	APPROVED PRP	DATE 3/11/98
A		352-900-1160H	SHT. OF REV. 1 1 F