

# JACK & JUNE

## HEXAGONAL SAND BOX

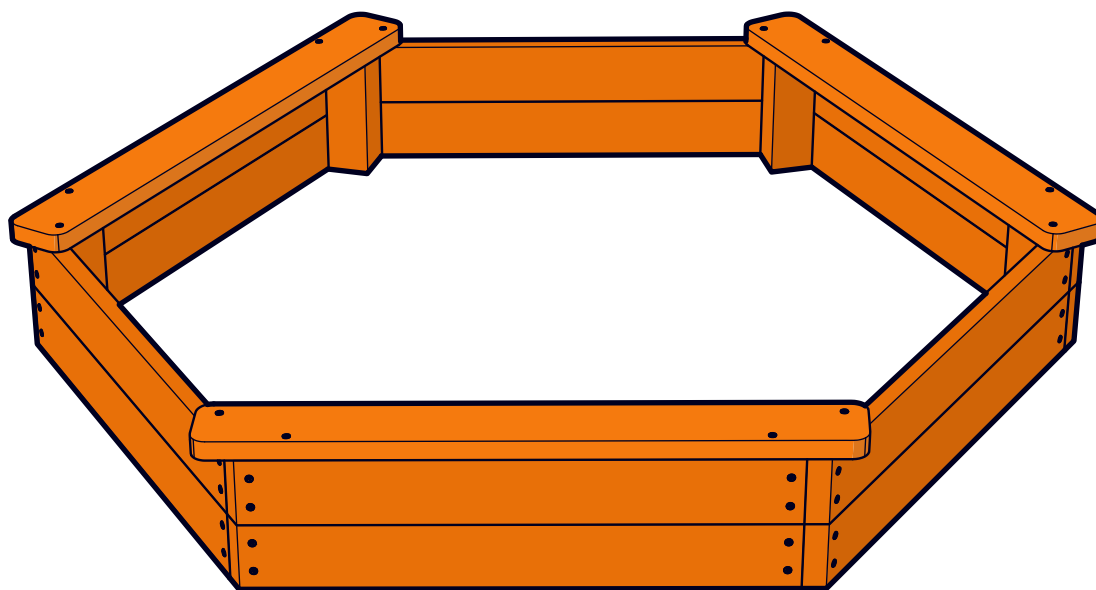

### ASSEMBLY INSTRUCTIONS

for children 18+ Months

**Assembly requires 1 adult  
(approx. 30 minutes assembly time)**

FOR FAMILY OUTDOOR DOMESTIC USE ONLY

Warning: not suitable for children under  
36 months until fully assembled due to small parts

**PG503W**

## Advisory Section

To ensure the safety of you, the installer and your children, it is important that these instructions are read fully before commencing the positioning and assembly of this product. Assemble sandbox on a clean flat area.

### Keep your sandbox safe for the children

1. Always cover the sandbox when not in use, to prevent unwanted animals from playing in the sand.
2. Before covering your sandbox, place a large object in the center of the sand to prop up the cover.  
This will allow water to drain off the cover, and prevent any rain water from "pooling" in the center of the sand box.  
This must be checked regularly.
3. Should any water still accumulate and form a pool, please ensure that this water is removed. Standing water can pose a danger to children.
4. Regularly check sand for impurities and any other sharp objects that may cause harm to children.
5. Use washed playsand suitable for use in children's sand boxes.

## Timber Advice

This product has been made from premium timber. Great care has been taken in selecting, and machining the timber before it is presented to you. Timber is a natural product and as such may experience changes throughout the course of its life. This means it may:

- Develop openings (gaps, slits, apertures, cracks, splits) along the line of the grain. These openings are due to the difference in moisture content between the internal and outer surfaces of the timber. This is to be expected, is totally acceptable and will not affect the integral strength, life or guarantee of the product.
- Warp and distort its shape. Any distortion will be slight and will not affect the safety or enjoyment of this product.
- Fade as the timber reacts with sunlight. The timber should be treated with a proprietary product to act as a protective barrier, i.e. a water repellent, upon completion of assembly and on an annual basis.
- After first year of service treat product with a good quality treatment safe for children's use.

## Routine Maintenance

It is advised that on a regular basis (i.e. at the beginning of the season and monthly thereafter) all main parts are checked as secure have no sharp points/edges and are intact. Replace, and/or tighten when necessary. Failure to do so may result in an injury or hazard.

Remember to keep these instructions in a safe place for future reference.

# STANDARD PARTS LIST

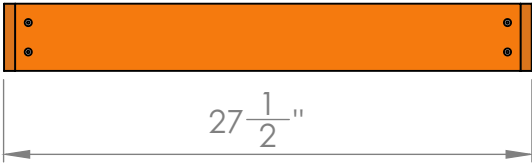

C1075  
QTY. 12

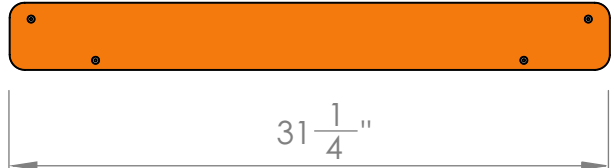

C1077-2  
QTY. 3

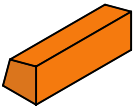

C1076  
QTY. 6

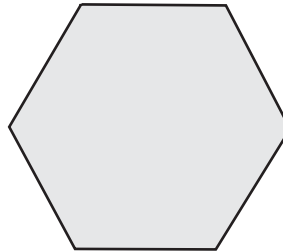

D1090  
Tarp for Sand  
QTY. 1

# HARDWARE



#8 X 1.625 PHILLIPS FLAT  
HEAD WOOD SCREW  
QTY. 60

# TOOLS NEEDED



PHILLIPS SCREW DRIVER

**NOTE:**

An electric screwdriver is helpful in assembly. However, please set at low torque and use extreme caution with an electric screwdriver because you could over-tighten the hardware & strip out the screws.

**HARDWARE NEEDED (ACTUAL SIZE)**



#8 X 1.625 WOOD SCREW  
QTY. 12

**STEP 1**

Attach **C1075** board to **C1076** post as shown.

Repeat until **6** assemblies are built.

**NOTE:** Tighten, but DO NOT strip out the screws.

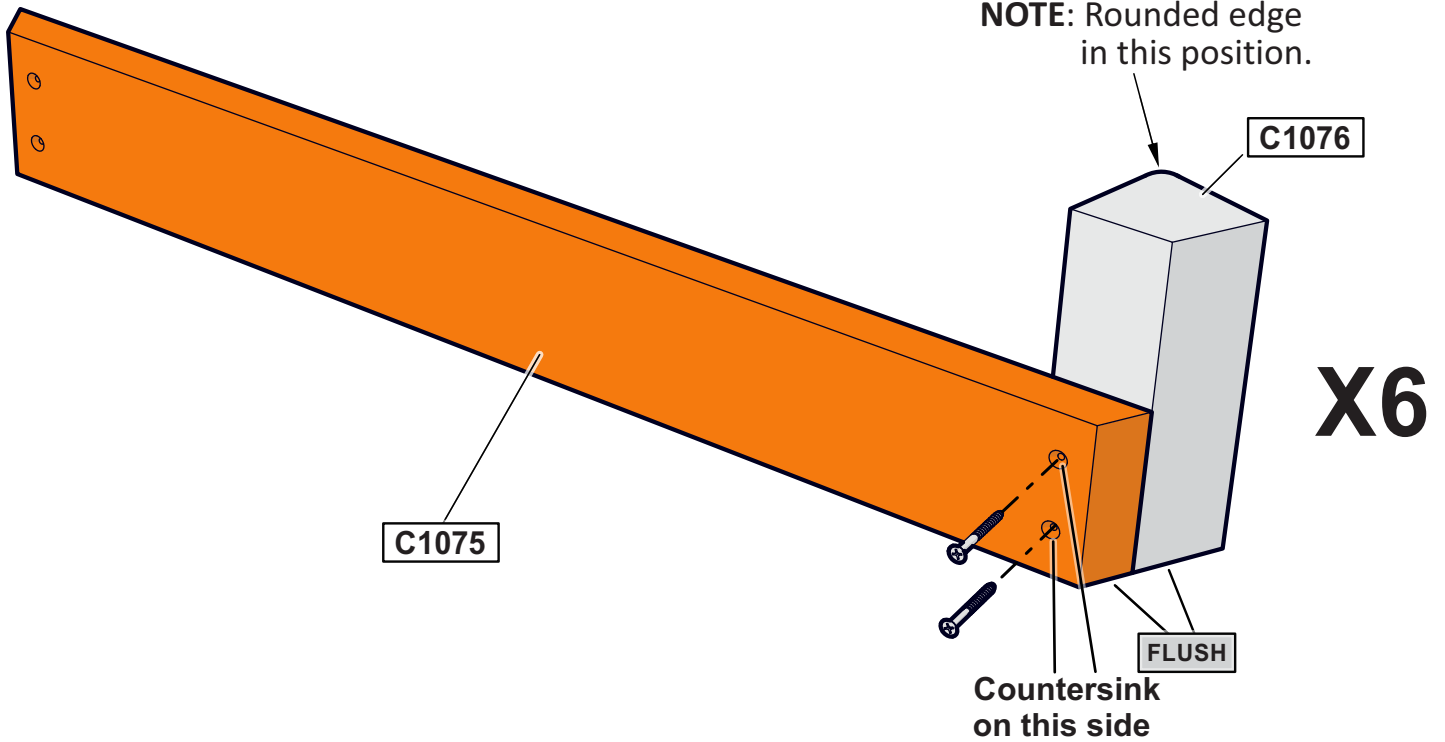

**TOP VIEW 1**

**NOTE:** Rounded edge  
in this position.

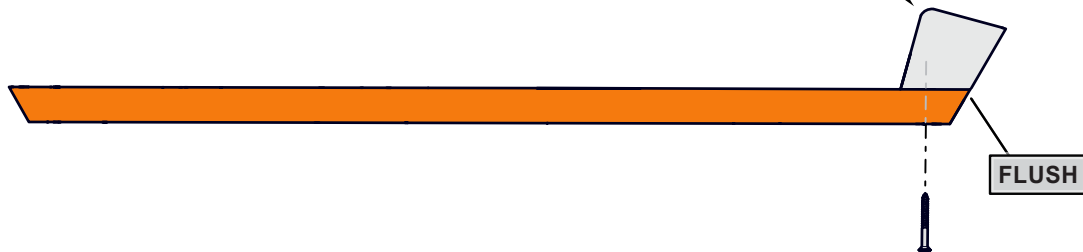

## HARDWARE NEEDED (ACTUAL SIZE)



#8 X 1.625 WOOD SCREW  
QTY. 2

## STEP 2

On a clean flat surface attach a **Step 1** assembly to a second **Step 1** assembly as shown. Repeat until **Step 6**.

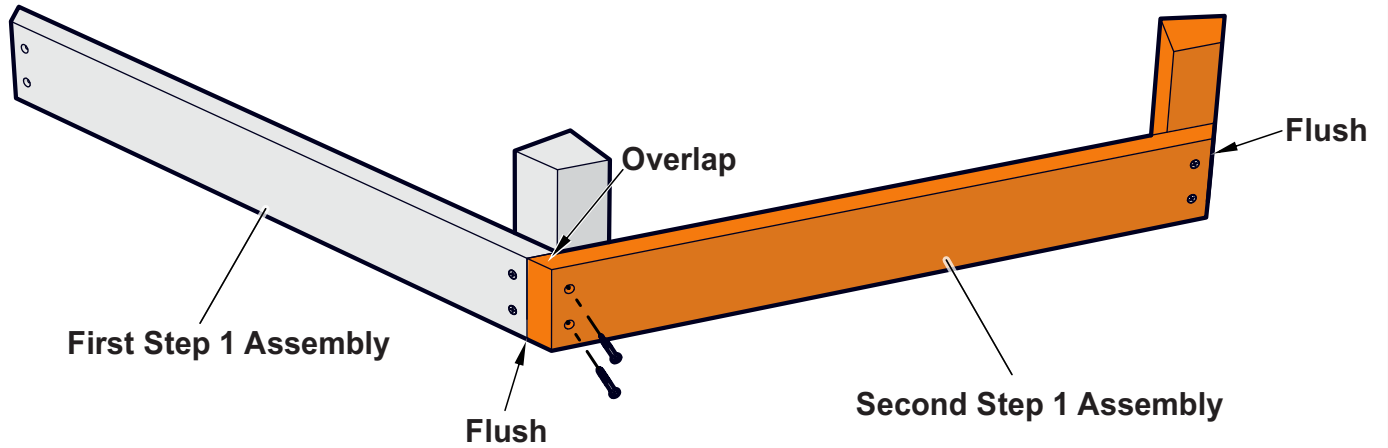

Please note overlap & Flush Fit.

## TOP VIEW 2

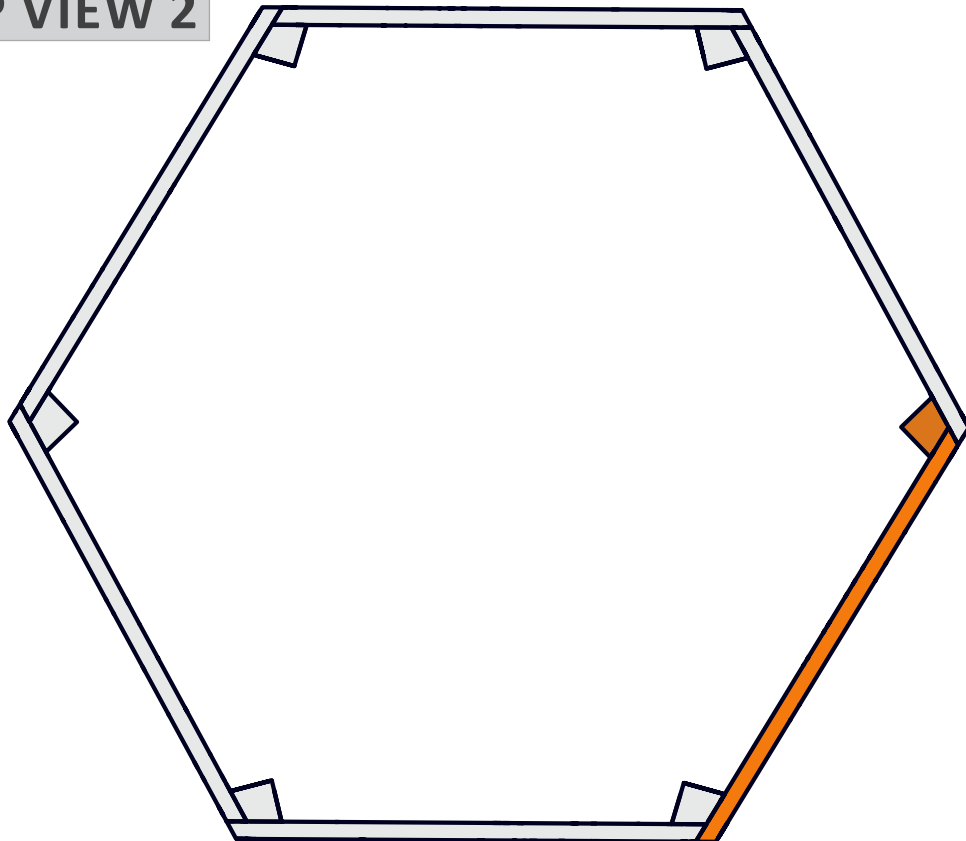

**STEP 3**

**HARDWARE NEEDED (ACTUAL SIZE)**



#8 X 1.625 WOOD SCREW  
QTY. 2

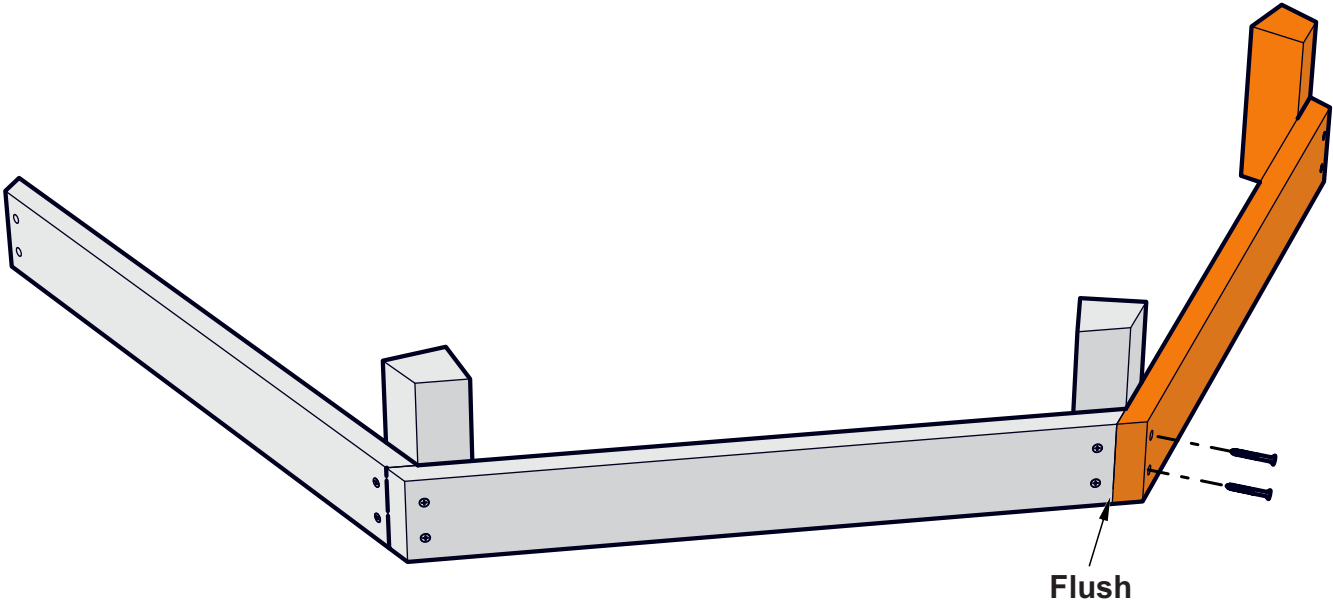

**STEP 4**

**HARDWARE NEEDED (ACTUAL SIZE)**



#8 X 1.625 WOOD SCREW  
QTY. 2

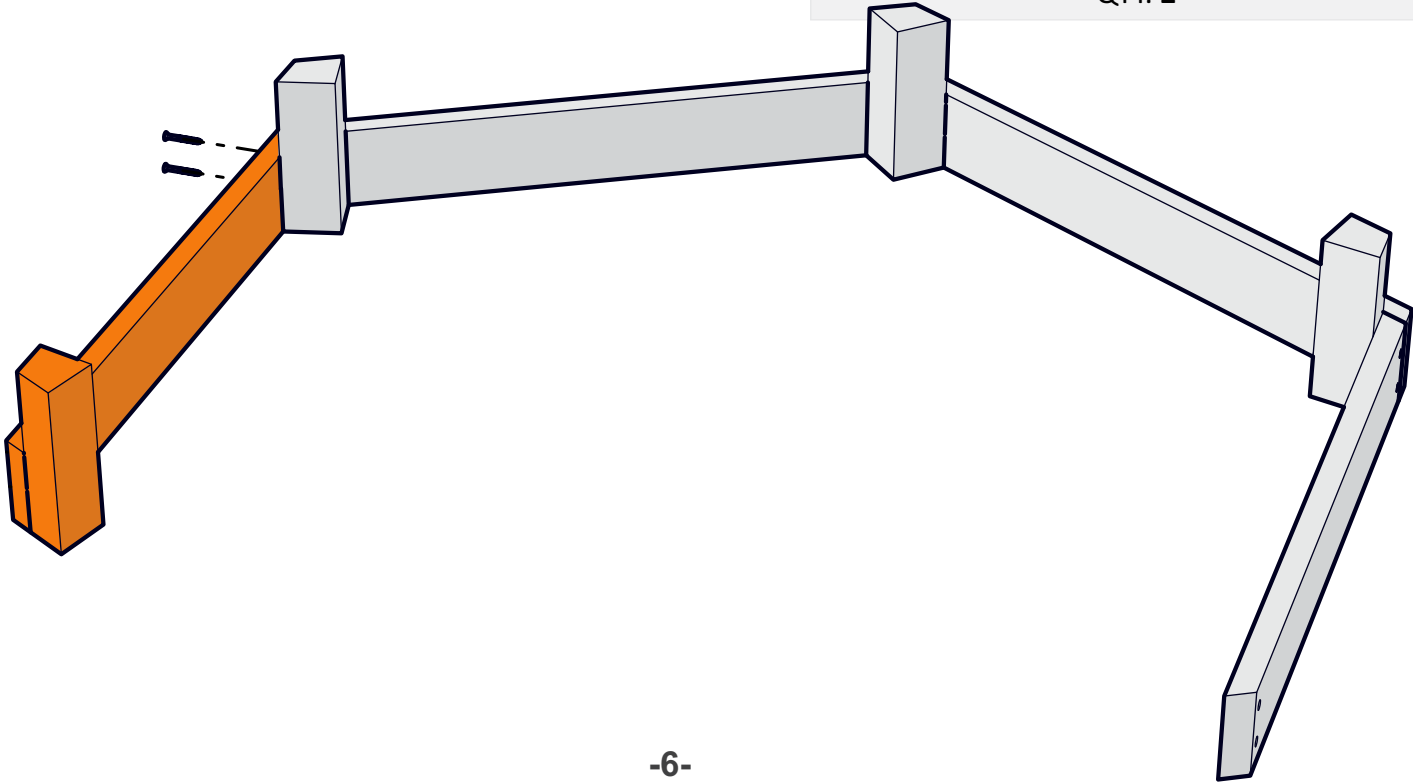

## STEP 5

### HARDWARE NEEDED (ACTUAL SIZE)



#8 X 1.625 WOOD SCREW  
QTY. 2

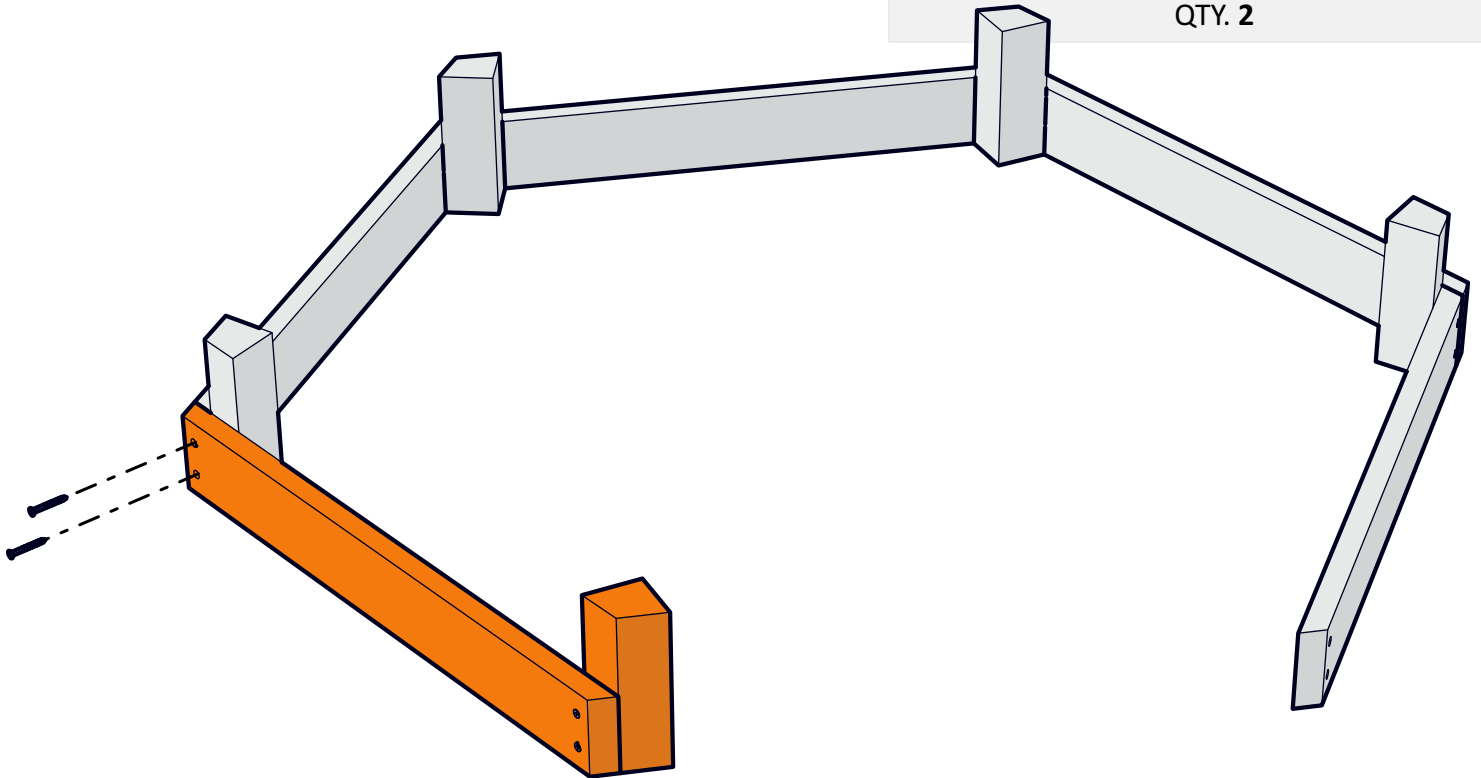

## STEP 6

### HARDWARE NEEDED (ACTUAL SIZE)



#8 X 1.625 WOOD SCREW  
QTY. 4

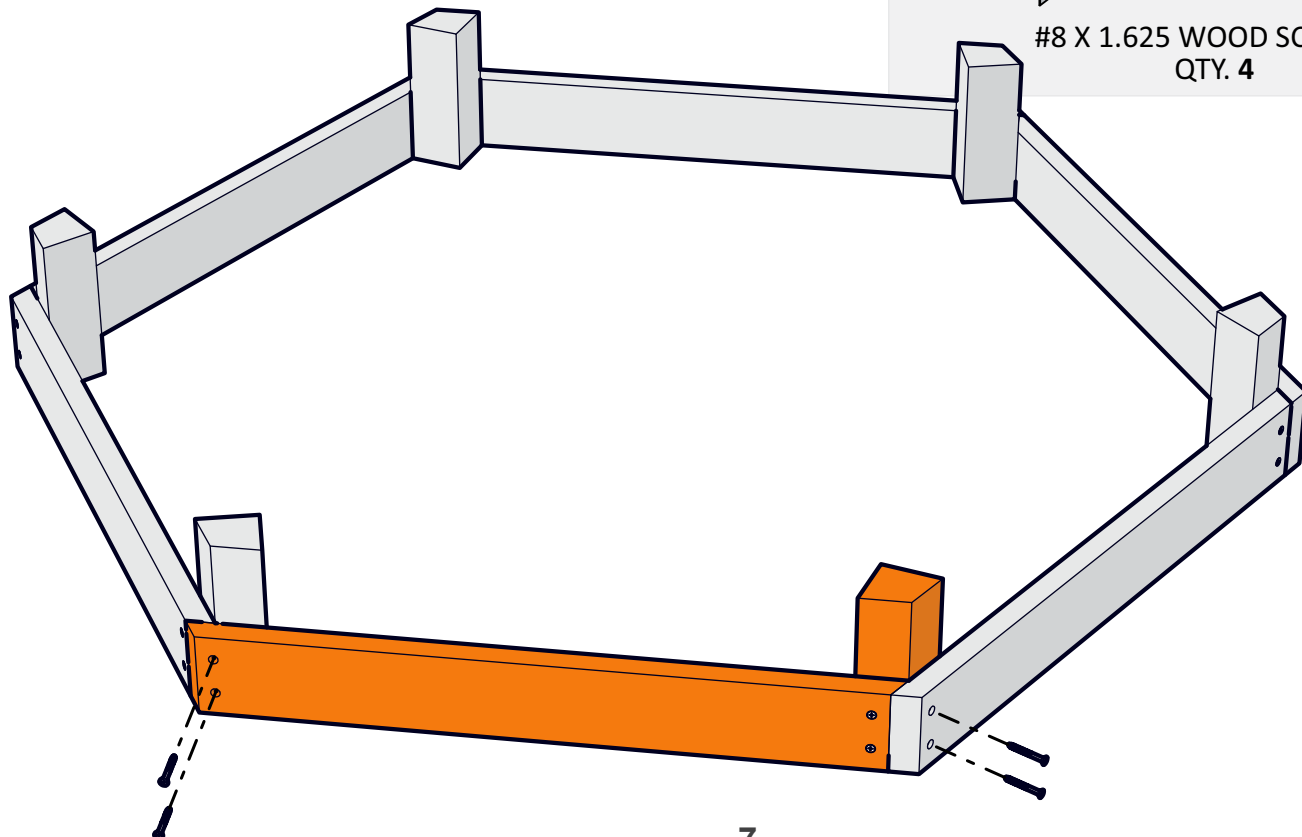

**HARDWARE NEEDED (ACTUAL SIZE)**



#8 X 1.625 WOOD SCREW  
QTY. 4

**STEP 7**

Attach **C1075** board as shown.

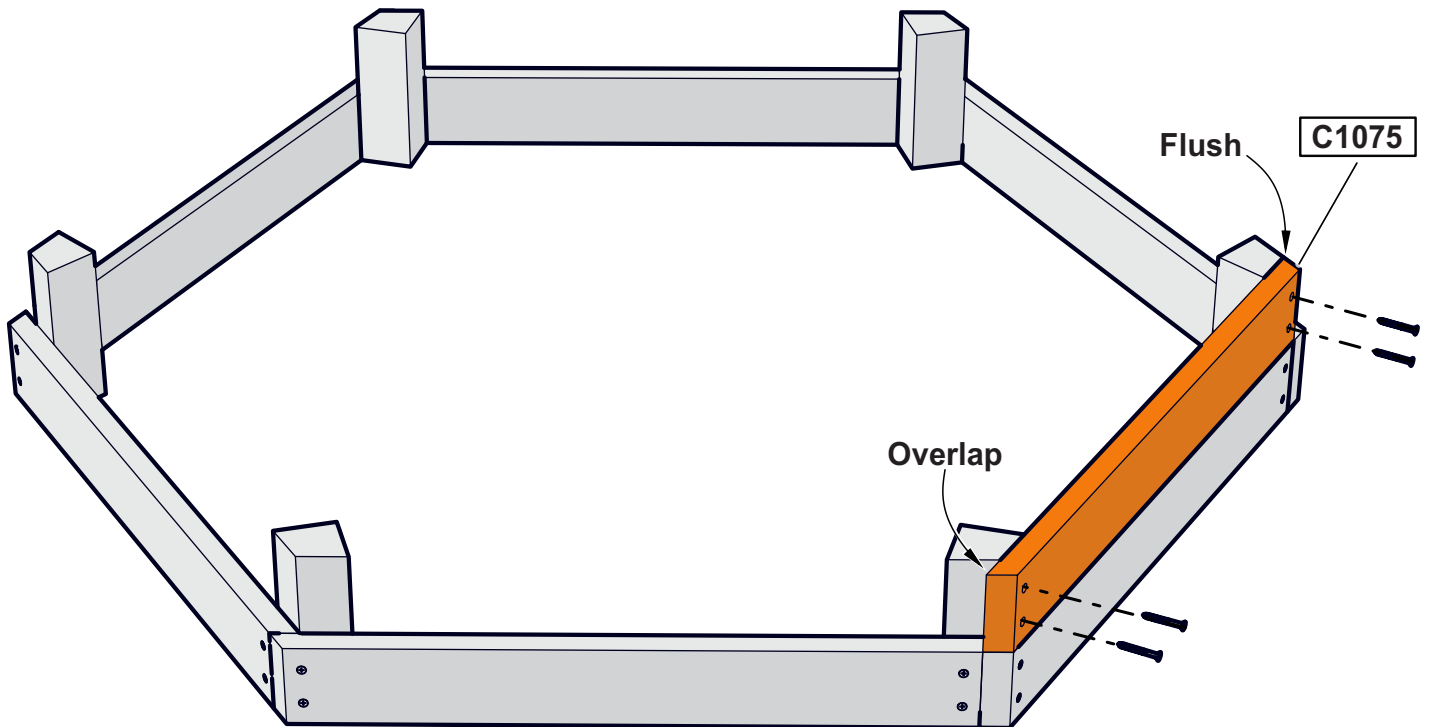



## STEP 8

Attach **C1075** board as shown.

### HARDWARE NEEDED (ACTUAL SIZE)



#8 X 1.625 WOOD SCREW  
QTY. 4

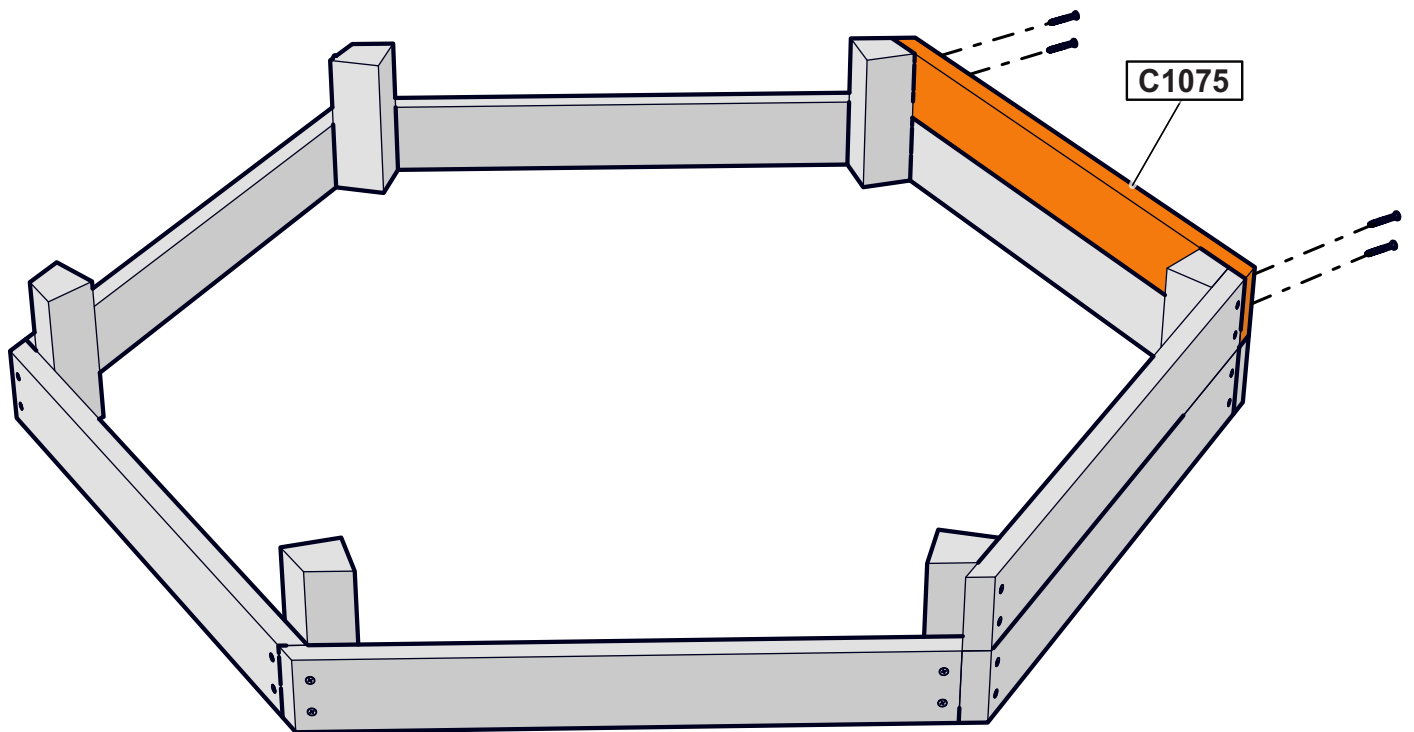

**HARDWARE NEEDED (ACTUAL SIZE)**



#8 X 1.625 WOOD SCREW  
QTY. 4

**STEP 9**

Attach **C1075** board as shown.

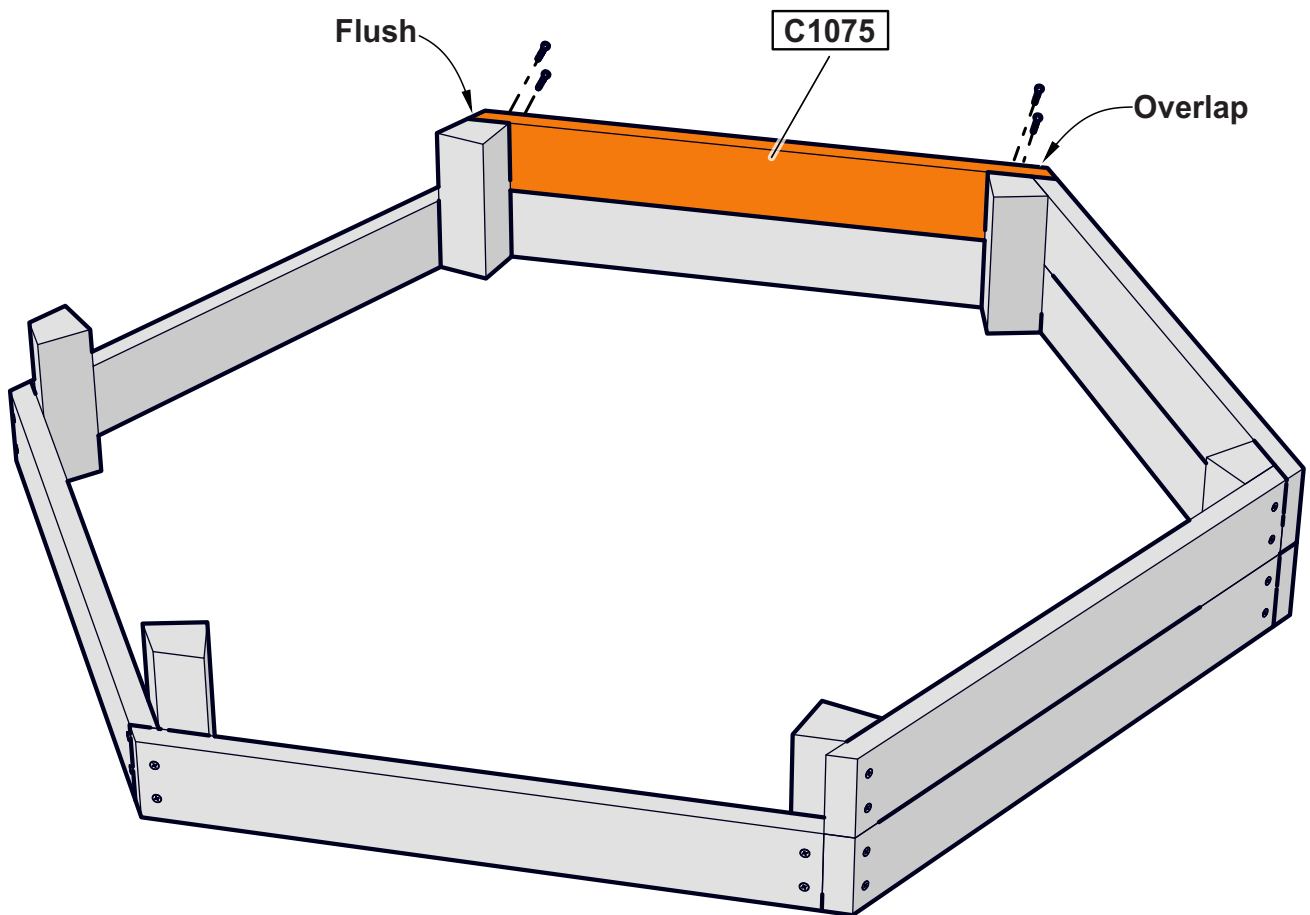

## STEP 10

Attach **C1075** board as shown.

### HARDWARE NEEDED (ACTUAL SIZE)



#8 X 1.625 WOOD SCREW  
QTY. 4

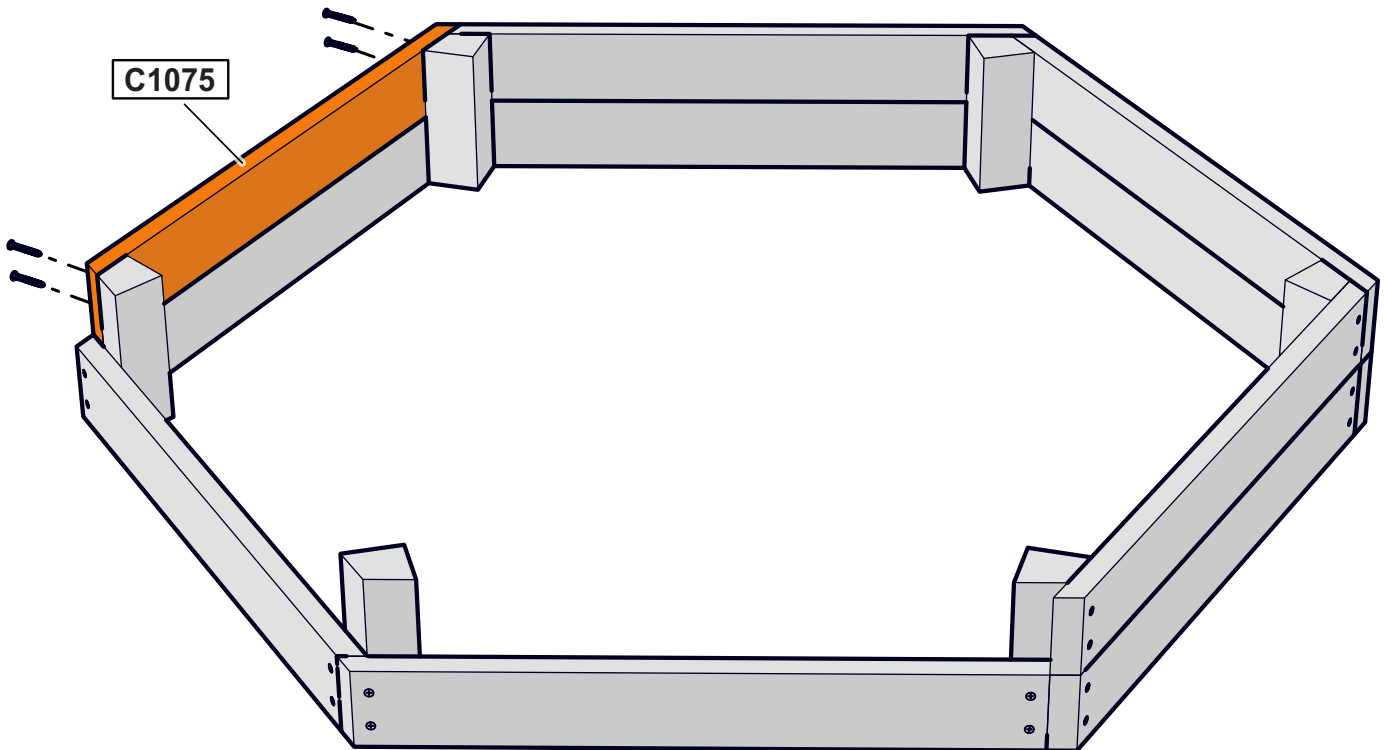

## STEP 11

Attach **C1075** board as shown.

### HARDWARE NEEDED (ACTUAL SIZE)



#8 X 1.625 WOOD SCREW  
QTY. 4

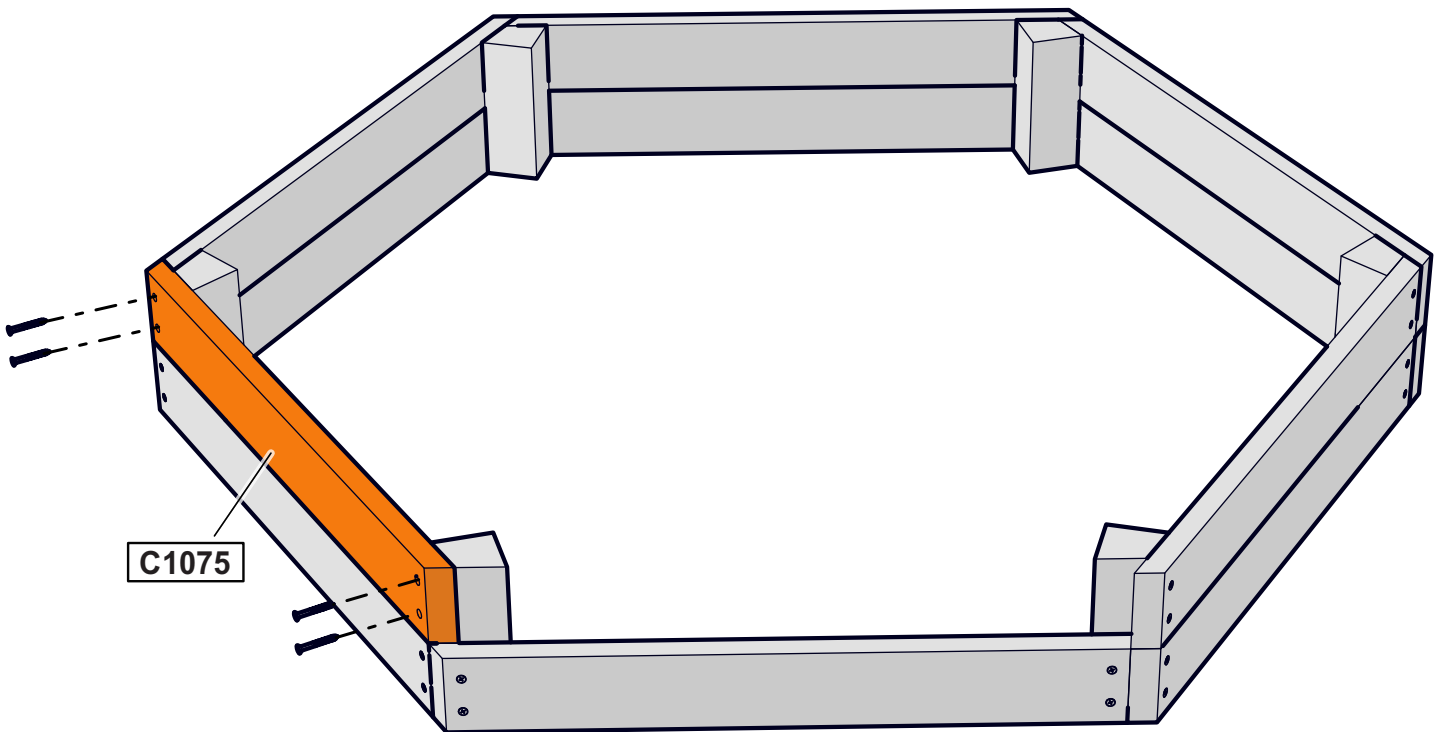

## STEP 12

Attach **C1075** board as shown.

### HARDWARE NEEDED (ACTUAL SIZE)



#8 X 1.625 WOOD SCREW  
QTY. 4

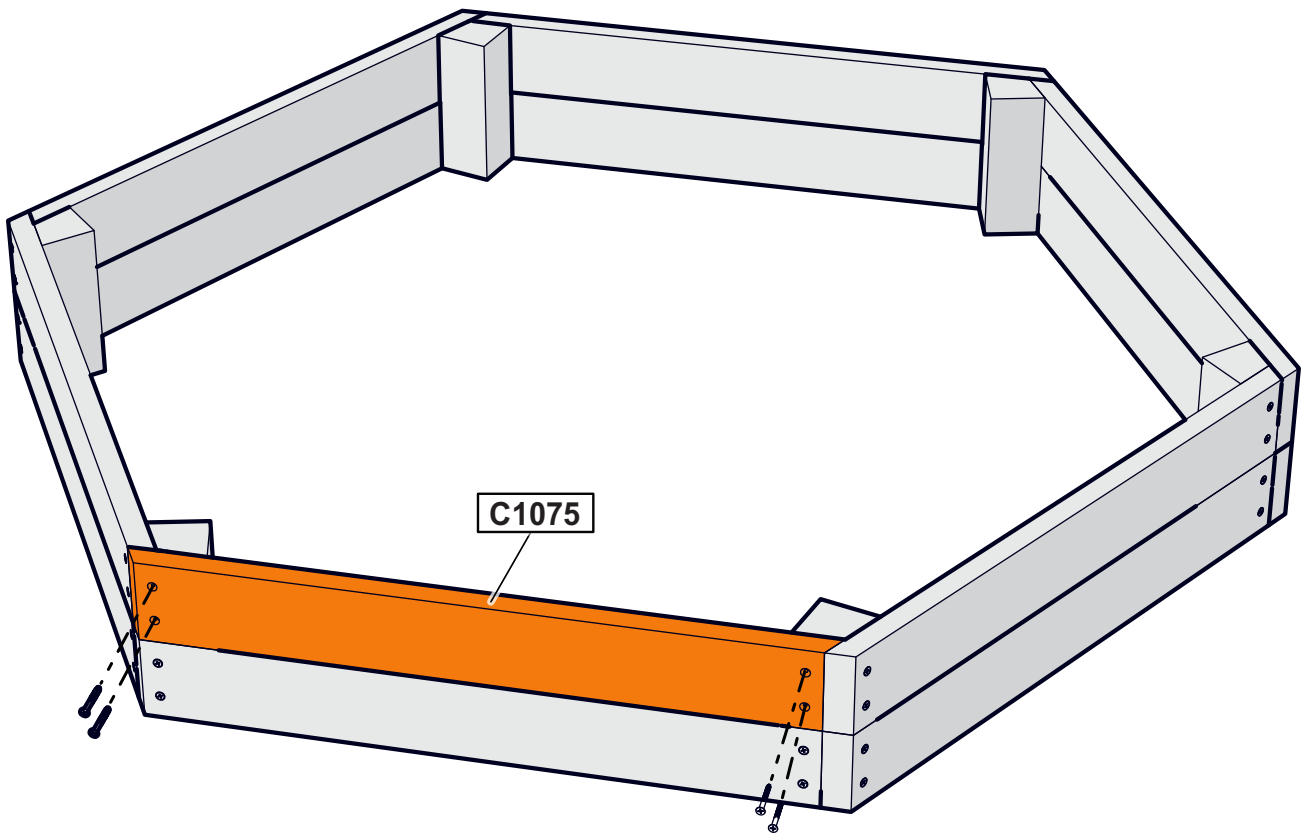

# STEP 13

Place three **C1077-2** Boards as shown but, do not screw down yet. Make sure Board **C1077-2** is flush with the **C1075** outer boards as shown in **Detail View** and **Side View**.

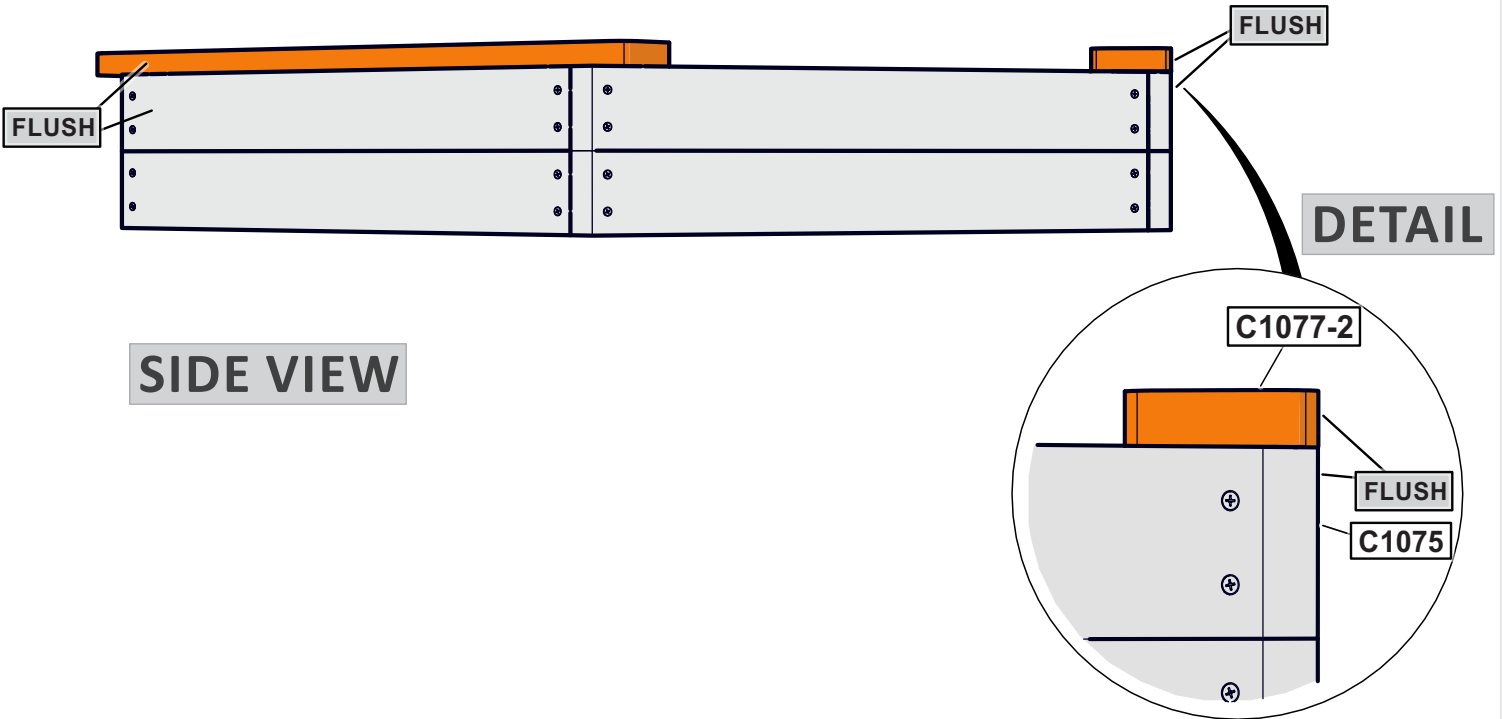
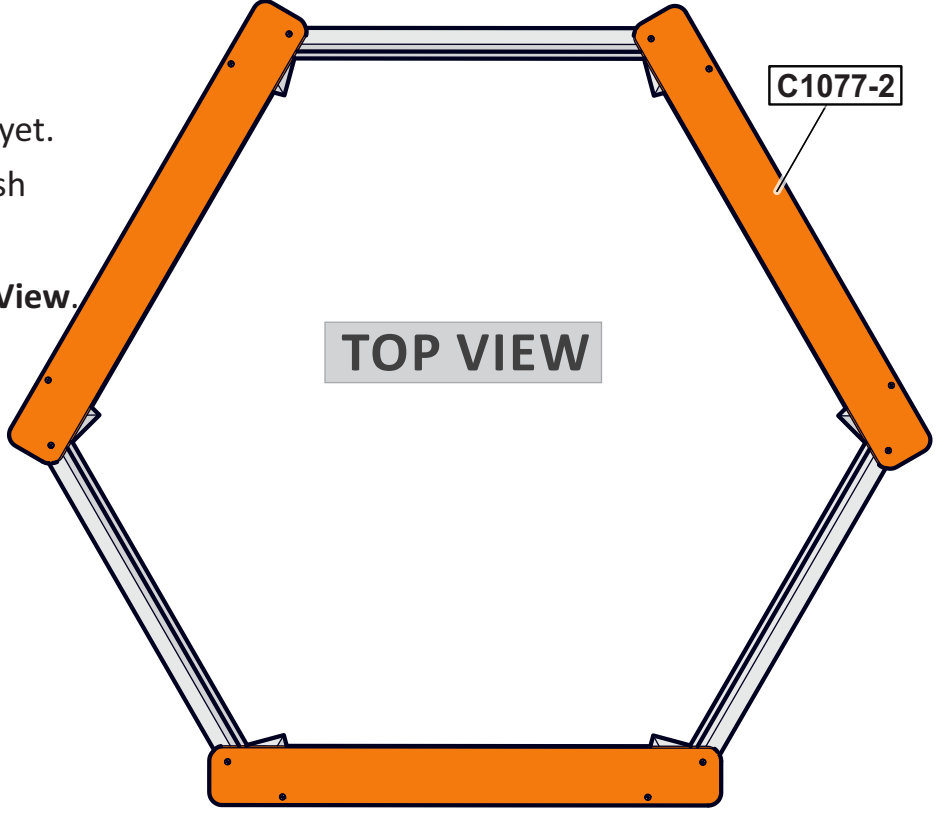

## STEP 14

Attach **C1077-2** boards to **C1075** Boards as shown. Make sure the screws are centered on top edge of **C1075** boards.

### HARDWARE NEEDED (ACTUAL SIZE)



#8 X 1.625 WOOD SCREW  
QTY. 12

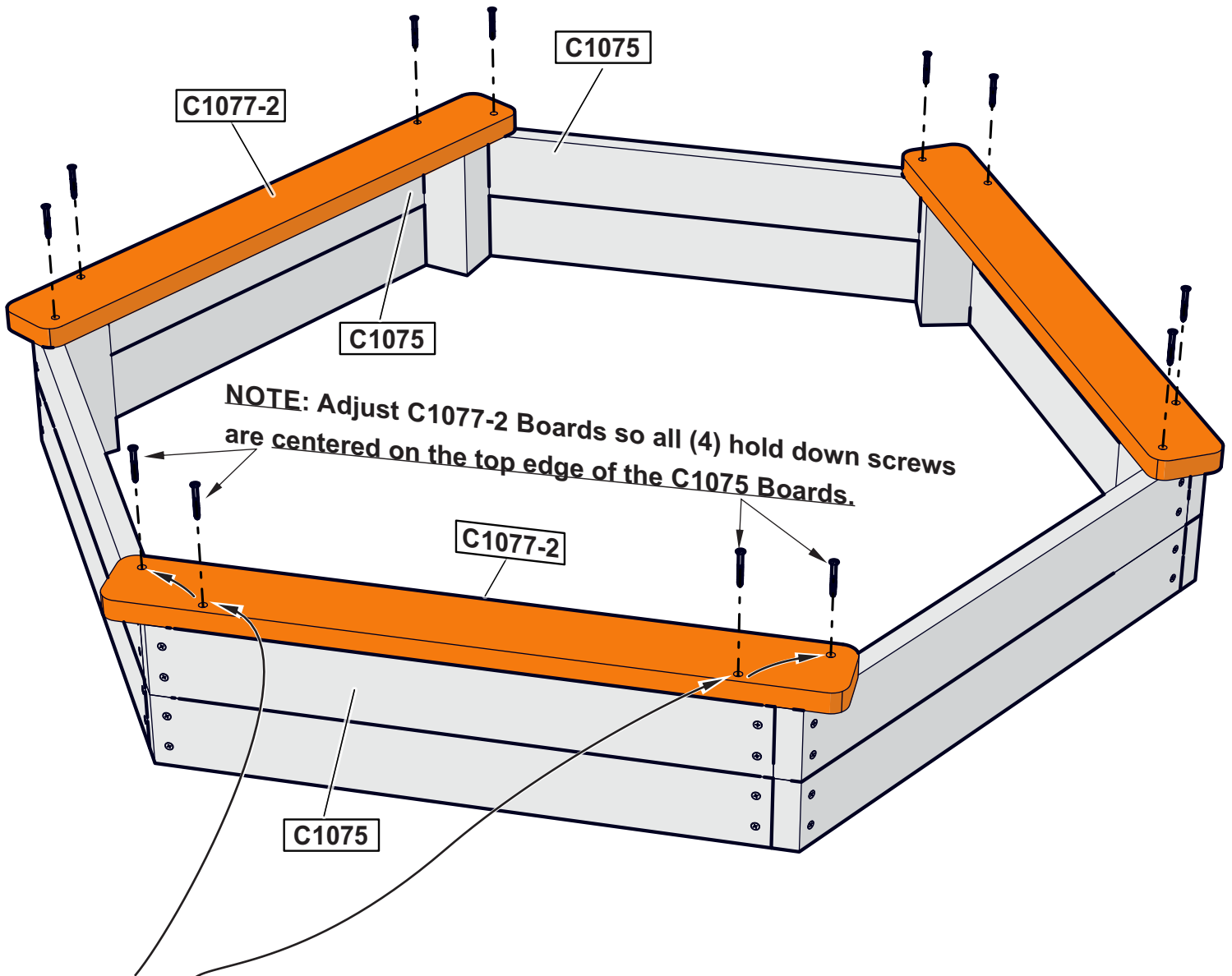

**NOTE:** Please place countersinks, in the **C1077-2** boards, for the #8 screw heads in the up/top position: #8 screws should be screwed in until **FLUSH**.

## STEP 15

Place tarp **D1090** at the bottom of the Sandbox as shown before adding sand.

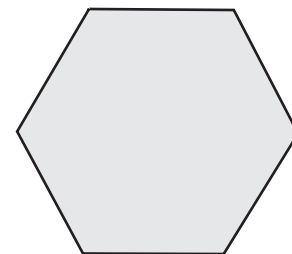

D1090  
QTY. 1

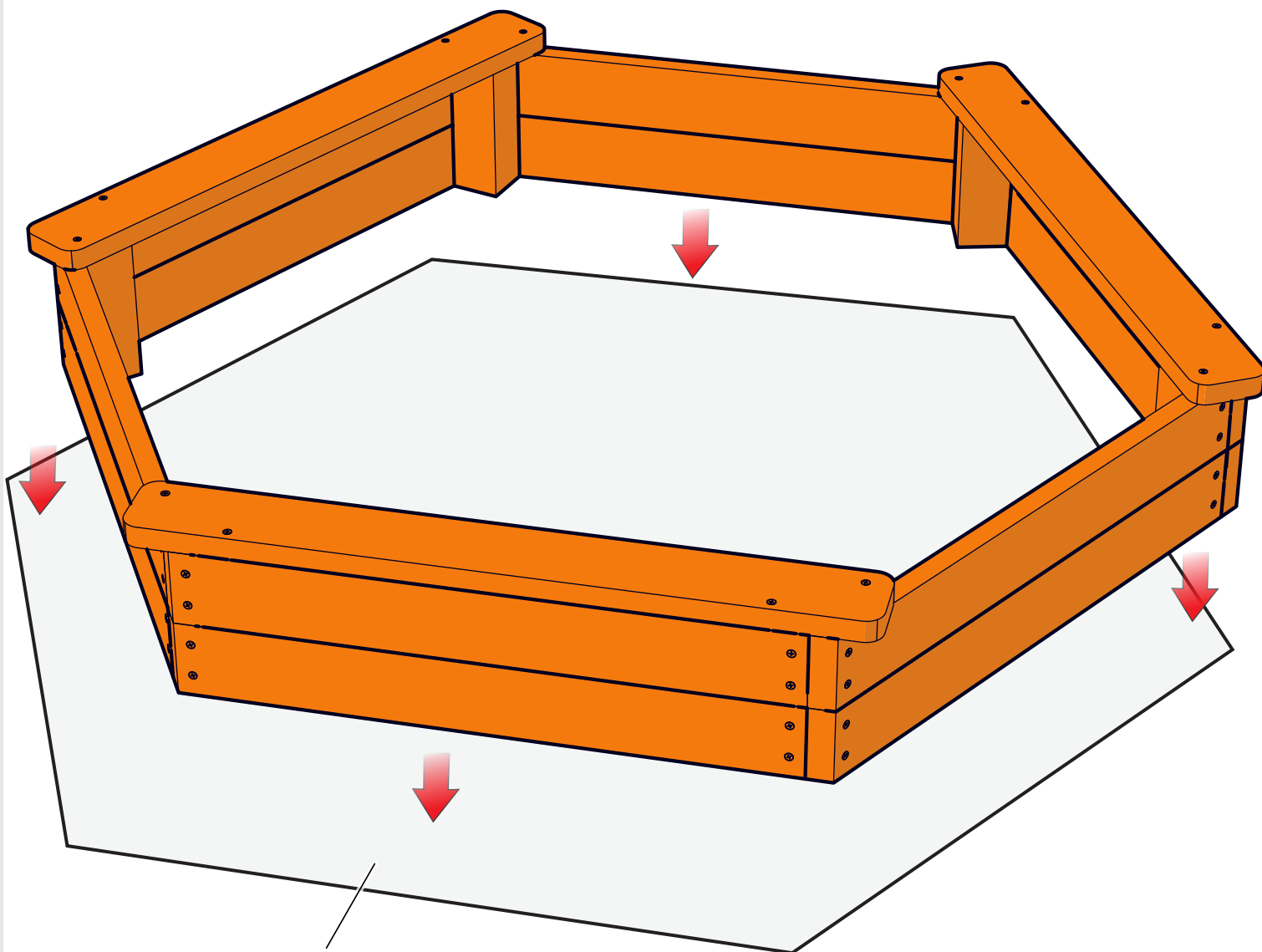

**D1090**  
Tarp for Sand