

Item 10700

ELECTRIC PATIENT LIFT

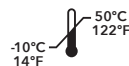

IPX4

Not made with natural rubber latex.

GENERAL INFORMATION

INTENDED USE

The Dynarex Electric Patient Lift is intended for use within an institutional healthcare environment, i.e. hospitals, nursing homes, rehabilitation care, assisted living.

The Dynarex Electric Patient Lift is NOT a transport device. It is intended to transfer an individual from one resting surface to another (such as a bed to a wheelchair).

SAFETY PRECAUTIONS

Assembling the lift

DO NOT overtighten the mounting hardware as this can damage the mounting brackets.

All hardware must be tight to ensure safe use of the Electric Patient Lift. All hardware and welds must be checked at least every six months in conjunction with periodic maintenance.

Operating the lift

DO NOT exceed maximum weight limitation of the patient lift. The weight limitation for 10700 is 450 lb. The weight limitation for 10701 is 600 lb.

ALWAYS ensure there is an audible click when mounting the battery on the battery charger to confirm proper mounting. Otherwise, injury or damage may occur.

ALWAYS keep hands and fingers away from moving parts to avoid injury.

Lifting the patient

The rear casters of the Electric Patient Lift MUST be kept unlocked when lifting an individual. Locking the casters during lifting procedures could cause the lift to tip and endanger the patient and

assistants. The unlocked casters during lifting procedures will allow the Electric Patient Lift to stabilize itself when the patient is initially lifted from a chair, bed or any stationary object.

Specific slings are made for the Electric Patient Lifts. For the safety of the patient, DO NOT intermix slings and patient lifts of different manufacturers. Warranty will be voided.

When the patient is elevated a few inches off a stationary surface and before moving the patient, check again to make sure that all hardware or straps are properly connected. If any attachment is NOT properly in place, lower the patient back onto the bed and rectify the issue.

Adjustments for safety and comfort should be made prior to moving the patient. Patient's arms should be kept inside of the straps.

During transfer, with patient suspended, DO NOT roll caster base over uneven surfaces that could cause the patient lift to tip over. Use steering handle on the mast at all times to maneuver the patient lift.

Performing maintenance

DO NOT attempt to open the pre-sealed actuator as it will VOID the warranty and might result in damage. Consult your dealer or manufacturer for further information.

Disposal

Device contains lithium batteries. DO NOT dispose of batteries in normal household waste. They MUST be taken to a proper disposal site. Contact your local waste management company for information.

EQUIPMENT ASSEMBLY

UNPACKING THE PATIENT LIFT

Main components provided in the package:

Not all items provided in the carton are shown. Pinch guards, bolts, washers and nuts are fastened to their intended locations and therefore omitted from the illustration. Unless the lift is to be used immediately, retain boxes, containers, and packing materials for use in storing until use of patient lift is required.

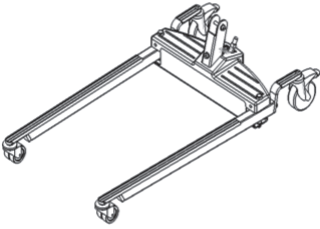

Lift Caster Base × 1

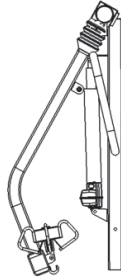

Boom/Mast Assembly × 1

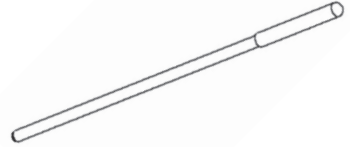

Shifter Handle × 1

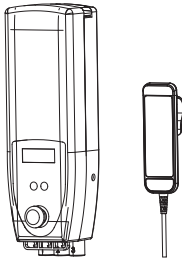

Control Box & Hand Pendant × 1



Charging Power Cord × 1

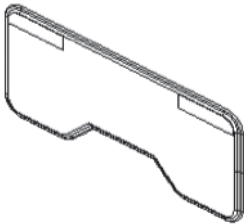

Swivel Bar Protective Cover × 1



Also provided in the package:
Allen Wrench × 2 (size M8 & M10)

You should prepare the following tools for the lift assembly:

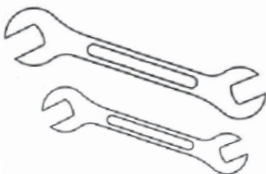

Wrench × 2 (size M8 & M10)



Phillips Screwdriver × 1

ASSEMBLING THE PATIENT LIFT

Assembling the mast to the base

1. Step on the locking levers to lock the two rear casters at the base.
2. Remove the bolts, washers and nuts fastened to the base of the mast.
3. Position the mast in an upright position and place the mast over the U-shape cut-out of the base.
4. Insert bolts with washers through the base and mast.
5. Secure with nuts.

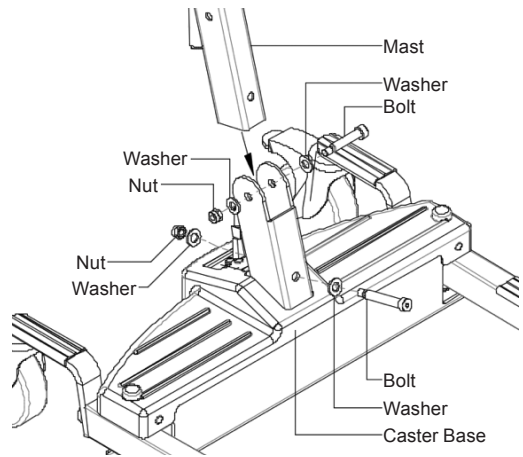

Assembling the electric actuator to the boom

1. Remove the bolt, washer and nut fastened to the boom mounting bracket.
2. Lift up on the boom and place it on your left shoulder.
3. Lift the boom actuator shaft extension until it lines up with the mounting holes in the boom assembly.
4. Align the holes of the boom assembly mounting bracket with those of the boom actuator and insert the bolt. Secure with nut.

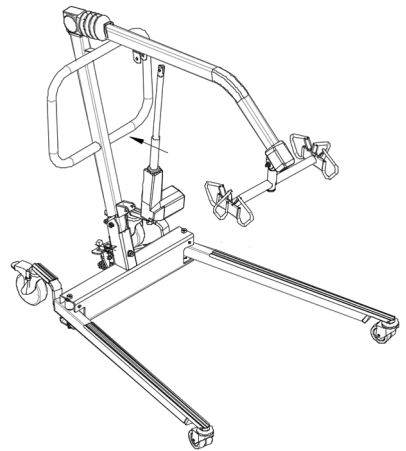

NOTE: Be sure that the bolt is completely through the holes of the boom assembly mounting bracket and the actuator assembly. The boom assembly will pivot easily if the mounting hardware is aligned properly when the boom assembly is secured.

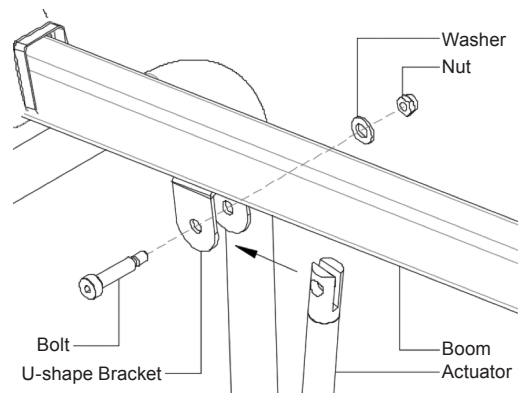

Assembling the control box to the mast

1. Slide the control box onto the mounting bracket on the boom. Make sure the control box is held by the slide track.
2. With one hand holding down the control box, plug the actuator cord to the control box. The hand pendant should already be connected.

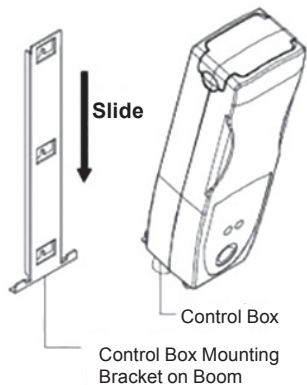

Installing the shifter handle

1. Line up the shifter handle opening with the threaded connector at the base.
2. Turn the shifter handle clockwise and securely tighten into the base.

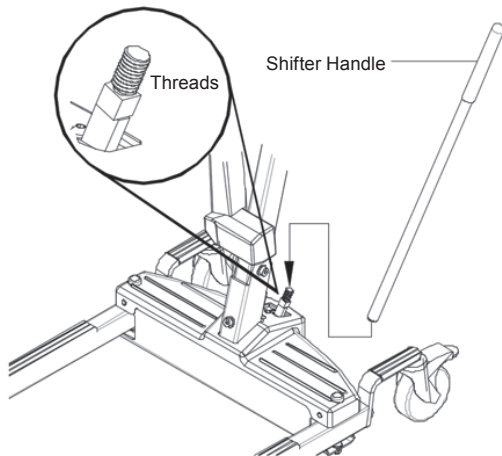

FRONT VIEW

SIDE VIEW

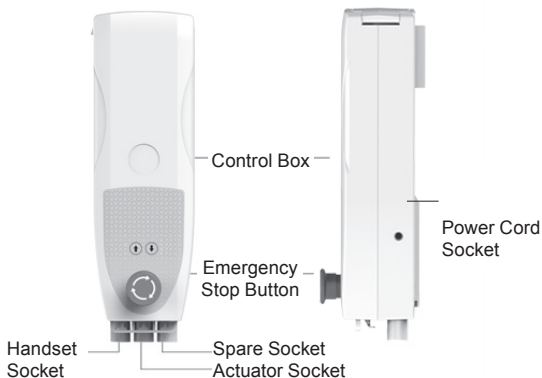

EQUIPMENT OPERATION

OPERATING THE PATIENT LIFT

Closing/opening the legs of the lift base

Stand at the rear of the lift and grasp the shifter handle. Swivel the shifter handle to open and close the legs of the base.

The shifter handle **MUST** be positioned completely into its mounting slot. **DO NOT** use the patient lift until the patient is properly seated and the legs of the patient lift are locked in place. Otherwise, injury and/or damage may occur.

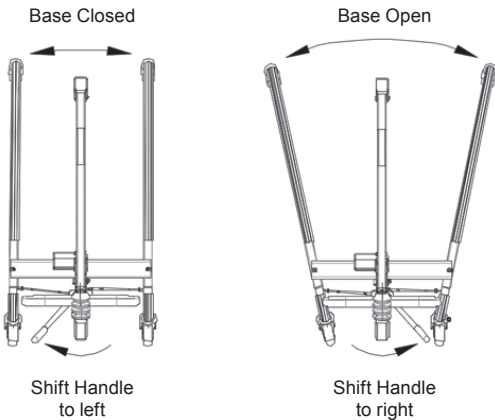

Raising/Lowering the Electric Patient Lift

To raise the patient lift, press the UP button (▲ up arrow) to raise the boom and the patient.

To lower the patient lift, press the DOWN button (▼ down arrow) to lower the boom and the patient.



Activating the emergency stop

Press the RED emergency button on the control box to stop the boom assembly and patient from raising or lowering. Rotate the RED emergency stop button clockwise to disengage the emergency stop.

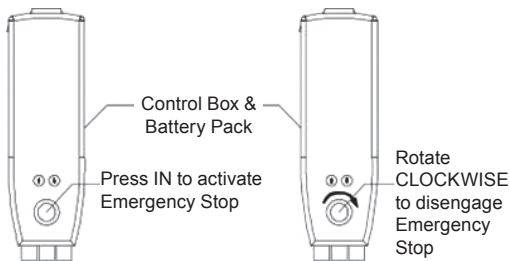

Charging the battery

It is recommended that the battery should be recharged daily to prolong battery life. The battery status can be viewed on the LCD display at the front of the control box.

Charging the battery with power cord

Insert one end of the power cord into the corresponding socket on the underside of the control box. Plug the other end into an appropriate grounded electrical socket.

The indication light on the control box will be illuminated to indicate the battery is being charged.

NOTE: The lift will not be operable while the battery is being charged. Keep the lift casters locked and lift stationary.

SIDE VIEW

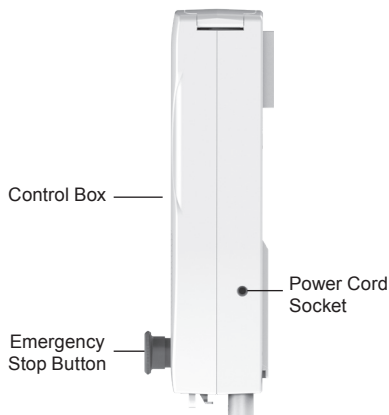

Mounting a wall charger

The wall charger is an accessory and should be ordered separately.

LIFTING THE PATIENT

PREPARING THE LIFT FOR USE

Positioning the lift for use

1. With the legs of the base open, use the steering handle to push the patient lift into position.
2. Lower the patient lift for easy attachment of the sling.

NOTE: The legs of the lift must be in the maximum open position and the shifter handle locked in place for optimum stability and safety. If it is necessary to close the legs of the lift to maneuver the lift under a bed, close the legs of the lift only as long as it takes to position the lift over the patient and lift the patient off the surface of the bed. When the legs of the lift are no longer under the bed, return the legs of the lift to the maximum open position and lock the shifter handle immediately.

Prepare the sling for patient in lying position

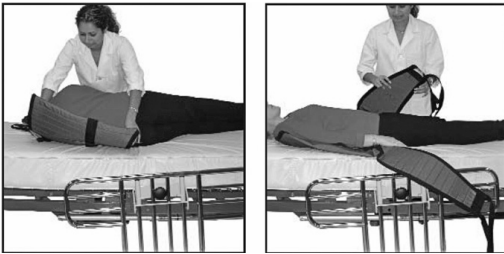

1. Carefully and gently roll the patient on their side. The sling seat should be folded lengthwise and placed under the patient so that the lower edge of the seat is slightly below the back.
2. Roll the patient back onto their other side and pull the sling seat so that it unfolds under the patient.

Prepare the sling for patient in seated position



WARNING: When the patient is seated in a wheelchair, the wheels **MUST** be locked when putting on the sling.

1. Lean patient forward and set the divided leg sling behind the patient's back. Set the sling as far down as possible until it touches the back of the seat.
2. Pull the leg loops forward and under the patient's thighs. The loops should come through the patient's legs. Then cross the loops.

Lifting/moving the patient

WARNING: Before lifting or transferring the patient, the base legs **MUST** be in the open position for optimum stability and safety. **DO NOT** engage the rear locking casters when patient is in the lift.

NOTE: The loops of the sling are color coded. The colors make it easy to connect both sides of the sling equally. Make sure that there is sufficient head support when lifting a patient.

1. With the lift in position and boom lowered, place the straps of the sling over hooks of the swivel bar. With the sling securely attached to the lift, press the UP (▲) button to raise the patient above the bed.

The patient should be elevated high enough to clear the bed and their weight supported by the lift.

2. When the patient is lifted from the bed (with the patient's head supported), he/she will be raised to a sitting position.
3. When the patient is clear of the bed surface, swing their feet off the bed.
4. Using the steering handle, move the lift away from the bed.
5. When moving the patient lift away from the bed, turn the patient so that he/she faces assistant operating the patient lift.

TRANSFERRING THE PATIENT

Transferring the patient to a wheelchair

WARNING: The wheelchair wheels **MUST** be locked before lowering the patient into the wheelchair for transport.

1. The legs of the lift (with patient) should be in open position.
2. Move the wheelchair into position.
3. Ensure the rear wheels of the wheelchair are locked to prevent further movement of the chair.

4. Position the patient over the seat with their face away from the seat and their back against the back of the chair.

Use the straps or handles on the side and the back of the sling to guide the patient's hips as far back as possible into the seat for proper positioning.

5. Lower the patient by pressing the **DOWN (▼)** button on the lift controller.
6. With one assistant behind the chair and the other operating the patient lift, the assistant behind the chair will pull back on the grab handle (on select models) or sides of the sling to seat the patient well into the back of the chair. This will maintain a good center of balance and prevent the chair from tipping forward.
7. Disconnect the sling from the patient lift.

To return to the bed, reverse procedures concerning lifting the patient, operation and sling attachments.

TROUBLESHOOTING GUIDE

SYMPTOMS	FAULTS	SOLUTIONS
Actuator idle when lift buttons are pressed.	Battery low.	Recharge battery with power cable or wall charger.
	Hand control or actuator connector loose.	Ensure tight connection of all connectors to control box.
	RED emergency stop button pressed in.	Rotate the emergency button clockwise until it pops out.
	Battery not connected properly to control box.	Dismount and remount the battery to control box.
	The connecting terminals are damaged.	Replace the battery pack. Contact your supplier.
	Actuator in need of service or load is too high.	Contact your supplier for actuator maintenance.
Patient lift feels loose.	Mast/base joint loose. Tie-Rods are loose.	Refer to page 4.
Casters/brakes noisy or stiff.	Debris or fluff in bearings	Replace casters.
Noisy or dry sound from pivots.	Needs lubrication.	Lubricate your lift.
Unusual noise from actuator.	Actuator is worn or damaged or spindle is bent.	Replace the actuator. Contact your supplier.
Lift arms will not lower when emergency release is pressed.	Lift arms require a minimum weight load to lower during emergency release.	Pull down slightly on the lift arms.

If problems persist following the above remedial procedures, please contact your dealer or the manufacturer.

WARRANTY

Your Dynarex Electric Patient Lift is warranted to be free of defects in materials and workmanship for five (5) years on structural steel, one (1) year on electrical & mechanical parts/components, from original date of purchase, for use by the original purchaser. This item was built to exacting standards and carefully inspected prior to shipment. This Warranty is an expression of our confidence in the materials and workmanship of our products and our assurance to the consumer of dependable service.

The Warranty shall not apply under the following conditions:

- Problems arising from normal wear
- Problems arising from failure to adhere to the product instructions
- Problems arising from misuse, negligence, accident or improper operation, maintenance or storage
- Problems arising from modifications or unauthorized repairs, parts or attachments
- Products where the serial number has been removed or defaced
- Problems with non-durable components, such as rubber accessories, casters, and grips, which are subject to normal wear and need periodic replacement

Dynarex shall not be liable for any consequential or incidental damages whatsoever. Dynarex shall repair or replace defective products at its option. The foregoing warranty is exclusive and in lieu of other express warranties, if any, including the implied warranties of merchantability and fitness of a particular purpose. The remedy for any violation of the implied warranty shall be limited to repair or replacement of the defective product pursuant to the terms contained herein.

If you have a question about your Dynarex device or this warranty, please contact an authorized Dynarex dealer.

Manufactured for: Dynarex Corporation
11 Dynarex Drive • Middletown, NY 10941
USA • www.dynarex.com
Symbol Glossary: dynarex.com/symbols.php
Made in China R250130

 **WARNING:**
Cancer and Reproductive Harm
www.P65Warnings.ca.gov