

Installation Instructions

Touchless Soap Dispenser Battery Power

Record your model number:

Noter le numéro de modèle:

Anote su número de modelo: _____

Français, page 27

Español, página 56

KOHLER®

Thank You for Choosing KOHLER

Need help? Contact our Customer Care Center.

- USA/Canada: 1-800-4KOHLER (1-800-456-4537) Mexico: 001-800-456-4537
Hours of Operation: Monday-Friday 8:00 AM -5:00 PM (CT)
Languages Spoken: English, Spanish, and translation services are available.
- **Service parts:** [kohler.com/serviceparts](https://www.kohler.com/serviceparts)
- **Care and cleaning:** [kohler.com/clean](https://www.kohler.com/clean)
- **Patents:** [kohlercompany.com/patents](https://www.kohlercompany.com/patents)

Warranty

This product is covered under the **KOHLER® One-Year Limited Warranty**, found at [kohler.com/warranty](https://www.kohler.com/warranty). For a hardcopy of warranty terms, contact the Customer Care Center.

Tools and Materials

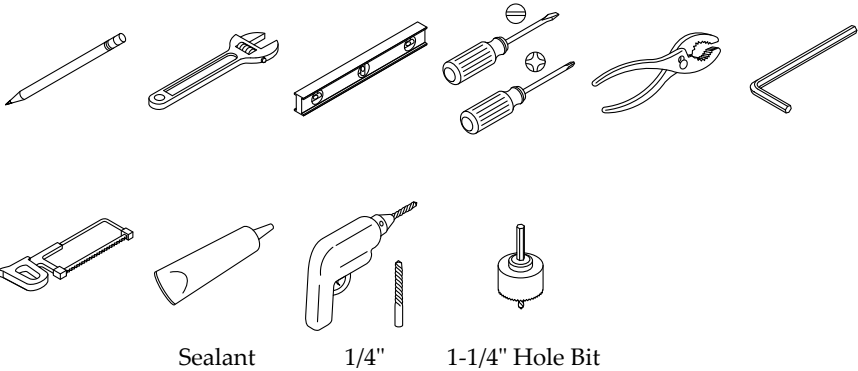

Plus:

- Wood Brace Materials
- Woodworking Tools
- #8 Wood Screws
- 1-1/2" Schedule 40 PVC Pipe and 90 Degree Elbow
- U-Clamp
- Electrical Tape
- Foaming Hand Soap (1 cP – 100 cP Dynamic Viscosity)

Before You Begin

IMPORTANT! Your product may appear different than illustrated. The installation procedure is the same. Refer to the Specification Sheet for roughing-in dimensions for your model requirements.

Follow all local plumbing and building codes.

Soap Requirements



CAUTION: Risk of product damage. The foaming hand soap must have a dynamic viscosity rating between 1 centipoise – 100 centipoise (cP) measured in cP or grams/cm-s units. Soaps with a dynamic viscosity greater than 100 cP can cause premature wear and damage to the soap dispenser components.



CAUTION: Risk of product damage. Only use liquid foaming hand soap that contains no suspended particles or microbeads. Do not use nonfoaming liquid hand soaps, which typically have a dynamic viscosity rating of 1000 cP – 3500 cP.



CAUTION: Risk of product damage. Do not use alcohol-based soap and/or soaps with alcohol.

IMPORTANT! For normal functioning, the soap dispenser sensor must be pointed into the sink and not to the counter top/deck.

IMPORTANT! Soap should be added only when the product will be under normal usage. Do not fill the soap reservoir when the soap dispenser will not be used for extended periods of time (weeks or months) after the initial installation.

NOTE: KOHLER brand foaming hand soaps are precisely formulated to work with this product and have a dynamic viscosity rating of 1 cP – 100 cP.

NOTE: See kohler.com for more information on recommended foaming hand soaps. Precise information on soap material properties and dynamic viscosity rating can be found on the soap manufacturers published material safety data sheets.

Roughing-In

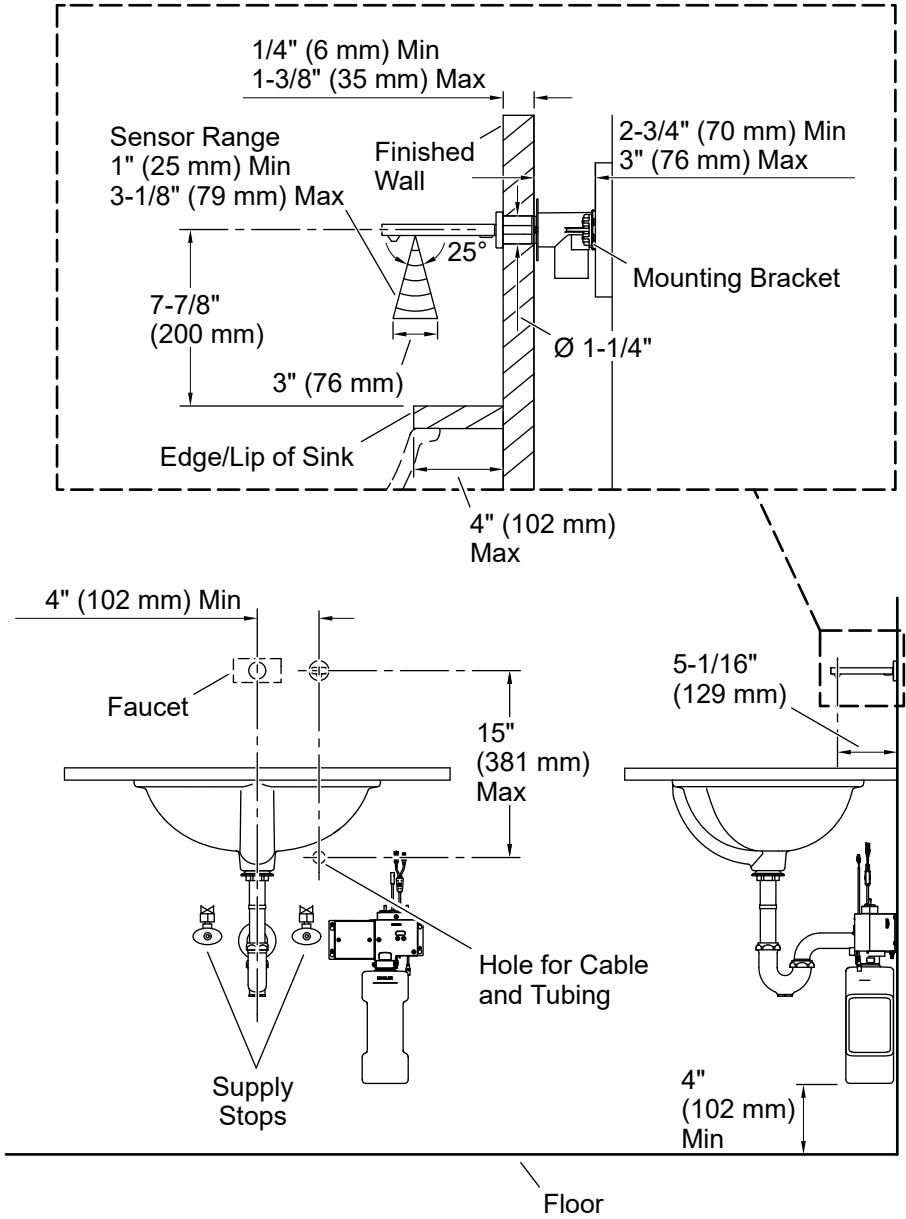

1. Install the Mounting Bracket

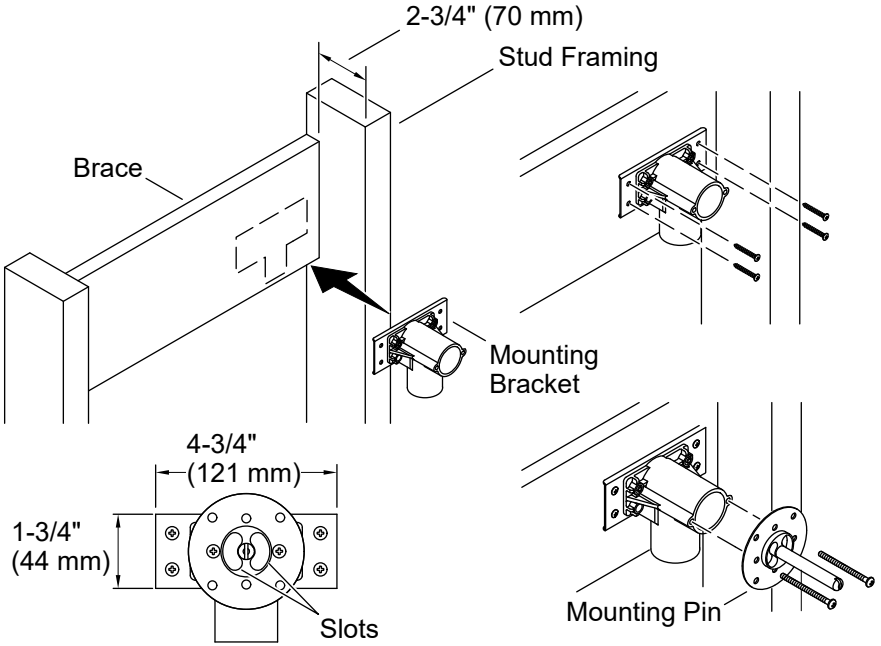

IMPORTANT! Your product may appear different than illustrated. The installation procedure is the same. Refer to the Specification Sheet for roughing-in dimensions for your model requirements.

- Construct the framing for your installation.
- Secure the mounting bracket to the brace using four wood screws – size #8.
- Remove the plaster guard.

NOTE: Verify the slot orientation as shown above.

- Secure the mounting pin to the mounting bracket using the two screws provided.

2. Install the Piping (Recommended)

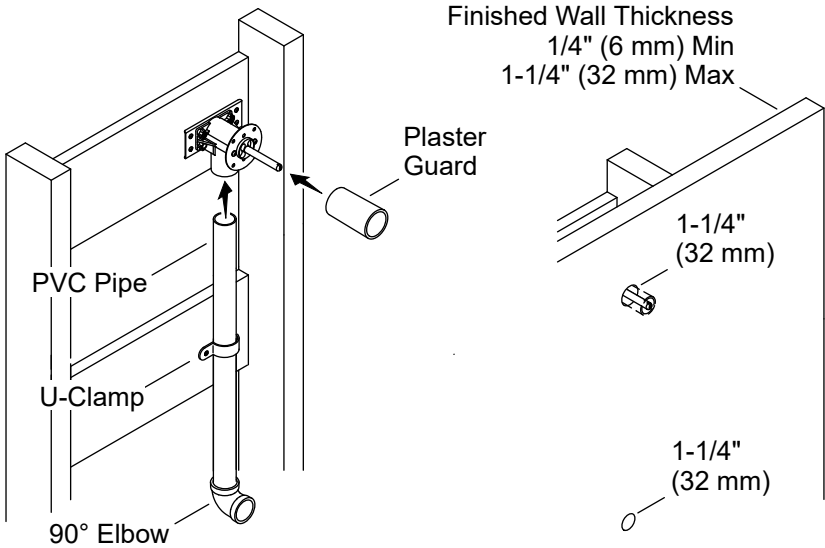

NOTE: PVC fittings and PVC pipes (not provided) can be attached to the mounting bracket to route the spout cables and tubes to the control box. Refer to the Specification Sheet to determine the control box location.

- Connect a straight PVC pipe to the mounting bracket as shown. Verify that the tube is long enough to reach the control box.
- Secure the PVC pipe onto the mounting bracket with U-clamps (not provided).
- Glue a 90 degree PVC elbow at the end of the PVC pipe at the control box installation location.
- Reinstall the plaster guard over the mounting pin.

NOTE: The finished wall thickness must be 1/4" (6 mm) minimum to 1-1/4" (32 mm) maximum.

- Finish the wall with a 1-1/4" (32 mm) hole for the spout.
- Finish the wall with a 1-1/4" (32 mm) hole for the cables and tubing.

3. Prepare the Spout

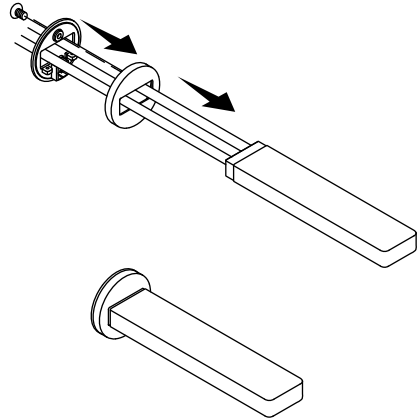
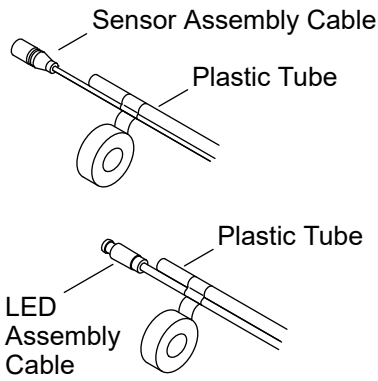

- For ease when routing the cables and tubes, use electrical tape to secure one of the cables to one of the tubes. Repeat for the remaining cable and tube.

NOTE: Do not damage the spout finish while installing the escutcheon.

- Route the cables and tubes through the escutcheon to install the escutcheon onto the spout.

4. Secure the Spout

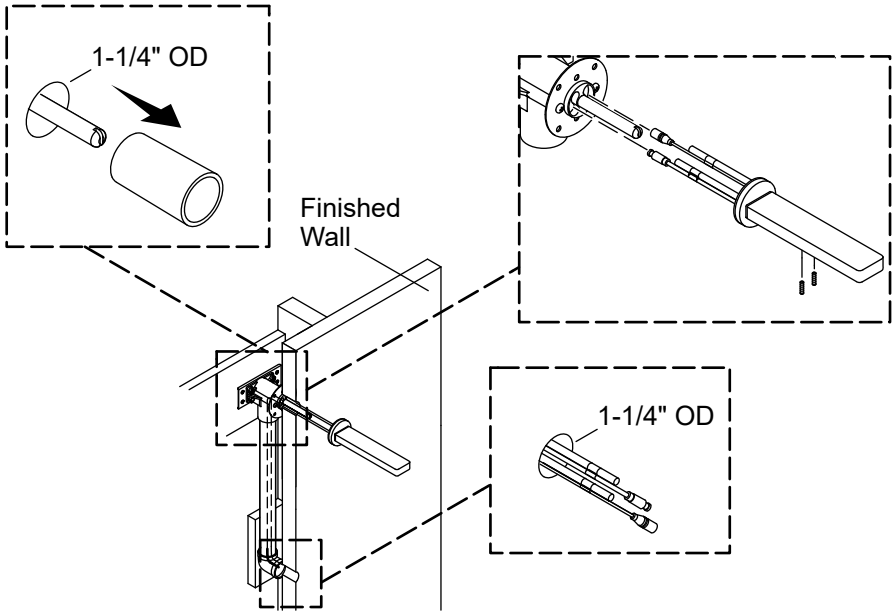

NOTE: The soap dispenser sensor must be pointed toward the sink and not toward the deck to properly function.

- Remove the plaster guard.

NOTE: Avoid pinching and twisting the cables and tubes when installing the spout.

- Feed the cables and tubes from the spout through the mounting bracket and down through the PVC tubing.
- Slide the spout assembly onto the mounting pin until flush with the wall.
- Pull the cables and tubes from the spout out through the hole leading to the control box location.
- If desired, add sealant to the underside of the escutcheon. Wipe away excess sealant.
- Tighten the two setscrews (provided) to secure the spout to the mounting bracket.

5. Install the Control Box

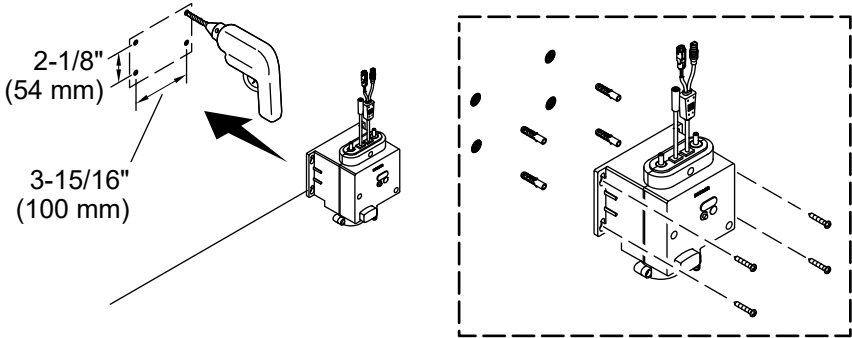

NOTE: A minimum 4" (102 mm) clearance is needed between the soap reservoir and the inside cabinet/floor. See the Specification Sheet for the control box location.

NOTE: The provided wall anchors are for concrete wall installation. Use the appropriate wall anchors for your wall material.

- Mark the location of the mounting holes.
- Drill the holes per the anchor manufacturers instructions. If using the provided wall anchors, drill 1/4" (6 mm) pilot holes.
- Attach the control box to the wall as shown.
- Secure with the four screws provided.

6. Install the DC Power Unit

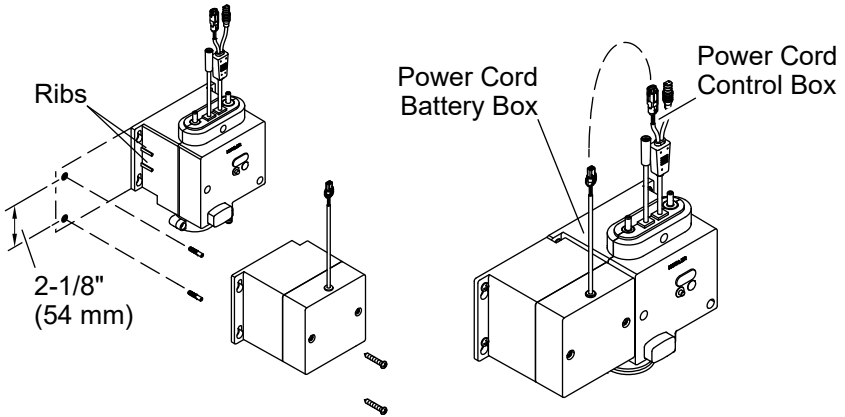

NOTE: The provided wall anchors are for concrete wall installation. Use the appropriate wall anchors for your wall material.

NOTE: Do not mix used and new batteries.

- Unthread the screws from the battery box to remove the battery box cover.
- Insert four D batteries (provided). Reinstall the battery box cover and secure with the screws.
- Align the grooves on the battery box with the ribs on the side of the control box.
- Mark the location of the mounting holes.
- Drill the holes per the anchor manufacturers instructions. If using the provided wall anchors, drill 1/4" (6 mm) pilot holes.
- Slide the battery box onto the ribs on the side of the control box. Secure with the screws.

7. Connect the Control Box Wires

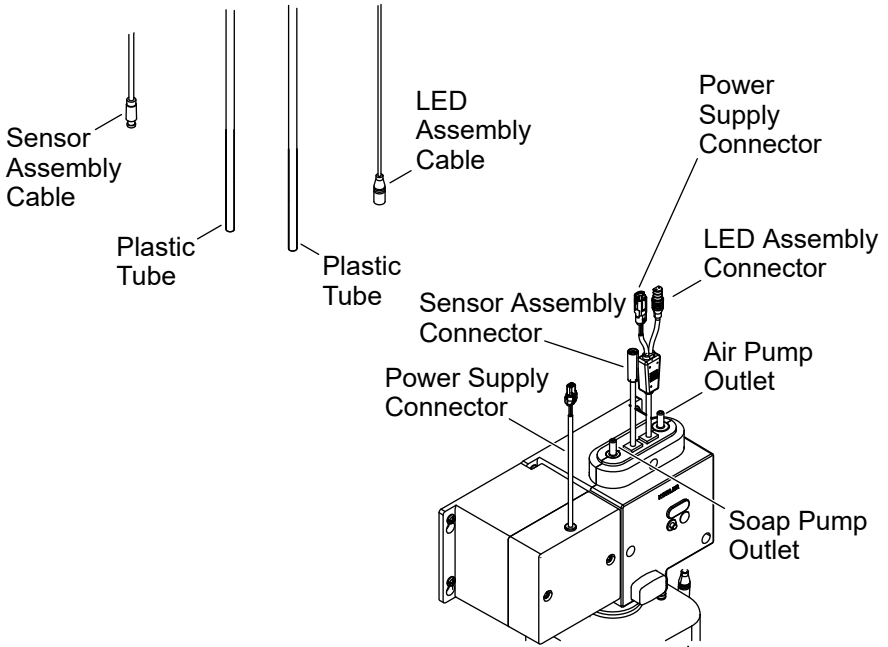

IMPORTANT! Verify that the cables are not pinched when connecting to the control box.

IMPORTANT! The area in front of the sensor must be free of objects during the 2 minute learning cycle or the soap dispenser may not function properly.

- Connect the sensor assembly cable from the spout to the sensor assembly connector from the control box.
- Connect the LED assembly cable from the spout to the LED assembly connector from the control box.
- Connect the power supply connector from the battery box to the power supply connector from the control box.
- Allow 2 minutes for the sensor to cycle through the automatic sensing distance.

NOTE: When the power source is connected, the LED at the base of the spout will turn BLUE for 1.5 seconds, and then RED for 1.5 seconds. This confirms that all required cable connections have been completed.

NOTE: The default sensor range is $2.75" \pm 0.275"$ (70mm \pm 7mm) after power is connected. To change sensor range, follow the steps in the "Self-Learning Sensor Range Adjustment" section.

- Secure any extra wire under the deck.

8. Connect the Tubes

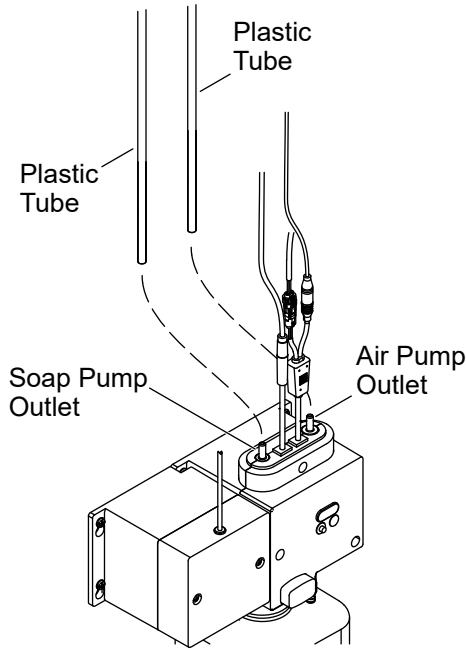

IMPORTANT! Verify that the tubes are not pinched when connecting the control box outlets. Do not coil or loop the extra tubing.

NOTE: The plastic tubes are interchangeable. Either tube can be connected to the soap or air pump outlet.

Soap Pump Connections

- Verify that the plastic tube from the spout is the appropriate length to reach the control box.
- The tube should not hang below the outlet of the control box. Cut the tube if necessary.
- Press the plastic tube onto the soap pump outlet on the control box until the tube stops.
- Verify that the tube is secure.

Air Pump Connections

- Verify that the plastic tube from the spout is the appropriate length to reach the control box.
- The tube should not hang below the outlet of the control box. Cut the tube if necessary.
- Press the remaining plastic tube onto the air pump outlet on the control box until the tube stops.
- Verify that the tube is secure.

9. Fill the Soap Reservoir

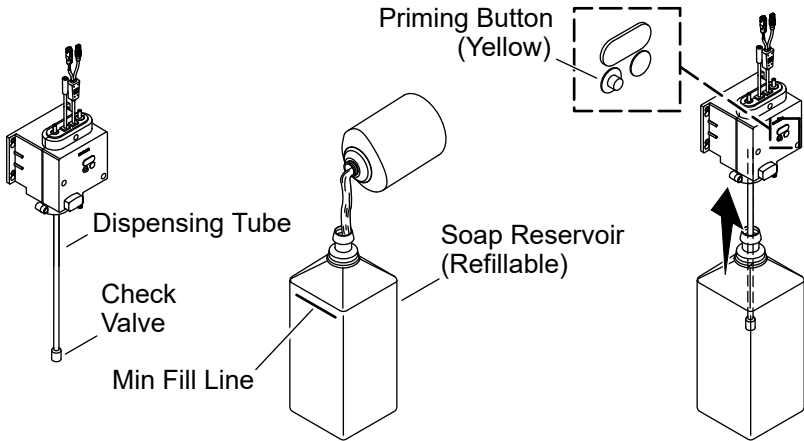

CAUTION: Risk of product damage. Fill the soap reservoir with soap only when the building is commissioned/opened and construction is completed. Do not fill the soap reservoir when the soap dispenser will not be used for extended periods of time (weeks or months) after the initial installation. If necessary, use clean warm water to test the soap dispenser function. Empty the soap reservoir after test.

IMPORTANT! Rinse the inside of the empty soap reservoir with clean warm water before first use.

NOTE: The 1600 ml soap reservoir is included. Refer to kohler.com/serviceparts for the optional 800 ml soap reservoir.

NOTE: Refer to the “Soap Requirements” section for more information on the soap requirements for this product.

- Fill the soap reservoir with KOHLER brand foaming hand soap or foaming hand soap with 1cP – 100 cP to the “Min Fill” line. Do not overfill the soap reservoir.
- Insert the dispensing tube from the control unit into the soap reservoir.
- Press the soap reservoir into place until an audible click is heard.
- Press the yellow priming button located on the control unit after each soap refill until the soap streams out of the spout nozzle (approximately 10 seconds).

10. Set the Volume of Soap Dispensed

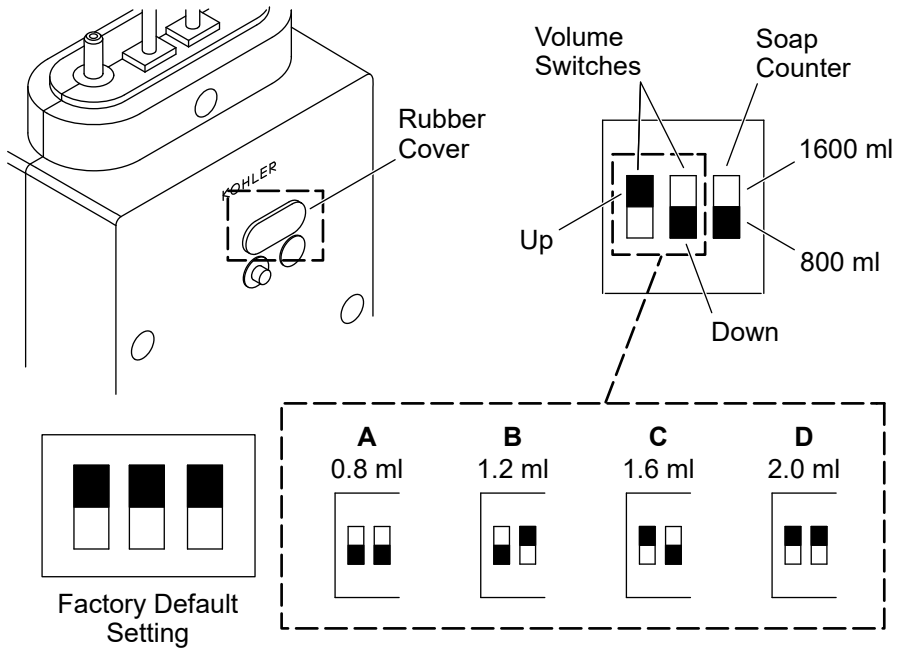

IMPORTANT! Four options are available to control the amount of soap dispensed. The desired option is set by moving the volume switches to an up or down position.

NOTE: The factory default setting of the soap dispense volume is 2 ml. The factory default setting of the soap bottle size is 1600 ml.

NOTE: The dispenser comes equipped with a 1600 ml reservoir, and the soap counter is set to the 1600 ml position. If an 800 ml reservoir is used, move the soap counter to the 800 ml position.

- Lift the rubber cover to access the control switches.
- Set the position of the two volume switches for the desired volume of soap dispensed. Refer to the settings shown above.
- Verify that the soap counter switch is set to the correct position for your reservoir size.

- Close the rubber cover.
- Refer to the chart below for the approximate number of dispenses available based on the volume setting and a full 800 ml or 1600 ml reservoir.

Setting	Soap Volume Dispensed	1600 ml Bottle Soap Count	800 ml Bottle Soap Count
A	0.8 ml	1700	850
B	1.2 ml	1133	567
C	1.6 ml	850	425
D	2.0 ml	680	340

11. Self-Learning Sensor Range Adjustment

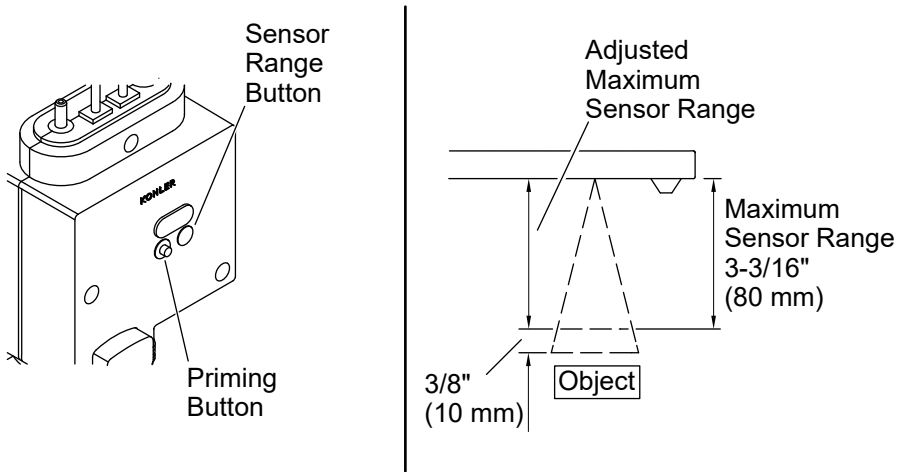

NOTE: The default sensor distance is 2-3/4" +/- 1/4" (70 mm +/- 6 mm).

- Press the light grey sensor range button on the soap dispenser control unit for at least 2 seconds to start the sensor self-learning mode and adjust the sensor range.
- The LED at the base of the spout will emit red light for 2 seconds indicating that the sensor self-learning mode has started.
- The sensor range will initially extend out to a maximum of 3-3/16" (80 mm).
 - If no object is detected, the sensor range will adjust to back to the 2-3/4" (70 mm) default sensor range setting.
 - If an object is detected, the maximum sensor range will adjust by creating a 3/8" (10 mm) space between the end of the sensing cone and the detected object.
- During the sensor range self-learning operation, the LED will blink red twice every 1 second for a total of 10 seconds. This indicates that the sensor self-learning mode is in process.
- The LED will emit a blue light for 2 seconds to indicate that the self-learning sensor range adjustment period has been completed and was successful. The LED will emit a red light for 2 seconds if the self-learning mode has failed. The red LED light will remain constantly on if the detected object is too near to the sensor lens. This condition can be corrected by removing the object and restarting the sensor self-learning mode.

Spout LED Indicators

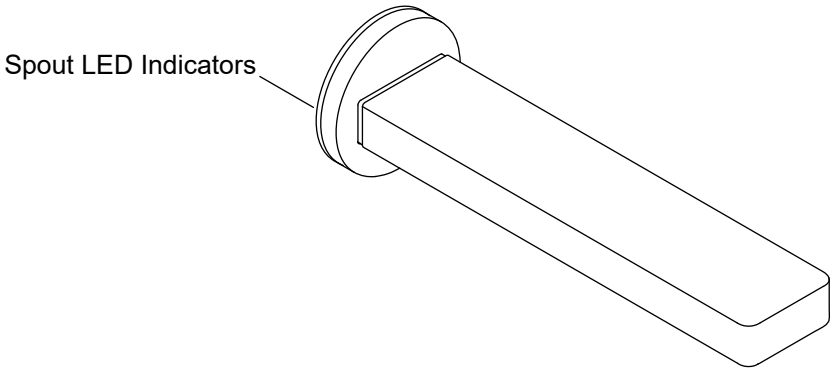

Low Battery - Flashing BLUE

The base of the soap dispenser will flash BLUE every 6 seconds when the voltage is lower than 4.8 V. The soap dispenser will continue to dispense soap.

The base of the soap dispenser will flash (twice) BLUE every 6 seconds when the voltage is lower than 4.5 V. The soap dispenser will not work. Replace the batteries.

Low Soap - Flashing RED

The base of the soap dispenser will flash RED every 6 seconds when the soap is running low. The soap dispenser will continue to dispense soap.

The base of the soap dispenser will flash (twice) RED every 6 seconds when the soap is empty. The soap dispenser will not dispense soap. Refill the soap reservoir and reprime the dispenser.

Maintenance - Re-establish Priming

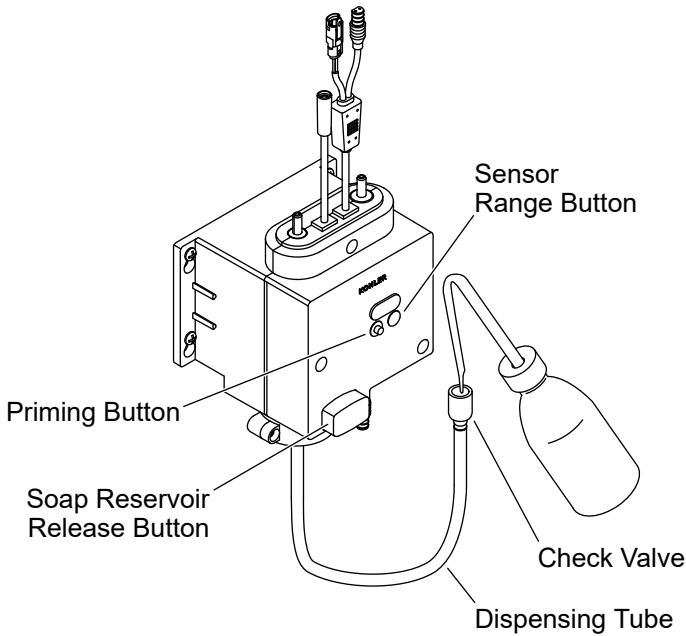

NOTE: The pump gear cavity will dry up and prime will be lost if the unit is activated and the inlet is only sucking air (empty soap bottle). The following steps will re-establish priming.

- Press the soap reservoir release button to disengage the soap reservoir from the control unit assembly.
- Clean the check valve from the dispensing tube with warm water.
- Fill the dispensing tube with water or soap using a small bottle with a nozzle.
- Attach the full bottle of soap to the control unit assembly.
- Press and hold the priming button for approximately 10 seconds after each soap refill until the soap streams out from the spout nozzle.

Care and Cleaning

Do not use any abrasive or harsh cleaners to clean the spout.

For best results, keep the following in mind when caring for your KOHLER product:

Always test your cleaning solution on an inconspicuous area before applying to the entire surface. Visit kohler.com/clean for KOHLER brand faucet cleaner products.

Wipe surfaces clean and rinse completely with water immediately after applying cleaner. Rinse and dry any overspray that lands on nearby surfaces.

Do not allow cleaners to soak on surfaces.

Use a soft, dampened sponge or cloth. Never use an abrasive material such as a brush or scouring pad to clean surfaces.

Upon cleaning other areas of the restroom be sure that the sensor lenses are protected from other cleaning chemicals/solvents to prevent potential damages to the sensor and/or electronics.

It is recommended to flush the system with warm water every 2 to 3 months.

- Remove and clean the nozzle foaming assembly with warm water.
- Remove and clean the check valve from the dispensing tube in the soap reservoir with warm water.
- Clean the soap reservoir then fill with minimal clean warm water. Reattach the soap reservoir to the control box. Press and hold the yellow priming button until all residual water is pushed through the soap dispenser.
- Empty the soap reservoir.
- Refill the soap reservoir with the appropriate foaming hand soap. Press and hold the yellow priming button until any residual water is pushed through the pump and soap is dispensed.

Troubleshooting

This troubleshooting guide is for general aid only. For warranty service, contact your dealer, wholesale distributor, or call 1-800-4KOHLER.

Symptoms	Probable Cause	Recommended Action
1. A red LED light flashes at the base of the soap dispenser once every 6 seconds.	A. The soap is running low (70% of the soap has been used after priming).	A. Refill the soap reservoir with appropriate foaming hand soap. Prime the soap dispenser to restart the soap dispenser.
2. A red LED light flashes at the base of the soap dispenser twice every 6 seconds and the soap dispenser has stopped dispensing soap.	A. The soap is out or very low (90% of the soap has been used after priming).	A. Refill the soap reservoir with appropriate foaming hand soap. Prime the soap dispenser to restart the soap dispenser.
3. A blue LED light flashes at the base of the soap dispenser once every 6 seconds.	A. The batteries are running low (lower than 4.8 V).	A. Replace the batteries. Refill the soap reservoir with appropriate foaming hand soap. Prime the soap dispenser to restart the soap dispenser.

Symptoms	Probable Cause	Recommended Action
<p>4. A blue LED light flashes at the base of the soap dispenser twice every 6 seconds and the soap dispenser has stopped dispensing soap.</p>	<p>A. The batteries are out of power (lower than 4.5 V).</p>	<p>A. Replace the batteries. Refill the soap reservoir with appropriate foaming hand soap. Prime the soap dispenser to restart the soap dispenser.</p>
<p>5. No soap dispenses.</p>	<p>A. The sensor lens is dirty. B. The sensor assembly cable is disconnected. C. The tube (soap and air) is disconnected. D. No power supply or wrong connection. E. The soap pump is not primed after refilling. F. The dispensing tube/check valve is blocked. G. Object is within sensing range. H. The nozzle/foaming device is plugged. I. Motor does not actuate.</p>	<p>A. Wipe the sensor lens with a clean, dry, soft cloth. B. Reconnect the sensor assembly cable. C. Reconnect the tube to the control box. D. Check the power supply connection. E. Press the yellow priming button located on the control unit after each soap refill until the soap streams out of the spout nozzle (approximately 10 seconds). F. Clean the dispensing tube/check valve with warm water. G. Remove the object from the sensor range and wait 20 seconds before activating the soap dispenser. H. Clean the nozzle and the check valve. Re-establish priming. I. Check the power supply connections. Replace the battery. Order and install a new control unit assembly.</p>

Symptoms	Probable Cause	Recommended Action
6. The volume of soap dispensed is small or nonexistent.	<p>A. The nozzle is clogged.</p> <p>B. The check valve is clogged.</p> <p>C. The soap pump is not working correctly.</p>	<p>A. Remove the soap nozzle and foaming assembly. Clean with warm water.</p> <p>B. Remove the check valve from dispensing tube. Clean with warm water.</p> <p>C. Order and install a new control unit assembly.</p>
7. Only air bubbles are dispensing.	<p>A. The soap pump outlet is clogged.</p> <p>B. The soap pump is leaking.</p> <p>C. The soap pump lost priming.</p>	<p>A. Remove the soap pump tubing. Clean the soap pump outlet with warm water.</p> <p>B. Order and install a new control unit assembly.</p> <p>C. Refer to the re-establish priming steps in the "Prepare the Soap Dispenser" section.</p>
8. No foam is dispensing. Only liquid soap is dispensing.	<p>A. The air pump is disconnected.</p> <p>B. The air pump/ tube is clogged.</p> <p>C. The air pump is not working.</p>	<p>A. Check the air pump connection and reconnect the tube to the control box.</p> <p>B. Remove the air pump tubing. Clean the air pump outlet with warm water.</p> <p>C. Order and install a new control unit assembly.</p>
9. Pump prime is lost or air is in the pump/ tubing.	<p>A. The soap reservoir was not filled and/or the yellow prime button was not pressed.</p>	<p>A. Re-establish pump prime per the care and cleaning instructions.</p>

Compliance

This device complies with Part 15 of the FCC Rules. Operation is subject to the following two conditions: (1) this device may not cause harmful interference, and (2)

this device must accept any interference received, including interference that may cause undesired operation.

Changes or modifications not expressly approved by the party responsible for compliance could void the user's authority to operate the equipment.

This equipment has been tested and found to comply with the limits for a Class B digital device, pursuant to Part 15 of the FCC Rules. These limits are designed to provide reasonable protection against harmful interference in a residential installation. This equipment generates, uses, and can radiate radio frequency energy and, if not installed and used in accordance with the instructions, may cause harmful interference to radio communications. However, there is no guarantee that interference will not occur in a particular installation. If this equipment does cause harmful interference to radio or television reception, which can be determined by turning the equipment off and on, the user is encouraged to try to correct the interference by one of the following measures:

- Reorient or relocate the receiving antenna.
- Increase the separation between the equipment and receiver.
- Connect the equipment into an outlet on a circuit different from that to which the receiver is connected.
- Consult the dealer or an experienced radio/TV technician for help.

This Class B digital apparatus complies with Canadian ICES-003.