



Culligan®

*Culligan
Water Tower™
Drinking Water
System
Owners
Guide*





NOTICE: This system is intended for use on potable water supplies or disinfected water containing cysts. Do not use where water is microbiologically unsafe or with water of unknown quality. If bacterial contamination is present, a recognized method of water disinfection is required.

Check with your public works department for applicable local plumbing and sanitation codes. Follow your local codes if they differ from the standards used in this manual.

Operational, maintenance and replacement requirements are essential for this product to perform properly. The Culligan Water Tower™ contains replaceable particulate and activated carbon filters. It also includes a replaceable reverse osmosis membrane filter which is critical for the effective reduction of Total Dissolved Solids. The filtered water should be tested periodically to verify that the system is performing properly.

Culligan International Company
One Culligan Parkway
Northbrook, Illinois USA 60062-6209
847/205-6000
<http://www.culligan.com>



Table of Contents

Safety/Warnings	i
System Specifications	2
Introduction	
About Your System	3
System Component Description	3
Application Guidelines	4
Certified Performance	5
Installation	6
Servicing Your System	7
Cartridge Replacement, Cleaning and Sanitizing Procedure	8
Troubleshooting Guide	14
Parts List	16
Service Log	17
Warranty	18



System Specifications

System Flow Sequences Sediment Filter, Activated Carbon Filter,
Reverse Osmosis Membrane, Storage Tank,
Polishing Filter, Dispensing Faucet.

Sediment Filter Spun Polypropylene Type

Carbon Filter Activated Carbon Block

Reverse Osmosis Membrane Thin Film Composite Type

System Daily Production Rate
to Pressurized Storage Tank¹ 11 gpd

Product Production Rate without
Storage Tank to Atmosphere² 35 gpd

Ratio of Product to Flush Flow³
Soft Water Applications 1:1
Hard Water Applications 1:3 - 1:5

Polishing Filter Activated Carbon Block

Dispensing Faucet Culligan[®] Smartap[®] Rotary Operation,
Stainless Steel and Resin Flow Passages, with
Built-in Siphon Break and Quality Monitor

Color Options Polished Chrome, Satin Chrome, White, Black,
Black/Chrome, Almond

Storage Capacity 3 gallons (max.)
2.4 gallons (nom.)

Dimensions

Filter Assembly 15.5"W x 6"D x 15"H
Storage Tank 11" Diameter x 15.5"H

1 Rating at 50 psi, 77°F, 500 mg/L TDS influent.

2 This is a factory specification for membrane production. Actual production rate and TDS reduction will depend on temperature, water pressure, TDS level, membrane variation and usage pattern.

3 May vary with pressure. See Technical Manual for all hard water applications and applications where TDS exceeds 1000 mg/L (ppm).



Introduction

Thank you for choosing a Culligan Water Tower™ drinking water system. Your new system is designed to bring you years of healthful, deliciously crystal-clear Culligan® water. With its special faucet installed on your sink, it's like getting bottled water straight from your kitchen tap.

With the Culligan Water Tower drinking water system, you'll get a continuous supply of clear, refreshing water for drinking and cooking. But Culligan improves a lot more than just water. Crystal clear Culligan water is ideal for:

- coffee
- ice cubes
- juice
- everything you make with water
- recipes
- soup
- pets
- pasta
- houseplants
- drink mixes
- tea
- steam irons
- baby formula

With three separate water treatment technologies and its unique space-saving design, the Culligan Water Tower drinking water system is the most advanced drinking water system available from Culligan today.

About Your System

The reverse osmosis method of water treatment has long been regarded as one of the most efficient and effective ways to reduce impurities. It's the technology we've used to build your new Culligan Water Tower drinking water system. In addition, we've incorporated activated carbon and fine particle filtration to bring you one of the most effective systems available today.

Culligan Water Tower System Components

Refer to Figure 2, page 6

Sediment Filter

The sediment filter screens out dirt, sand, rust, and other microscopic particles 15 times smaller than a grain of sand.

Activated Carbon Filter

The activated carbon filter gets rid of bad tastes and odors, including chlorine, if present in your untreated water supply.

Reverse Osmosis Membrane Cartridge

The reverse osmosis (RO) membrane squeezes out dissolved substances, including radium, lead, and many others. These substances may not be in your water. See Performance Data Sheet for list of substances and removal percentages.

Manifold Assembly

The manifold serves as the functional hub of the system, directing and regulating the flow through each of the system's components. It makes the Culligan Water Tower drinking water system extremely space efficient and simplifies filter changes.

Storage Tank

The storage tank holds Culligan® water under pressure for rapid delivery.



Polishing Filter

The Culligan Water Tower™ drinking water system includes a second activated carbon filter in the manifold as added assurance that your water will be crystal clear.

Culligan® Smartap® Water Quality Monitor and Faucet

The special drinking water faucet mounts conveniently on your kitchen sink. A simple twist of the handle is all it takes to enjoy refreshing Culligan drinking water.

Your Culligan Water Tower incorporates a proven performance indicator. The patented Smartap® Water Quality Monitor uses dual probe LOGIC PULSE MEMORY technology to accurately indicate membrane performance. A split-second power pulse compares feed water Total Dissolved Solids (TDS) level with that of the product water. Then, by reversing the polarity of the electronic pulse, the probes are cleaned and kept free of chemical plating.

Electronics from the Culligan Water Tower connected to the Smartap faucet provides feedback on system operation.

Indications appear in a light bar integrated into the faucet body front cover (Figure 1). Power is provided through a nine-volt alkaline battery. To prolong battery life, indicator lights self-extinguish after a few seconds even if water is being dispensed.

- Green means quality Culligan water
- Orange tells you that a service check is necessary
- Yellow means a filter change is required

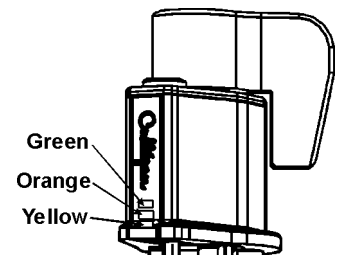

FIG. 1

Application Guidelines

The Culligan Water Tower drinking water system is designed for use on potable water supplies meeting the guidelines outlined in Table 1. The system should be installed on your home's cold water line. The flushing stream should discharge through an approved siphon break as illustrated in Figure 2, page 6. Installation of this system must comply with state and local laws and regulations.



Table 1

Influent Water Characteristics	
Pressure ¹	35-100 psi (242-690 kPa)
Temperature	40-100°F (4-38°C)
Total Dissolved Solids (TDS) ²	0-2000 ppm (0-2000 mg/L)
pH	3.0 - 11.0
Chlorine ³	0-2 ppm (0-2 mg/L)
Chloramine	0-2 ppm (0-2 mg/L)
Turbidity	<1.0 NTU
Silt Density Index (SDI)	<4
Hardness (CaCO ₃)	<350 ppm
Hydrogen Sulfide (H ₂ S)	0.00 ppm
Manganese (Mn)	<0.05 ppm
Iron	0-1 ppm (0-0.1 mg/L)
Bacterial Quality ⁴	Potable

¹ A pressure regulator is recommended for feed water pressures exceeding 80 psig (552 kPa)

² See the Technical Manual for all applications where TDS exceeds 1000 ppm (1000 mg/L) to calculate effective module pressure. A booster pump is strongly recommended.

³ The reverse osmosis membrane filter used in this system may be damaged by chlorine. This system includes activated carbon which protects this element by reducing chlorine. Influent chlorine should not exceed 2 mg/L.

⁴ Do not use with water that is microbiologically unsafe or of unknown quality without adequate disinfection before or after the system.

Certified Performance

System Tested and Certified by NSF International against ANSI/NSF Standard 58 for the reduction of: Barium, Cadmium, Copper, Fluoride, Hexavalent Chromium, Lead, Radium 226/228*, Selenium, Total Dissolved Solids, Trivalent Chromium, Cysts, and Turbidity



The substances removed by this system are not necessarily in your untreated water. See Performance Data Sheet for percentages of contaminant removal.

* Minimum removal based on approved testing methods with Barium as surrogate.



Installation

This Owner's Guide provides visual assembly reference only (Figure 2). Since specialized skills are required in the assembly of the drinking water system, we recommend that you contact your local independently operated Culligan® dealer to complete this installation.

Component Location

Product Water Faucet

Faucet may be located in any convenient location. Make sure underside of location is free of obstruction.

Culligan Water Tower™ Module*

Module may be installed under sink or in any convenient location within 15 feet of source water supply and product water faucet.

Storage Tank

Tank may be placed in any space within 15 feet of faucet, generally under kitchen sink or in adjacent unused cabinet. Tubing length between components should be kept to a minimum, avoiding sharp bends or kinks.

***For installations in Massachusetts, Massachusetts Plumbing Code 248CMR shall be adhered to. Consult your licensed plumber for installation of this system. The use of piercing valves is not permitted in Massachusetts.**

The use of piercing valve is NOT permitted in Massachusetts.

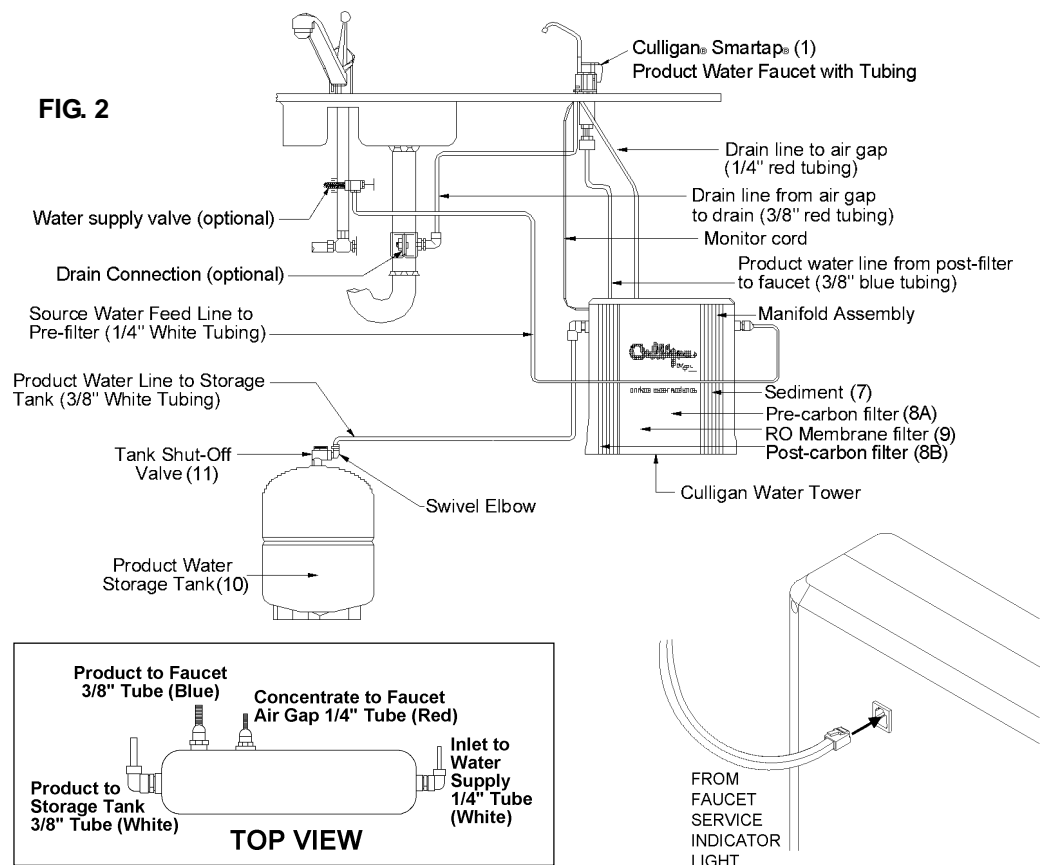



Servicing Your System

Service Schedule

When properly maintained, your Culligan Water Tower™ drinking water system will give you years of dependable service. Use the following as a guide to get the most out of your system. Service frequency may vary depending on your local water conditions. High sediment, chlorine, turbidity or hardness levels may require more frequent service.

At least once per year

Replace:

- Sediment Filter Cartridge (Item 7)
- Activated Pre-Carbon Filter Cartridge (Item 8A)
- Activated Post-Carbon (Polishing) Filter Cartridge (Item 8B)

Check:

- RO Membrane Cartridge (Item 9)
 - TDS Reduction Performance
 - Flow Rates - Concentrate & Product
- Flow Control (Item 6)

Clean and Sanitize the System

Use the convenient chart inside the back cover of this booklet to keep track of your system's maintenance.

Equipment Needed

- Safety glasses
- Rubber gloves, sanitary
- Wash cloth, clean and lint-free
- Liquid dish soap
- Household bleach - unscented only (5-1/4% sodium hypochlorite)
- Plastic storage bag
- Manual air pump
- Plastic bucket
- Plastic bowl
- Silicone lubricant, FDA approved

Have all components and supplies on-hand and ready before beginning procedure.

A clean work area and equipment are essential to properly clean and/or sanitize the system (i.e., clean hands, tools, work surface and containers).

Cartridge Replacement

Culligan recommends that you have your Culligan Water Tower drinking water system serviced by your local Culligan Man™. You can rely on his or her experience and expertise to keep your system in top operating condition.



If you wish to service your system, the filters are available from your Culligan dealer. See the Parts List at the end of this section for replacement numbers.

Cartridge Conditioning

The activated carbon, reverse osmosis, and polishing filter cartridges must be conditioned as follows prior to installation into the Culligan Water Tower™ drinking water system. Your Culligan Man™ can do these important procedures at the time of purchase.

Activated Pre-Carbon Filter Cartridge - 2 gallon flush to remove carbon dust

RO Membrane Cartridge - 6 hour flush to remove preservative solution

Activated Post-Carbon (Polishing) Filter Cartridge - 2 gallon flush to remove carbon dust

Tubing Connectors

The Culligan Water Tower drinking water system features easy-to-use push-in tubing connectors (Figure 3). Fittings consist of two parts: a body and a colored collet. Collet color corresponds to tubing color to be used at that connection (Figure 3A).

1. To install a tube, lubricate the tubing end with water (only) and push it through collet until it seats firmly at bottom of fitting (Figure 3B). You should feel the tubing pass the O-rings. Cut ends must be square. Be sure the tubing is smooth and free of abrasions, otherwise a leak may result. Cut tubing only with a new razor blade.
2. To remove a tube, push and hold the collet against the fitting body and pull the tube from the fitting. (Figure 3C).

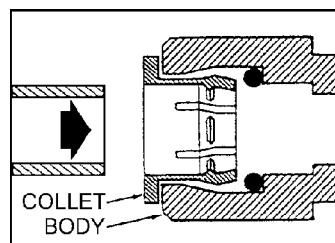

FIG. 3A

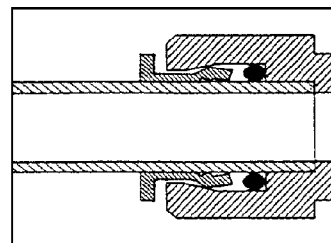

FIG. 3B

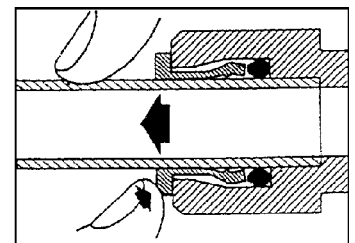

FIG. 3C

Cartridge Replacement, Cleaning and Sanitizing Procedure

1. Mix a mild cleaning solution of dish soap and clean potable water in plastic bowl.
2. Empty storage tank and relieve system pressure. Verify tank valve is open. Close feed water supply valve and open product water faucet.

Note: Additional point-of-use devices (i.e. icemakers) may use filters along their supply line. Remove any filter or treatment device installed between module and delivery device before proceeding.

Icemaker: Transfer ice cubes from bin/tray to clean freezer container for storage until procedure is done.



3. Check product water storage tank air pre-charge using low-pressure gauge (PN 34002024). Air valve is located on tank base. Pre-charge should be 55 kPa (8 psig) with tank empty and tank valve open.

Note: Use hand pump to avoid damaging tank. Verify product water faucet is open before proceeding. Use caution when working with/inside enclosure. Wiring therein connects monitor components. If wires, circuit board, or connections are damaged and/or wetted, monitor will not function.

Item callouts refer to Figure 5 unless otherwise noted.

4. Remove enclosure front panel by pressing in push-in tabs and pull cover back. (Figure 4)

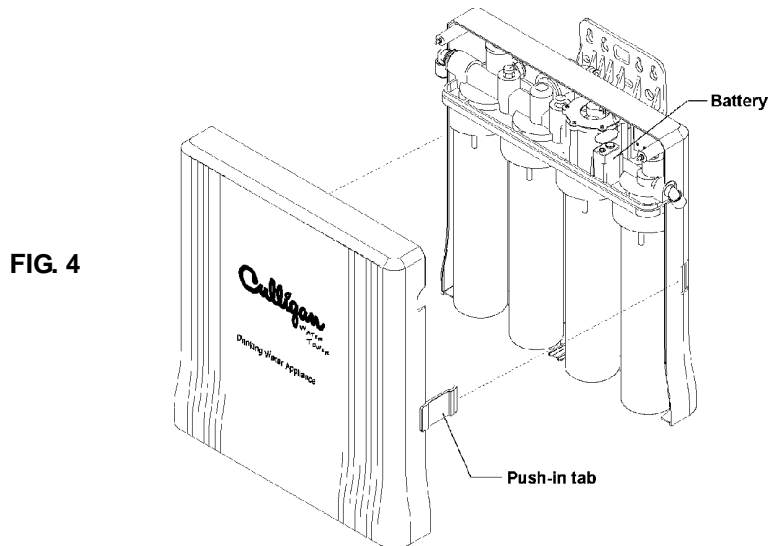

5. Remove each filter housing (Item 30) by turning it counter-clockwise. Remove each filter cartridge (Figure 5).
 - a. Discard sediment (Item 7) and carbon (Item 8) cartridges
 - b. Examine membrane (Item 9). If it is performing satisfactorily, proceed to Step 6. If it is depleted or fouled, discard it and proceed to Step 8.

Note: Wear gloves whenever cleaning/sanitizing system or handling new filter/membrane cartridges.

6. Clean membrane outer wrap with washcloth and cleaning solution. Do not immerse membrane in solution. Do not scrub wrap with abrasive cleaners. Rinse membrane well with clean potable water.
7. Place membrane into clean plastic bag, close bag.
8. Remove filter housing O-rings and wash them with cleaning solution. Rinse them well with clean potable water. Inspect them for damage such as nicks or scratches. Replace damaged O-rings.



FIG. 5

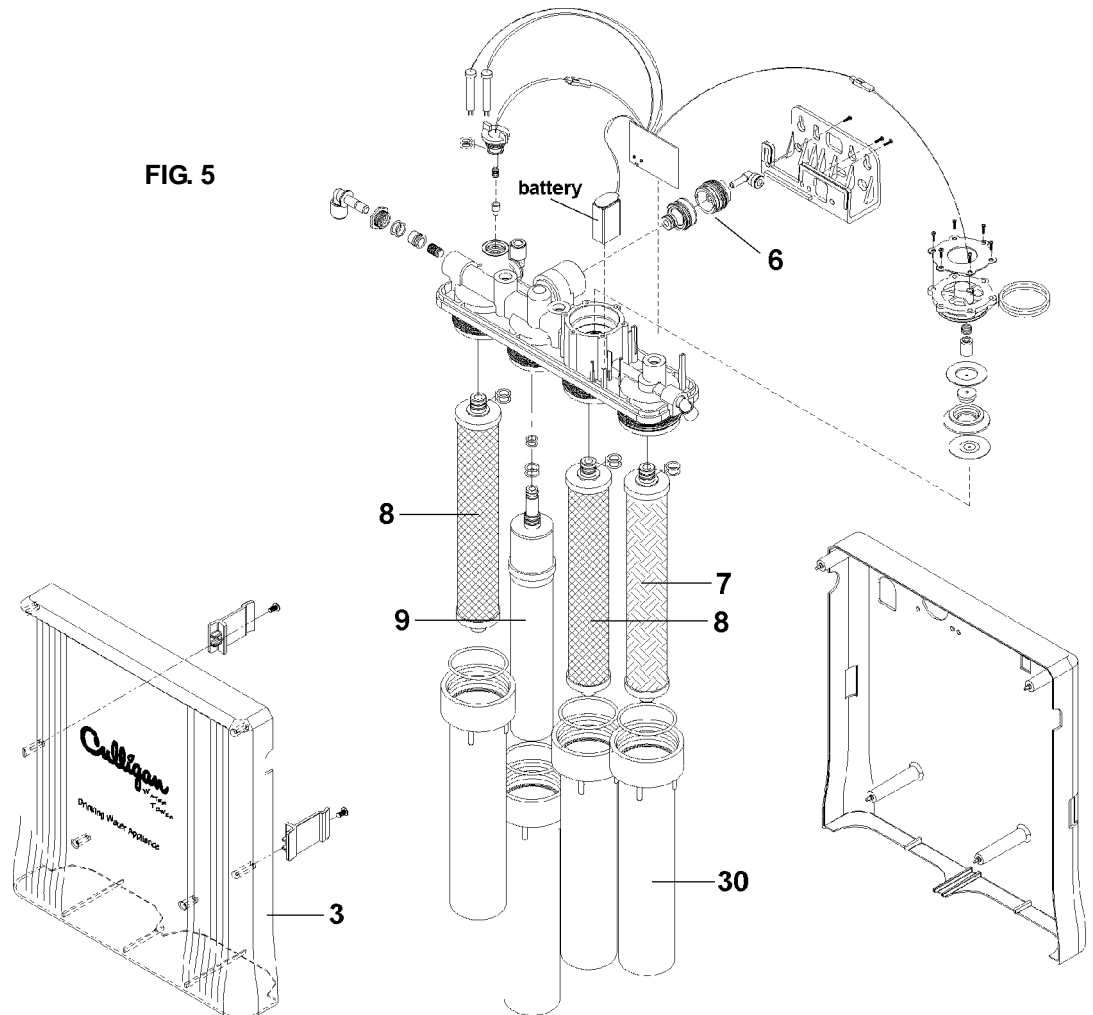

9. Clean filter housings/manifold, inside and outside, with washcloth and cleaning solution. Do not use abrasive materials.

10. Rinse housings/manifold with clean potable water.

11. Inspect filter housing O-ring groove and manifold O-ring surface for damage such as nicks or scratches. Replace if damaged.

12. Place a small amount of O-ring lubricant on surface of filter housing O-ring. Install O-ring into housing.

TO SANITIZE THE SYSTEM: Complete Steps 13-33.

TO INSTALL FILTERS: Complete Steps 20-33.



⚠ CAUTION: Wear safety glasses while performing this procedure.

⚠ CAUTION: Read “WARNINGS” information on bleach container before using contents. Handle sanitizing solution carefully. Avoid contact with unprotected areas.

13. Mix sanitizing solution of 1.5 ml (1/3 teaspoon) of household bleach and 3.8 L (1 gallon) of clean, potable water in the bucket. Mix solution well.

Note: Excessive concentrations of bleach (sodium hypochlorite) may damage plastic and rubber components. Rinse all parts that contact bleach thoroughly with clean potable water.

14. Add 236 ml (one cup or 8 oz.) of sanitizing solution to each filter housing and install them onto the manifold (do not install filters or membrane at this time). Tighten each filter housing by hand only.

Note: Tighten filter housings by hand only. Do not use tools as they will over-tighten and damage housings.

15. Slowly open source water supply valve.
16. Close product water faucet as soon as water begins to flow from spout.
17. Wait 5 minutes, then close source water supply valve.
18. Wait 25 minutes, then open product water faucet. Let water flow to drain until system is drained (flow stops), then close faucet.

Note: Remove filter housings only after water flow stops.

19. Remove filter housings and dispose of water. Rinse housings/manifold thoroughly with clean, potable water.

Note: Do not remove protective plastic bag from replacement filter and membrane cartridges.

Note: For optimum monitor performance, the monitor must be re-set and the battery replaced each time system is sanitized. However, a technician may wait until indicator lights fail to illuminate to replace battery.

20. Hold cartridge by its protective plastic bag and open protective bag to expose cartridge cap and O-rings.



21. Install cartridges. (Refer to Figure 5 for location of each cartridge).
 - a. Hold cartridge by its protective plastic bag
 - b. Insert cartridge into manifold turning it 1/2 turn as it enters port. Slide bag from cartridge and discard.
 - c. Install filter housing (Item 30) as each cartridge is inserted. Make sure housing o-ring is properly lubricated.

Note: Tighten filter housings by hand only. Do not use tools as they will over-tighten and damage housings. Take care not to cut or pinch the O-rings.

22. Turn feed water valve slowly to open position.

23. Confirm system is producing water. Unit will be sending rinse water to drain. Check for leaks.

Note: Monitor must be re-set each time the system is serviced to ensure accurate monitor performance.

TO RE-SET MONITOR or TO CHANGE BATTERY: Perform Steps 24-27
Refer to Figure 6 for component location.

Use caution when working inside enclosure. Wiring therein connects monitor components. If wires, circuit board, or connections are damaged and/or wetted, monitor will not function.

Connect battery to monitor after system has been in production mode for at least 5 minutes. This ensures sensing switch is in proper position to record data.

24. Disconnect battery. The connection is a snap type connector.

25. Remove battery by sliding it out of its holder.

FIG. 6

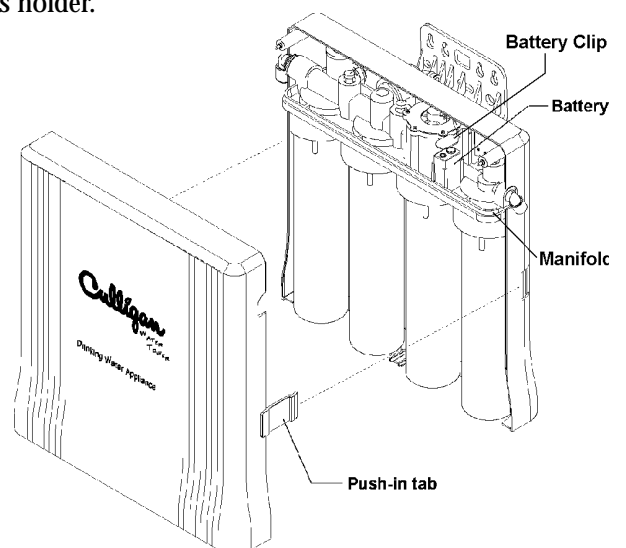



Note: Replace battery with a new alkaline 9-volt battery (PN 31300001)

26. Carefully slide battery into its holder.
27. Connect battery by pressing clip onto battery terminals.
28. Test monitor connection by activating monitor. Open product water faucet. If an indicator light illuminates, connection is good.

Note: Close faucet immediately after light illuminates. Test confirms battery connection, not water quality.

29. Install enclosure front panel (Item 3):
 - a. Place panel in position, aligning push-in tabs with openings. Verify circuit board wiring is not pinched between panels.
 - b. Press panel inward until push-in tabs engage, securing the panel.
 - c. Check for leaks.
30. Open product water faucet. Let water flow until all air has been expelled from the system.
31. Close product water faucet. Wait 30 minutes, check connections for leaks, and correct if necessary.

Icemaker/Extra point of use: Check lines for leaks.

32. Allow storage tank to fill overnight.

DO NOT USE FIRST FULL STORAGE TANK OF WATER

33. Discard (to drain) first full tank of water by opening product water faucet until water flow stops, then close faucet. This flushes sanitizing solution from system.

Icemaker: Let tray/bin fill with ice cubes. Discard all ice cubes to drain. This flushes sanitizing solution from lines in icemaker. Replace delivery device filter (if applicable).

Note: System is ready to use. Should there be any aftertaste or odor, drain storage tank and repeat Steps 32 and 33.



Troubleshooting Guide

Water Volume and Quality		
Symptom	Condition	Action
No product water	Water supply is turned OFF	Turn water ON
Not enough product water	Low water pressure	Check source water line pressure
	Inlet water supply valve is blocked	Clear restriction
	Storage tank valve is closed	Open storage tank valve
	Storage tank is depleted	Increase product water storage capacity and/or install membrane with higher output rating
	Clogged pre-filter cartridge(s)	Replace pre-filter cartridge(s)
	Storage tank air pressure charge is low	Empty water from storage tank (product water faucet must remain open while adjusting pressure) and adjust pressure to 55 kPa (8 psig)
System does not shut off	Shut-off valve is not closing	Contact your Culligan® Dealer
No drain water	Clogged flow control	Replace flow control (Item 6) in parts list and contact your Culligan® Dealer
Water has offensive taste and/or odor	Carbon post-filter is depleted	Drain storage tank, sanitize system and replace carbon post-filter cartridge
	Membrane depleted or fouled	Smartap® Quality Monitor reads yellow, or if TDS test is unsatisfactory, drain storage tank, sanitize system and replace membrane
	Sanitizer not flushed out	Drain storage tank and let it refill overnight



Leakage		
Symptom	Probable Cause	Solution
Leak at fitting	Tubing not pushed completely into fitting	Push tube into fitting past O-ring seal
	Defective tube	Cut damaged area from tube or replace tube
	Tubing makes too tight a bend near fitting	Run the tubing to reduce the bend
Leak at filter housings	O-ring has not seated properly	Remove O-ring and inspect O-ring groove for debris. Clean groove, lube and reseal O-ring
	O-ring has nicks or scratches	Replace O-ring
Leak from air gap in faucet	Restricted drain tube	Clear restriction
	Tubing from air gap to drain is routed incorrectly	Re-route tubing so tubing runs vertically with no sharp bends or loops

Smartap® Quality Monitor Status Indications and Common Solutions

Indication	Condition	Action
Green Light	System operating normally	None
Orange Light (appears with green or yellow light)	Shut-off valve is not closing	Call your Culligan® dealer
Yellow Light	Membrane exhausted	Replace membrane
No Monitor Lights	Light Assembly is not connected	Plug connector into phone jack
	Battery voltage low	Replace battery
	Battery is not connected	Connect battery



Parts List

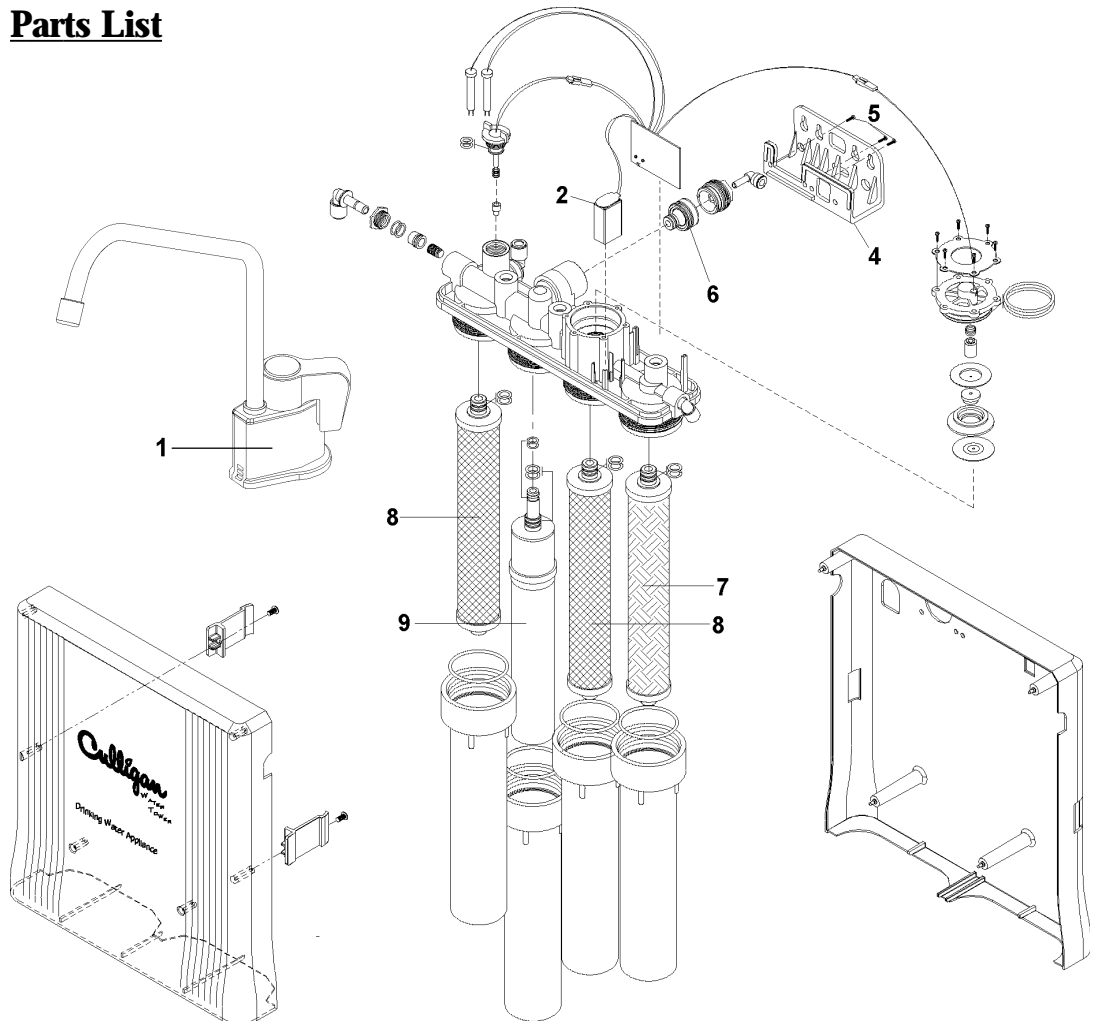

Item	Description	Part No.
1	Culligan Faucet, Chrome body/spout	11403430
	Culligan Faucet, White body/spout	11403431
	Culligan Faucet, Almond body/spout	11403433
	Culligan Faucet, Black body/spout	11403434
	Culligan Faucet, Satin body/spout	11403436
	Culligan Faucet, Black body/Polished spout	11403439
2	Battery, 9-volt alkaline	31300001
4	Bracket, Mounting	21100101
5	Screw, Mounting Bracket	32701002
6	Flow Control, Green Tape	40600037
7	Cartridge, Sediment Culligan®	01013028
8	Cartridge, Carbon Culligan®	01013029
9	Cartridge, RO Membrane - Green Casing - Purple Tape Culligan®	41402004
10	Tank, Product Water Storage - White	34500003
11	Valve, Shut-off w/O-ring	33503601
12	Elbow, 3/8" Stem w/white collet Gauge Air Pressure	33503504 34002024

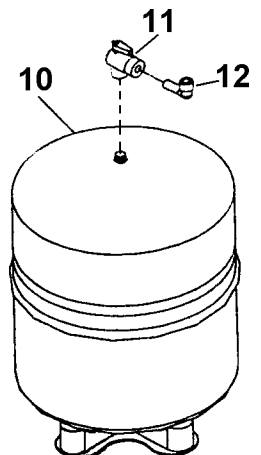

Part Numbers in bold italics are Valencia, CA Part Numbers



Culligan Water Tower™ Service Log

Model _____ Serial No. _____

Date Installed _____

For Service Call Culligan at: () — _____

Date Serviced	Cartridge(s) Changed				Sanitized
	Sediment Filter	Activated Pre-Carbon Filter	RO Membrane	Activated Post-Carbon Filter	



Culligan Lifetime Limited Warranty

CULLIGAN WATER TOWER™ CWT-35 MODEL SERIES

You have just purchased one of the finest drinking water systems made. As an expression of our confidence in Culligan International Company products, your drinking water system is warranted to the original end-user, when installed in accordance with Culligan specifications, against defects in material and workmanship from the date of original installation, as follows:

For the LIFETIME of the original end-user

The entire reverse osmosis drinking water appliance, EXCLUDING THE EXPENDABLE FILTER CARTRIDGES AND REVERSE OSMOSIS MEMBRANE FILTER USED IN THIS APPLIANCE.

Pro rata for a period of ONE YEAR

The original Culligan reverse osmosis membrane filter. Culligan will reduce the cost of a replacement Culligan reverse osmosis membrane filter by 1/12th of the then-current manufacturer's suggested retail price for each month remaining in the year period when the defect is found and confirmed by a Culligan dealer.

If a part described above is found defective within the specified period, you should notify your independently operated Culligan dealer and arrange a time during normal business hours for the dealer to inspect the drinking water appliance on your premises. Any part found defective within the terms of this warranty will be repaired or replaced by the dealer. If any part is found defective, Culligan also reserves the right to replace the drinking water appliance with a comparable Culligan drinking water system of equal or greater quality. You pay only freight for repaired or replaced parts from our factory and local dealer charges, including but not limited to labor charges, travel and transportation expenses and handling fees.

Damage caused by accident, fire, flood, freezing, Act of God, misuse, misapplication, neglect, alteration, installation or operation contrary to our printed instructions, or by the use of accessories or components which do not meet Culligan specifications, is not covered by this warranty.

ALL IMPLIED WARRANTIES, INCLUDING WITHOUT LIMITATION WARRANTIES OF MERCHANTABILITY AND FITNESS FOR PARTICULAR PURPOSE, ARE LIMITED IN DURATION TO THE PERIOD SPECIFIED ABOVE FOR THE PARTS DESCRIBED IN THIS LIMITED WARRANTY. As a manufacturer, we do not know the characteristics of your water supply. The quality of water supplies may vary seasonally or over a period of time. Your water usage rate may vary as well. Water characteristics can also change if your drinking water appliance is moved to a new location. For these reasons, we assume no liability for the determination of the proper equipment necessary to meet your requirements, and we do not authorize others to assume such obligations for us. Further, we assume no liability and extend no warranties, express or implied, for the use of this product with a non-potable water source or a water source which does not meet the conditions for use described in the Owner's Guide and Performance Data Sheet. CULLIGAN'S OBLIGATIONS UNDER THIS WARRANTY ARE LIMITED TO THE REPAIR OR REPLACEMENT OF THE FAILED PARTS OF THE DRINKING WATER APPLIANCE, AND WE ASSUME NO LIABILITY WHATSOEVER FOR DIRECT, INDIRECT, INCIDENTAL, CONSEQUENTIAL, SPECIAL, GENERAL, OR OTHER DAMAGES, WHETHER FROM CORROSION OR OTHER CAUSES.

Some states do not allow limitations on how long an implied warranty lasts, so the above limitation may not apply to you. Similarly, some states do not allow the exclusion of incidental or consequential damages, so the above limitation or exclusion may not apply to you. This warranty gives you specific legal rights, and you may also have other rights which vary from state to state. Consult your telephone directory for your local independently operated Culligan dealer, or write Culligan International Company for warranty and service information.

**CULLIGAN INTERNATIONAL COMPANY
One Culligan Parkway
Northbrook, Illinois 60062**

Materials & description: 8-1/2 x 11, 20 page book, saddle stitched, three hole punched - Prints black ink on 50# offset white

LET	CHANGE	BY	APRVD	DATE
A	DCO 1254	TPD	BL	8/21/00

This page contains materials and DCO information. IT DOES NOT PRINT AS PART OF THE DOCUMENT!