



MAXX ICE

MCR3UHC / MCR3U-OHC INSTRUCTION MANUAL

Indoor/Outdoor Refrigerator



MCR3UHC INDOOR



MCR3U-OHC OUTDOOR



English

PLEASE READ THESE INSTRUCTIONS CAREFULLY BEFORE USE

Be sure unit is standing upright 24 hours prior to plug-in

011,121



IMPORTANT SAFEGUARDS

Read all instructions before using this appliance. Use this appliance only for its intended purpose as described in this instruction manual. Always exercise basic safety precautions, as described below. After reading the instruction manual, store it in an accessible place where the user(s) of this product can easily find it.

The purpose of these safety precautions is to ensure safe and correct use of the product to minimize risks that could cause serious damage and injury to you or others. The safety precautions are divided into WARNINGS and CAUTIONS. Cases where improper handling of the unit could lead to death or serious injury are listed under the WARNING heading. However, the cases listed under CAUTION could also lead to serious results. To ensure safety, adhere strictly to both types of safety precautions.



MAXX ICE

IMPORTANT SAFEGUARDS

1. All repairs, disassembly and modifications should be performed only by qualified technicians. Attempting to perform these yourself could result in fire, malfunction or injury.
2. Never splash water directly onto the product or wash it with water without unplugging, as a short circuit could result. In a rainy environment, a water-proof covering is recommended.
3. Never put flammable or volatile substances into the unit as explosion and fire could result.
4. Do not damage, modify, excessively bend, strain, twist or bundle the power cord. Also, placing heavy objects on the power cord or binding it could damage the cord, possibly resulting in electrical shock or fire.
5. Use a dedicated wall outlet. Do not use an extension cord or multiple-outlet adaptor as this could result in electrical shock, overheating and fire.
6. Never use flammable spray cans or leave flammable substances near the unit. Sparks from electrical switches could result in explosion or fire. If a combustible gas is present near the appliance, turn off the source of the gas, then open the windows and doors to allow the gas to dissipate. To avoid an explosion, do not pull the plug or switch off the unit.
7. The electrical socket must have good grounding. The ground wire cannot be connected with a gas pipe, heating pipe, water pipe, telephone line or lightning rod. It cannot be replaced with the neutral wire of single-phase power. In addition to the ground wire, an electrical leakage circuit breaker is also required.
8. If installation in a damp location is unavoidable, have an electrician install a ground fault circuit interrupter (GFCI) electrical outlet. If no GFCI is installed, electrical shock could result.
9. Never climb onto the unit. The unit could tip over or fall and cause material damage or personal injury.
10. Disconnect the power cord plug from the wall outlet before moving the unit and make sure that the power cord is not damaged during transport. A damaged power cord could result in electrical shock and/or fire.
11. Never unplug the unit by pulling on the power cord. Always grip the plug firmly and pull straight out from the outlet. Pulling the cord could cause wire breakage, possibly resulting in overheating and fire.
12. Repair or replace any cord that is frayed. Do not use a cord that shows cracks or abrasions along its length.
13. Do not use electrical appliances inside the food storage compartments, unless they are of the type recommended by the manufacturer.
14. Keep ventilation openings, in the appliance enclosure or in the built-in structure, clear of obstruction.
15. Do not use mechanical devices or other means to accelerate the defrosting process, other than those recommended by the manufacturer.
16. Do not damage the refrigerant circuit.



MAXX ICE

1. This unit must be properly installed in accordance with the installation instructions before it is used. See grounding instructions in the Installation section.
2. This model can either be built-in or free-standing. Built-in units vent at the bottom front and airflow at the front of this vent must be unimpeded.
3. Install the unit in a location where the floor is sturdy enough to support the load of the unit. If the floor is not sturdy enough or installation is incorrectly performed, the unit could tip over and cause personal injury. If the unit is placed on a stand, the front surface must be 3" or more back from the edge of the stand in order to avoid accidental tipping of the appliance during normal usage.
4. Never place heavy objects or items containing water on top of the unit. Objects could fall and cause injury and spilled water could cause the deterioration of the insulation of electrical components and result in electrical shock.
5. Disconnect the unit if it is behaving abnormally, and do not reconnect until the situation is corrected.
6. Pull out the plug before doing any maintenance on the unit to avoid electric shock.
7. Never pull out plug when hands are wet!
8. This unit is not intended for the storage of medicines or chemical reagents.
9. Keep packing materials away from children.
10. Condenser water from evaporator drains into a hole in the floor of the storage compartment and is channeled into a drain pan located at the back of the unit on the compressor. Heat transferred from the compressor evaporates any water that has collected in the pan. Be sure the drain hole in the floor of the unit is clear and unobstructed.
11. During long absences, remove the unit's contents, unplug the unit, clean it and leave the door open slightly to avoid possible formation of condensation, mold or odors. Use a cover to protect the unit and prolong its lifespan.
12. Leave disassembly and disposal of the unit to qualified experts.

SAVE THESE INSTRUCTIONS! DANGER!

Avoid the risk of child entrapment. If product is not in use, remove the door so that small children cannot get trapped inside.

This appliance is intended to be used in household and similar applications such as

- **staff kitchen areas in shops, offices and other working environments;**
- **farm houses and by clients in hotels, motels and other residential type environments;**
- **bed and breakfast type environments;**
- **catering and similar non-retail applications.**



MAXX ICE

TECHNICAL SPECIFICATIONS

Model Number:	MCR3UHC / MCR3U-OHC
Description:	Indoor / Outdoor Refrigerator
Electrical Input:	115VAC ~ 60Hz
Current Rating:	1.1A
Unit Dimensions:	14 $\frac{5}{8}$ "W x 24 $\frac{3}{8}$ "D x 33 $\frac{1}{2}$ "H 370mmWx620mmDx850mmH
Unit Weight:	61lbs/28kg
Ambient Temperature Range:	50°F - 100°F / 10°C - 38°C (MCR3UHC) 25°F - 100°F / -4°C - 38°C (MCR3U-OHC)
Compartment Temperature Range:	35°F - 50°F / 2°C - 10°C

Energy-Saving Tips

- Do not place the unit next to a heating vent, a range or in direct sunlight.
- Keep the door closed as much as possible, especially in hot, humid weather.
- Cover foods to reduce moisture buildup inside the appliance.

LOCATIONS OF PARTS

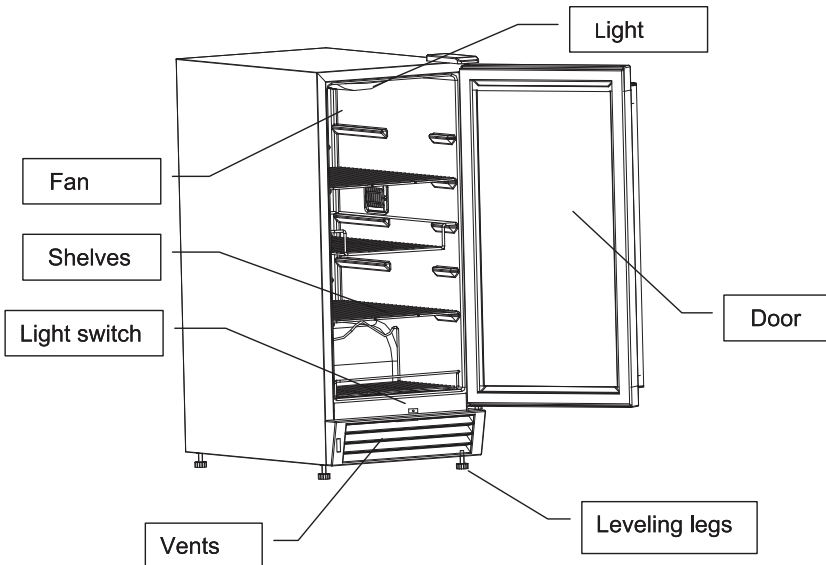



INSTALLATION

Remove the exterior and interior packaging. Use a soft dry cloth to wipe down the outside of the refrigerator thoroughly. Use a clean cloth dampened with lukewarm water to wipe down the inside of the refrigerator.

Air must circulate freely in front of the refrigerator. Avoid placing the appliance near any source of heat or moisture, or in direct sunlight. Direct sunlight may affect the finish, and nearby heat sources will cause higher electrical consumption.

The Refrigerator is designed to be either free-standing or built-in. It has motorized fans at the back of the unit that direct compressor-generated heat away from the compressor and through the front of the unit, keeping the front vents unobstructed. If the unit is built-in, allow minimum clearances of 1/4" at the sides, 1/2" at the back and 1" at the top.



INSTALLATION

Electrical Connection

Important! For your personal safety, this appliance must be properly grounded. In the event of an electrical short circuit, grounding reduces the risk of shock by providing an escape wire for the electric current. This appliance is equipped with a cord having a grounding wire with a grounding plug. The plug must be inserted into an outlet that is properly grounded and installed. The ground wire cannot be connected to a gas pipe, heating pipe, water pipe, telephone line or lightning rod. It cannot be replaced with the neutral wire of single-phase power. In addition to the ground wire, an electrical leakage circuit breaker is also required. Consult a qualified electrician if you do not completely understand these grounding instructions.

DO NOT UNDER ANY CIRCUMSTANCES CUT OR REMOVE THE THIRD (GROUND) PRONG FROM THE POWER CORD.

If installation in a damp location is unavoidable, have an electrician install a ground fault circuit interrupter (GFCI) electrical outlet. If no GFCI is installed, electrical shock could result.

Do Not Use an Extension Cord

Avoid the use of an extension cord because of potential safety hazards under certain conditions.



OPERATING YOUR REFRIGERATOR

IMPORTANT: Do not plug in the refrigerator for 24 hours after unit is set in place. Failure to do so may result in the unit working improperly. This refrigerator has a rotary temperature control knob (thermostat) inside the unit which is marked with the settings OFF-COLD-COLDEST in order of increasing coldness.

Note: To prevent excessive strain on the compressor, do not leave the unit at the COLDEST setting for more than an hour at a time.

Operating instructions

Turning on the Unit

The refrigerator turns on automatically when it is plugged in. When the air temperature is below 40°F, follow this procedure to stop the compressor:

1. Turn the temperature control knob (thermostat) to the COLD setting.
2. Continuing turning the control knob counter-clockwise to the OFF setting. The compressor will stop working.

NOTES:

- If the ambient temperature is above 40°F, turn the thermostat to the range between COLD and COLDEST to cool foods.
- If the ambient temperature is below 25°F, do not use the unit to store anything.
- If you unplug the refrigerator or the power is cut off accidentally, allow 8 minutes before restarting it or plugging it back in. It will not operate properly in less than 8 minutes.

Temperature Setting

Initially set the thermostat to the midpoint between the COLD and COLDEST settings. The compressor will run continuously for a few hours until the temperature inside the appliance becomes stable. After this, the compressor runs normally (i.e., turns on and off periodically).

When the unit is operated for the first time, it is suggested that you not put food inside until the compressor is running normally.

Adjusting the thermostat clockwise will make the compressor run for a longer time with a shorter compressor stop time, and the temperature inside the appliance will become colder. The setting should be regulated according to ambient conditions and the desired temperature. The compressor will run for a while after each regulation before reaching a steady temperature.



MAXX ICE

OPERATING YOUR REFRIGERATOR

Please note: Cold air falls and warmer air rises, and there will be a small temperature variation from the bottom of the unit to the top. The temperature at the bottom of the unit will always be slightly colder.

Operating the Internal Light

This appliance has an internal light to make it easier for you to see the foods you have stored. When the door is open, the light will be on and when it is closed, the light will be off.

Shelving

The wire racks in your unit are chrome-plated so they will not rust. The unit has 3 adjustable chrome-plated flat wire shelves and a wire basket to hold cans and bottles of beverages such as beer, water and soft drinks.

These racks are removable and reversible. To take out a rack, remove any cans or bottles from the rack and pull it out until it stops. Then lift up the front of the rack and remove it from the unit.



CLEANING & MAINTENANCE

Cleaning the Outside

Unplug your refrigerator. Clean the outside with a cloth dampened in warm soapy water. Dry thoroughly with a soft cloth. To clean the door gasket, use only warm soapy water. Never use harsh cleansers or scouring pads to clean any part of your unit.

Cleaning the Inside

Remove all foods, plus shelves and basket. Wash the shelves and basket in a mild detergent solution and dry with a soft cloth. Wash inside with plain water and baking soda solution (about two tablespoons of baking soda to a quart of water). Then rinse and dry. Do not use cleansers such as soaps, detergents, scouring power or spray cleaners which can cause odors inside the refrigerator.



TROUBLESHOOTING

WARNING:To avoid a hazard due to instability of the appliance , it must be fixed in accordance with the instructions.

Unit does not turn on

Not plugged in.

Fuse blown or circuit breaker tripped.

Noise or vibration

Check that unit is level. If not, adjust leveling legs.

Unit is too warm

Check that door is properly closed and sealed.

Check temperature setting. (To change the temperature setting, follow the steps in the Operating Your Refrigerator section of this manual.)

Check if door has been opened frequently.

If you are certain that the door is not the cause of the problem, contact your authorized service facility immediately.



MAXX ICE

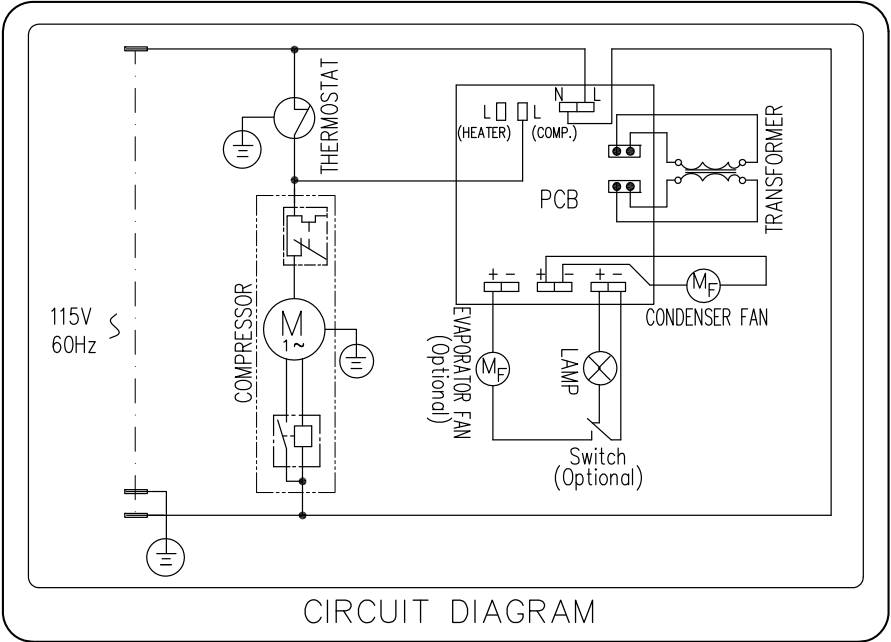



MAXX ICE

PN:1866821407

www.maxxice.com

**3355 Enterprise Ave, Suite #160,
Fort Lauderdale, FL 33331
Phone:(954) 202-7419 · Fax:(954) 202-7337**