



COMMERCIAL BLENDER WITH PADDLE CONTROLS

Operating Instruction Manual



Model	Voltage ~ Hz	Power	Amperage	Plug Type	Volume	Overall Height			Weight
XLB-1000	120V ~ 60Hz	1450W	12.1A	NEMA 5-15P	68oz (2 L)	20" (508mm)			10.4 lbs (4.7 kg)
						Base Dimensions			
						Width	Depth	Height	
						9" (228mm)	10" (254mm)	8-1/2" (216mm)	

BEFORE OPERATING ANY EQUIPMENT, READ AND FAMILIARIZE YOURSELF WITH THESE USE AND SAFETY INSTRUCTIONS

*Congratulations on your purchase of this BAR MAID® commercial blender. When used as intended, and with proper care and maintenance, you are sure to experience years of reliable operation from this equipment. To ensure best results, it is important that you read and follow the instructions in this manual carefully. **It is important to keep these instructions in a safe place for future reference.***

Important For Future Reference

Please complete this information and retain this manual for the life of the equipment. For Warranty Service and/or parts, this information is required.

Model Number

Serial Number

Date Purchased



WARNING: IMPROPER INSTALLATION, ADJUSTMENT, ALTERATION, SERVICE OR MAINTENANCE CAN CAUSE PROPERTY DAMAGE, INJURY, OR DEATH. READ THE INSTALLATION, OPERATION, AND MAINTENANCE INSTRUCTIONS THOROUGHLY BEFORE INSTALLING OR SERVICING THIS EQUIPMENT.

AVERTISSEMENT: TOUTE INSTALLATION, RÉGLAGE, MODIFICATION, RÉPARATION OU ENTRETIEN INCORRECT PEUT OCCASIONNER DES DOMMAGES MATÉRIELS, DES BLESSURES GRAVES OU LA MORT. LIRE LES INTRUCTIONS D'INSTALLATION, D'UTILISATION ET D'ENTRETIEN ATTENTIVEMENT AVANT D'INSTALLER OU DE RÉPARER CET APPAREIL.



CAUTION: THESE MODELS ARE DESIGNED, BUILT, AND SOLD FOR COMMERCIAL USE ONLY. IF THESE MODELS ARE POSITIONED SO THE GENERAL PUBLIC CAN USE THE EQUIPMENT, MAKE SURE THAT CAUTION SIGNS, WARNINGS, AND OPERATING INSTRUCTIONS ARE CLEARLY POSTED NEAR EACH UNIT SO THAT ANYONE USING THE EQUIPMENT WILL USE IT CORRECTLY AND NOT INJURE THEMSELVES OR HARM THE EQUIPMENT.

ATTENTION: CES MODÈLES SONT CONÇUS, FABRIQUÉS, ET VENDUS POUR UN USAGE COMMERCIAL SEULEMENT. SI CES MODÈLES SONT PLACÉS POUR QUE LE GRAND PUBLIC PUISSE LES UTILISER, ASSUREZ-VOUS QUE LES CONSIGNES D'ATTENTION, D'AVERTISSEMENT, ET LES INSTRUCTIONS D'UTILISATION SOIENT CLAIEMENT AFFICHÉES PRÈS DE CHAQUE UNITÉ DE SORTE QUE N'IMPORTE QUEL UTILISATEUR DE L'APPAREIL L'EMPLOIE CORRECTEMENT ET NE SE BLESSE PAS OU N'ENDOMMAGE PAS L'APPAREIL.



WARNING: A FACTORY AUTHORIZED SERVICE PROVIDER SHOULD HANDLE ALL MAINTENANCE AND REPAIR. BEFORE DOING ANY MAINTENANCE OR REPAIR, FOLLOW SERVICE SET UP ARRANGEMENT ON PAGE 10.

AVERTISSEMENT: UN TECHNICIEN AUTORISÉ PAR L'USINE DEVRA EFFECTUER TOUT L'ENTRETIEN ET LES RÉPARATIONS. AVANT DE FAIRE TOUT ENTRETIEN OU RÉPARATION, VEUILLEZ CONTACTER WINCO.

Introduction

Congratulations on the purchase of your Bar Maid® Equipment. Please take time to carefully read through this manual to ensure the machine is operated and maintained properly for best possible performance from the product for many years.

Bar Maid® will Not accept liability for the following:

- The instructions in this manual have not been followed correctly.
- Non-authorized personnel have tampered with the machine.
- Non-original spare parts are used.
- The machine has not been handled and cleaned correctly.
- There is any use damage to the unit.

Immediately Inspect for Shipping Damage

All containers should be examined for damage before and during unloading. The freight carrier has assumed responsibility for its safe transit and delivery. If equipment is received damaged, either apparent or concealed, a claim must be made with the delivering carrier.

- A. Apparent damage or loss must be noted on the freight bill at the time of delivery. It must then be signed by the carrier representative (Driver). If this is not done, the carrier may refuse the claim. The carrier can supply the necessary forms.
- B. If concealed damage or loss is not apparent until after equipment is uncrated, a request for inspection must be made to the carrier within 15 days. The carrier should arrange an inspection. Be certain to keep all contents and packaging material.



Table of Contents

Specifications.....	1
Warnings	2
Introduction	2
Table of Contents	3
Packaging	3
Important Safeguards	4
Operation	6
Cleaning, Care & Maintenance	6
Safety & Troubleshooting	7
Exploded View	8
Parts List	9
Limited Warranty	10

Package Contents

All units come with an Operating Instruction Manual and the following:

- XLB-1000 Commercial Blender Base
- 68oz (2 L) Blender Container & Lid
- Tamper
- Blade Removal Tool

Bar Maid® prides itself on quality and service, ensuring that at the time of packing, all products are supplied fully functional and free of damage. Should you find any damage as result of freight, please contact your Bar Maid® dealer immediately.

Function and Purpose

This unit is intended to be used in commercial food-service operations only. It is not intended for household, industrial or lab use.

Installation and start-up must be performed by a qualified installer who has thoroughly read, understands and follows these instructions.

Please keep this manual in a safe place for future use!

NOTE

Please remember that this manual and the warning labels do not replace the need to be alert, to properly train and supervise operators, and to use common sense when using this equipment.

Installation

These instructions should be followed at all times. Failure to follow these instructions could result in injury to yourself and others.

WHEN USING ELECTRICAL APPLIANCES, BASIC SAFETY PRECAUTIONS AND COMMON SENSE SHOULD BE FOLLOWED, INCLUDING BUT NOT LIMITED TO THE FOLLOWING:

1. Read this manual thoroughly before installation and operation. DO NOT proceed with installation and operation if you have any questions or do not understand anything in this manual. Contact your representative or the manufacturer first.
2. DO NOT touch any surfaces that may be hot.
3. Unplug from outlet when not in use prior to installing or removing parts and before cleaning. Allow for the device to cool first before handling.

	<p>⚠ WARNING ⚠ Electrical Shock Hazard</p>	<p>⚠ AVERTISSEMENT ⚠ Risque de choc électrique</p>
	<p>Keep water and other liquids from entering the inside of the unit. Liquid inside the unit could cause an electrical shock.</p> <p>Do not spray water or cleaning products. Liquid could contact the electrical components and cause a short circuit or an electrical shock. Do not use unit if power cord is damaged or has been modified.</p>	<p>Conserver l'eau et d'autres liquides de pénétrer à l'intérieur de l'appareil. Liquide à l'intérieur de l'appareil pourrait provoquer un choc électrique.</p> <p>Ne pas pulvériser de l'eau ou des produits de nettoyage. Le liquide pourrait contacter avec les composants électriques et causer un court-circuit ou un choc électrique. Ne pas utiliser l'appareil si le cordon d'alimentation est endommagé ou a été modifié.</p>

4. To protect against the risk of electrical shock, do not immerse the appliance, cord or plug in water, or other liquids.
5. DO NOT operate this device or any other electrical equipment with a damaged cord or plug, or after the unit malfunctions, is dropped or damaged in any manner. Return to the nearest WINCO Authorized Service Center for examination, repair and/or adjustment.
6. The use of accessory attachments not recommended by WINCO may cause fire, electric shock or injury.
7. Not intended for outdoor installation.

	<p>⚠ WARNING ⚠ Fire Hazard</p>	<p>⚠ AVERTISSEMENT ⚠ Risque d'incendie</p>
	<p>Correct installation precautions, procedures and regulations must be followed. Operation and safety training is necessary for all users of this equipment.</p>	<p>La surchauffe des vapeurs d'huile ou de l'huile peut s'enflammer et provoquer un incendie. Surveillez la température, la qualité et le niveau d'huile. Utilisez et entretenez le système d'élimination des vapeurs d'huile.</p>

8. DO NOT let the cord hang over the edge of a table or counter, or touch hot surfaces.
9. DO NOT place on or near a hot gas or electric burner, or in a heated oven.
10. This appliance should always be on a stable and steady countertop or table. Allow sufficient space around the cooking area. Never use the unit on/near low-heat-resistant materials (carpet, vinyl).
11. This appliance is not intended for use by individuals (including children) with reduced or impaired physical, sensory or mental capabilities, or lack of experience or knowledge, unless they have been given proper supervision or instruction concerning the use of this appliance by a person responsible for their safety.
12. Clean with Caution - if a wet sponge or cloth is used to wipe spills on a hot cooking surface, exercise caution to avoid steam burns. NOTE: some cleaners may produce noxious flames when applied to a hot surface.
13. DO NOT use any objects that are not intended for use with the appliance in the container or near the blades as they can break the motor, overheat and/or cause injury.
14. Do not store any item on top of this unit when in operation.
15. Never place materials such as paper, cardboard, plastic, etc. on or under this unit.
16. If an extension cord power-supply is used,
 - a. The marked electrical rating of the extension cord should be rated the same or greater than the electrical rating of the unit.
 - b. Do not allow cord to hang over a counter or table, touch hot surfaces or become knotted to avoid damage.

Operation

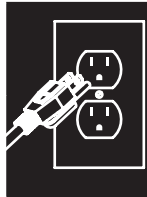

Proper Grounding

**USE A GROUNDED OUTLET
DO NOT ADD AN ADAPTOR TO THE PLUG**

This machine is provided with a three-pronged grounding plug. The outlet to which this plug is connected must be properly grounded. If the receptacle is not the proper grounding type, contact an electrician. DO NOT, under any circumstances, cut or remove the third ground prong from the power cord or use any adapter plug.

Mise à la terre correcte

**UTILISER UNE PRISE AVEC MISE À LA TERRE
NE PAS AJOUTER UN ADAPTATEUR SUR LA FICHE**

Cette machine est équipée d'une fiche à trois broches. La prise sur laquelle cette fiche est branchée doit être correctement mise à la terre. Si la prise n'est pas le type de mise à la terre, contactez avec un électricien. NE PAS, en aucun cas couper ou enlever la troisième broche de terre à partir du cordon d'alimentation ou utiliser un adaptateur.

1. The toggle switch should be in the OFF (0) position.
2. Unwind the power cord fully and plug into a properly grounded 120 volt power supply.
3. Secure the container on top of the base. **INSPECT THE CONTAINER ASSEMBLY, DO NOT USE IF CHIPPED OR CRACKED.**
4. Add ingredients as desired.
5. Place lid on container.

⚠ WARNING ⚠ DO NOT operate blender without lid in place. DO NOT overfill container.

6. Turn on and increase speed to achieve desired consistency.
7. **DO NOT ALLOW FOREIGN OBJECTS TO COME INTO CONTACT WITH THE BLADE WHILE IT IS ON AND ROTATING.**

⚠ WARNING ⚠ DO NOT remove container from base while blender is on and operating.

8. When blending is complete, turn off and allow blade to come to a complete stop before removing container from the base.

The blender has a safety which will prevent it from spinning unless the container is properly secured to the base. Removing the container will automatically stop the unit - DO NOT remove container while blender is running as it can cause damage to the gears between the base and container.

⚠ CAUTION ⚠ DO NOT use the tamper without the container lid securely on.

WHEN USING THE TAMPER: insert tamper through filler cap opening to stir. **DO NOT REMOVE THE LID.** If the lid is completely removed, the tamper may come into contact with the blades causing damage to the blades and/or motor and possibly personal injury.



⚠ WARNING ⚠

Cut Hazard

Correct installation precautions and operating procedures must be followed. Operation and safety training is necessary for all users of this equipment.

⚠ AVERTISSEMENT ⚠

Risque de coupure

Des précautions d'installation et des procédures d'exploitation correctes doivent être suivies. Une formation au fonctionnement et à la sécurité est nécessaire pour tous les utilisateurs de cet équipement.

**⚠ WARNING ⚠ DO NOT leave blender unattended while it is operating.
Unplug from power source when not in use.**

Cleaning, Care & Maintenance

To maintain the appearance and increase its service life, this equipment must be cleaned and dried thoroughly. Clean all surfaces before use. Failure to clean surfaces before using the unit could cause food contamination. The unit may require more frequent cleaning, depending on the volume of production.

1. Wash, rinse, sanitize and dry container prior to initial use, and whenever it will not be used again within a period of 1 hour. Follow manufacturer's instructions for detergent and sanitizer concentration.
2. Half fill the container with warm water and a non-sudsing detergent.
3. Attach the lid and lid plug.
4. Turn the machine ON and gradually increase the speed to MAX and run for 60 seconds.
5. Turn off, remove container and rinse with clear warm water.
6. Fill container with sanitizing solution, cover and run for 60 seconds.
7. Remove the lid and lid plug, and wash along with the tamper in warm soapy water. Rinse and dry with a soft cloth.
8. The power base can be wiped off with a damp cloth.
9. DO NOT use a dishwasher to clean, unless the blade block assembly has been removed.

NOTE: Blade block assembly is Not dishwasher safe

DO NOT immerse the device completely in water for any reason.

DO NOT use a pressure washer to clean.

DO NOT wash parts in an automatic dishwasher.

NOTE: Proper cleaning instructions must be followed; otherwise, operation of the unit may be seriously impaired.

WINCO® authorized service personnel must perform any other servicing.

Troubleshooting

If your BAR MAID® blender does not operate, please check the following prior to placing a service call:

PROBLEM	POSSIBLE CAUSE	RECOMMENDED SOLUTION
The unit is not turning on	Power supply	Check that the power supply cord is correctly plugged in and the outlet is working.
	Breaker has blown	Reset the breaker button on the rear base of the unit.
	Container is not sitting on base properly	Make sure container is secured to the base correctly.
	Power switch has not been turned on	Check that the unit is plugged in and turned on.
	Plug, cord or external wiring is damaged	Call WINCO to make service arrangements through their service provider network.
	Internal wiring fault	
The unit is vibrating too much	Unit is not on stable surface	Place the unit on a level surface or on top of a vibration resistant surface such as a rubber mat.
	Lid is not on properly	Adjust the lid so that it fits tightly and is centered on the container.
	Loose hardware	Tighten any loose screws, nuts or bolts.

Service and Repair

THIS EQUIPMENT MUST ONLY BE SERVICED BY AN AUTHORIZED AGENT.

NOTE

PARTS PROTECTED BY THE MANUFACTURER OR ITS AGENT ARE NOT TO BE ADJUSTED BY THE INSTALLER UNLESS THE INSTALLER IS AN AUTHORIZED SERVICE AGENT.

If you have any questions or problems DO NOT send unit to WINCO® without first contacting our customer service department. See "Limited Warranty" section on page 10 for details.

Commercial Blender



Exploded View

MODEL XLB-1000

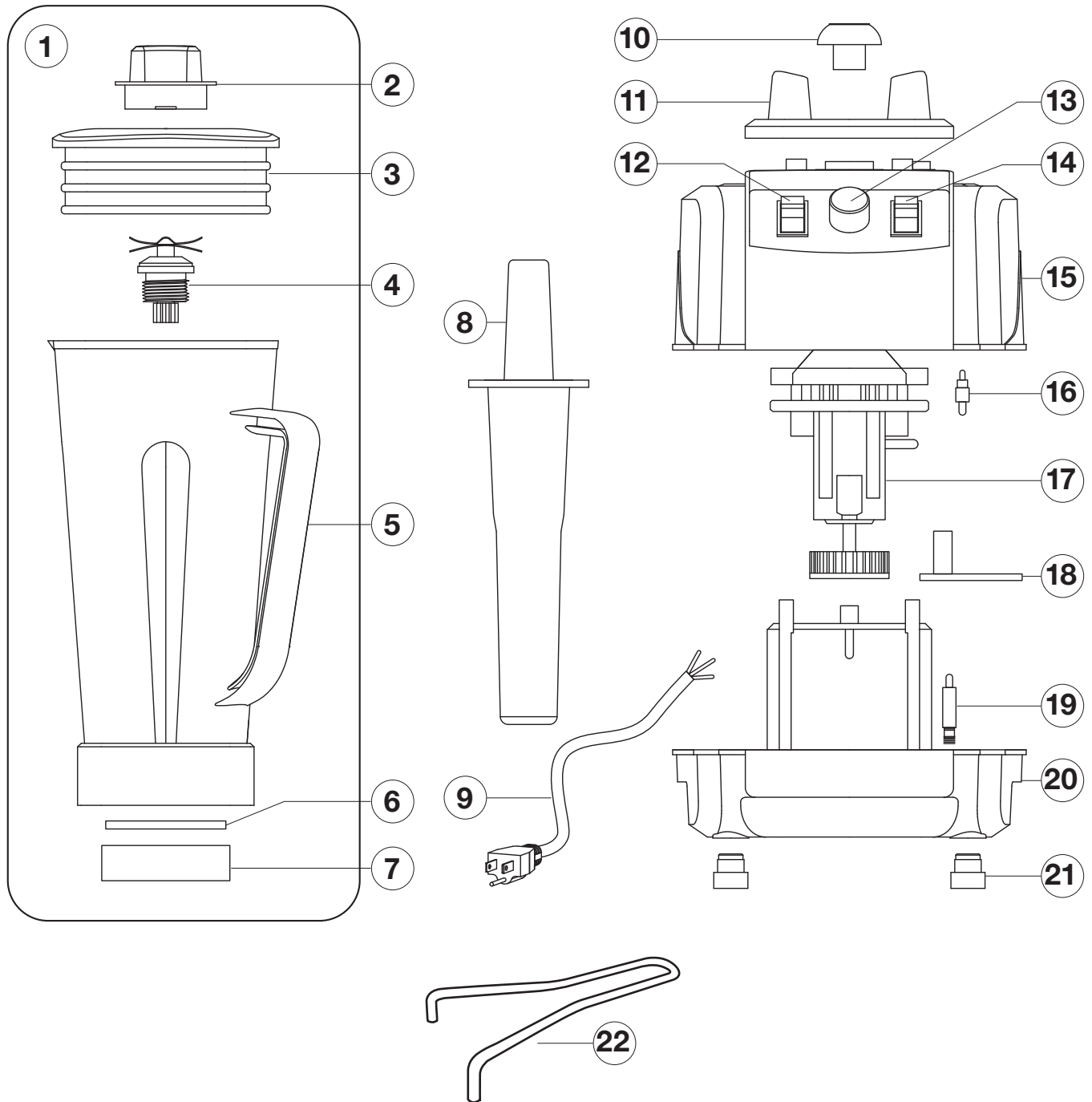

Parts List

MODEL XLB-1000

#	DESCRIPTION	Qty	Part #
1	Container set (#2-7)	1	XLB1000P2
2	Refilling cap	1	XLB1000P4
3	Lid	1	XLB1000P3
4	Blade assembly	1	XLB1000P5
5	Pitcher	1	XLB1000P11
6	Gasket	1	XLB1000P12
7	Blade fixing block	1	XLB1000P13
8	Rod Set	1	XLB1000P1
9	Power cord	1	XLB1000P15
10	Mushroom head	1	XLB1000P10
11	Coaster	1	XLB1000P6
12	Power switch	1	XLB1000P8
13	Speed control knob	1	XLB1000P7
14	Pulse Switch	1	XLB1000P8
15	Upper cover	1	<i>Contact Factory</i>
16	Safety Switch	1	XLB1000P14
17	Motor	1	XLB1000P17
18	PCB Board	1	XLB1000P18
19	Over current Micro Switch	1	XLB1000P16
20	Bottom	1	<i>Contact Factory</i>
21	Rubber feet	4	XLB1000P9
22	Blade Removal Tool	1	XLB1000P19

Please contact factory for special order parts not listed.

Limited Warranty

NOTE: WARRANTY DOES NOT COVER BLADES OR CONTAINER PARTS.

WINCO® warrants to the original purchaser of new equipment that said equipment, when installed in accordance with our instructions within North America and subjected to normal use, is free from defects in material or workmanship for a period of 1 year. The labor warranty is one year from original purchase date or 18 months from actual factory shipment date, whichever date occurs first.

THIS WARRANTY IS IN LIEU OF ALL OTHER WARRANTIES, WHETHER EXPRESSED OR IMPLIED. WINCO EXPRESSLY DISCLAIMS ANY IMPLIED WARRANTY OF MERCHANTABILITY OR EXPRESSED OR IMPLIED WARRANTY OF FITNESS FOR A PARTICULAR PURPOSE.

WINCO'S OBLIGATION AND LIABILITY UNDER THIS WARRANTY IS EXPRESSLY LIMITED TO REPAIRING AND REPLACING EQUIPMENT THAT PROVES TO BE DEFECTIVE IN MATERIAL OR WORKMANSHIP WITHIN THE APPLICABLE WARRANTY PERIOD.

IN NO EVENT SHALL WINCO BE LIABLE FOR INCIDENTAL OR CONSEQUENTIAL DAMAGES TO BUYER OR ANY THIRD PARTY, INCLUDING, WITHOUT LIMITATION, LOSS OF PROPERTY, PERSONAL INJURY, LOSS OF BUSINESS OR PROFITS OR OTHER ECONOMIC LOSSES, OR STATUTORY OR EXEMPLARY DAMAGES, WHETHER IN NEGLIGENCE, WARRANTY, STRICT LIABILITY, OR OTHERWISE.

This warranty is given only to the first purchaser from a retail dealer. No warranty is given to subsequent transferees.

Warranty does not cover product failures caused by: failure to maintain, neglect, abuse, damage due to excess water, fire, normal wear, improper set up and use. Periodic maintenance is not covered.

This warranty is not in force until such time as a properly completed and digitally signed Installation/Warranty Registration has been received by WINCO within 30 days from the date of installation.

Limited Warranty & Equipment Warranty Registration

WARRANTY SERVICE

DO NOT send unit to WINCO® without first contacting our customer service department: 973-295-3899.

To initiate warranty service please visit our online portal:
<https://www.wincous.com/equipment-portal/>

SCAN FOR ONLINE PORTAL

If having trouble or unable to scan, enter the web address listed above to access the online portal.



Please provide or have the following information available:

- Contact Name, E-mail, and Phone Number
- Company/Organization Name
- Model Number
- Serial Number
- Pictures or Supporting Documentation

Proof of purchase is required to extend warranty more than 1 year from date of shipment from the factory.

THE FOREGOING WARRANTY PROVISIONS ARE A COMPLETE AND EXCLUSIVE STATEMENT BETWEEN THE BUYER AND SELLER. WINCO® NEITHER ASSUMES NOR AUTHORIZES ANY PERSONS TO ASSUME FOR IT ANY OTHER OBLIGATION OR LIABILITY IN CONNECTION WITH SAID EQUIPMENT.

Examples of items not covered under warranty, but not limited to just these items:

1. Natural disasters (ie: earthquakes, tornadoes, hurricanes, etc.), fire, water damage, burglary, accident, theft.
2. Freight damage.
3. Improper installation or alteration of equipment.
4. Use of generic or after-market parts.
5. Repairs made by anyone other than a WINCO® designated service provider.
6. Lubrication.
7. Expendable wear parts, adjustable feet, blown fuses, lamps, etc.
8. Normal product maintenance.
9. Misuse or abuse.
10. Normal wear and tear items such as light bulbs, fuses, and exterior finishes.

Warranty voided if:

1. Product is altered by user
2. Serial number plate is removed
3. Product is installed in a prison or any correctional facility.

~ Please keep this manual in a safe place for future reference ~



Bar Maid[®]
by **wincos**[®]

Model: XLB-1000

www.wincos.com