



Specification:

1. Finish: White
2. Hardware: 242MB(4 pcs)+146MB(2 pcs)
3. Hinge: 700.0537.25+600.1234.05 (4 pcs)
4. Slide: USE58-300-18+US-CLIP-4W (4 set)
5. Jewel Case: TOSSI4-REPL (2 pcs)
6. Lid Stay (2 pcs)
7. Bowl: H8910WH
8. The tolerance is +/- 1/8"

 hardware resources	ITEM#: VN-WAV-60-WH-XX		MATERIAL:		
	FINISH:		WEIGHT:		
PROPRIETARY AND CONFIDENTIAL THE INFORMATION CONTAINED IN THIS DRAWING IS THE SOLE PROPERTY OF HARDWARE RESOURCES INC. ANY REPRODUCTION IN PART OR AS A WHOLE WITHOUT THE WRITTEN PERMISSION OF HARDWARE RESOURCES INC. IS PROHIBITED.	TOLERANCE UNLESS OTHERWISE SPECIFIED: X ±0.20 X.X ±0.10 X.XX ±0.05 ANGULAR: ±0.5°		UNITS:	DRAWN BY: Alexander.W	DATE: Jan-17-19
	DO NOT SCALE DRAWING		SIZE:	APPROVED BY:	DATE:
			SHEET:	RELEASE LEVEL:	REVISION:
			 PROJECTION		9

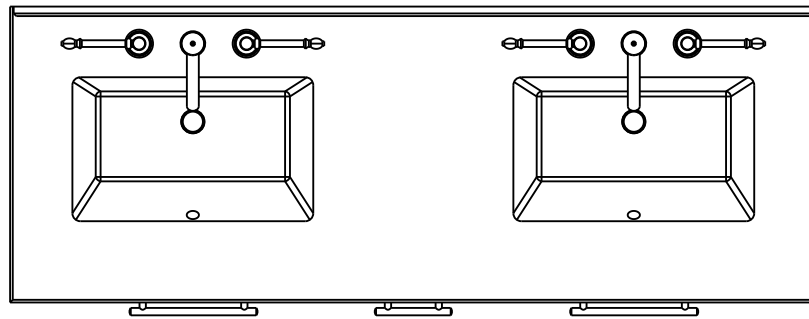
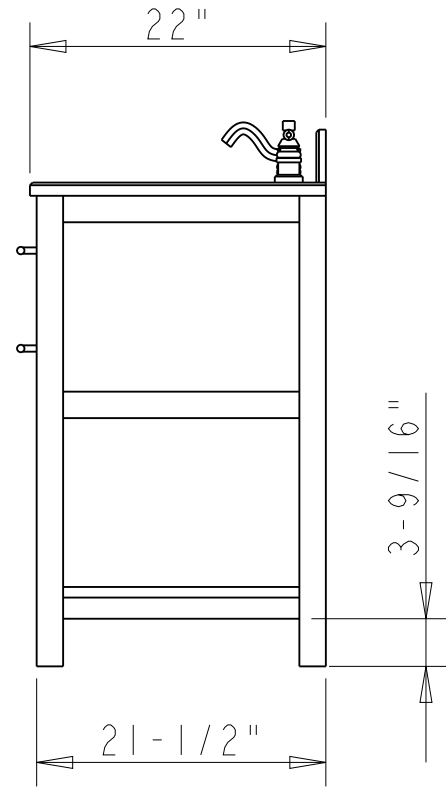
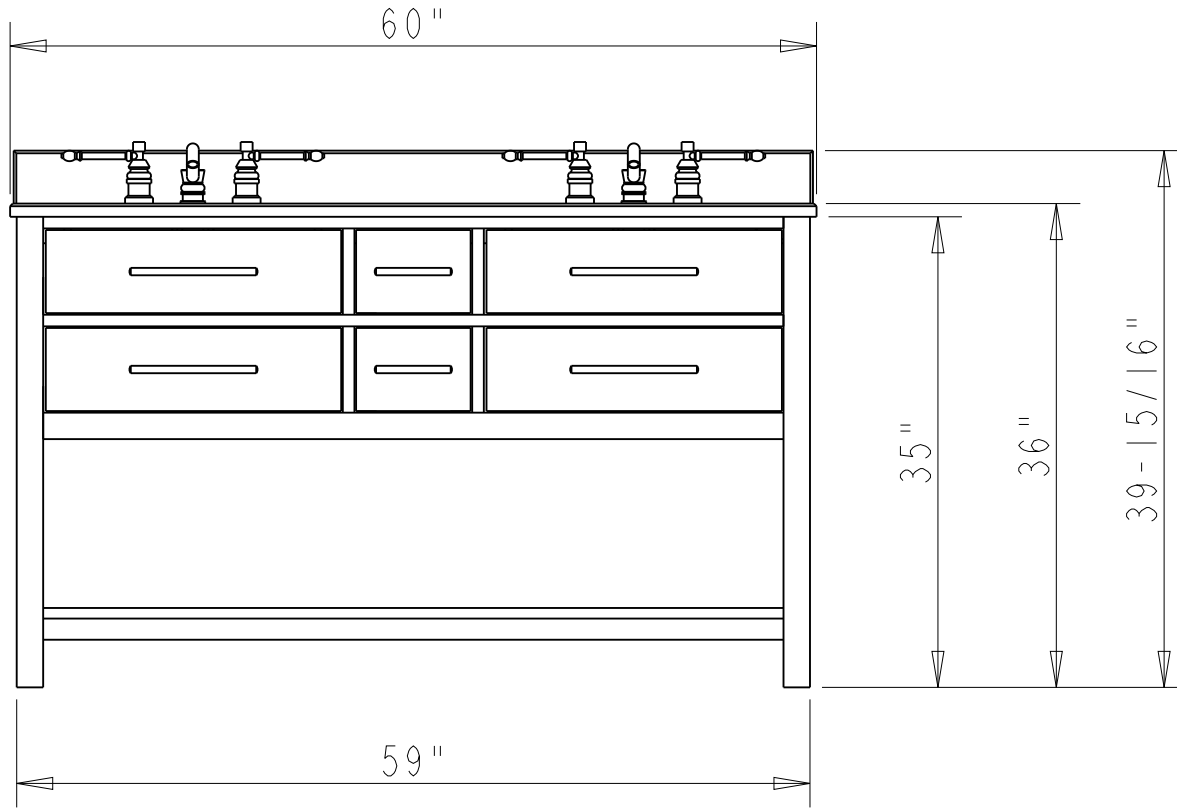

	ITEM#: VN-WAV-60-WH-XX		MATERIAL:		
	FINISH:		WEIGHT:		
PROPRIETARY AND CONFIDENTIAL THE INFORMATION CONTAINED IN THIS DRAWING IS THE SOLE PROPERTY OF HARDWARE RESOURCES INC. ANY REPRODUCTION IN PART OR AS A WHOLE WITHOUT THE WRITTEN PERMISSION OF HARDWARE RESOURCES INC. IS PROHIBITED.	TOLERANCE UNLESS OTHERWISE SPECIFIED: X ±0.20 X.X ±0.10 X.XX ±0.05 ANGULAR: ±0.5°		UNITS: DRAWN BY: Alexander.W	DATE: Jan-17-19	
	DO NOT SCALE DRAWING		APPROVED BY:	DATE:	
			SHEET:	RELEASE LEVEL:	REVISION:
			PROJECTION		

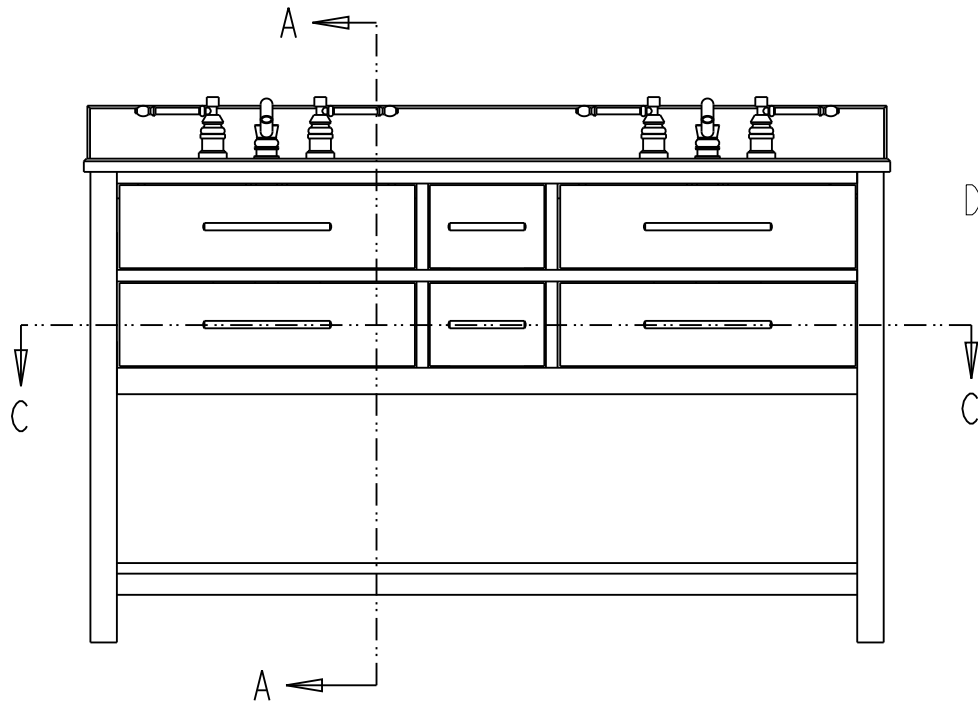

DETAIL A

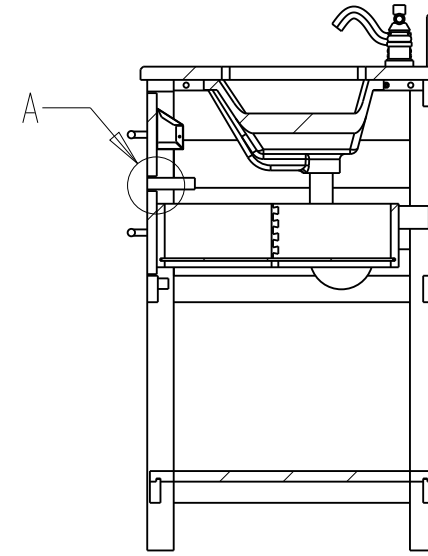

SECTION A-A

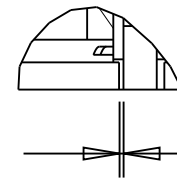

DETAIL B
SCALE 0.200

1/8"

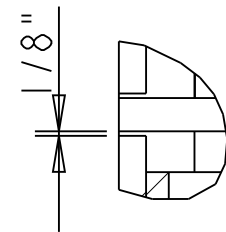

DETAIL A
SCALE 0.200

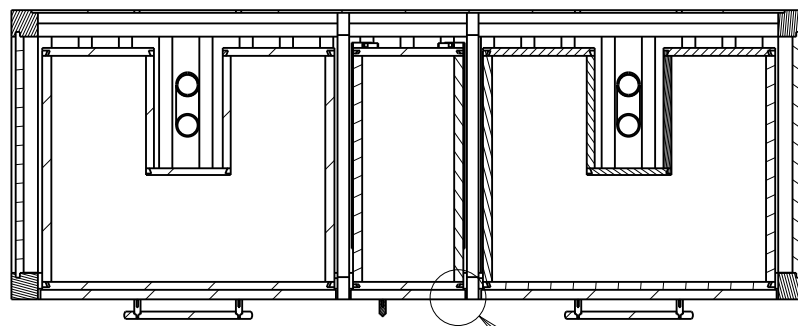

SECTION C-C

DETAIL B

	ITEM: VN-WAV-60-WH-XX	MATERIAL:
	FINISH:	WEIGHT: 9
PROPRIETARY AND CONFIDENTIAL THE INFORMATION CONTAINED IN THIS DRAWING IS THE SOLE PROPERTY OF HARDWARE RESOURCES INC. ANY REPRODUCTION IN PART OR AS A WHOLE WITHOUT THE WRITTEN PERMISSION OF HARDWARE RESOURCES INC. IS PROHIBITED.	TOLERANCE UNLESS OTHERWISE SPECIFIED: X ±0.20 X.X ±0.10 X.XX ±0.05 ANGULAR: ±0.5°	PROJECTION DRAWN BY: Alexander.W DATE: Jan-17-19 APPROVED BY: DATE: SHEET: RELEASE LEVEL: REVISION:
DO NOT SCALE DRAWING		