

# GIBRALTAR

SPECIFICATIONS

# WEATHER VENT™

#63001

26 Gauge Galvanized Steel • Off Ridge Vent • N.F.V.: 104 sq. in. • Rough Opening: 2½ in. x 42 in. • Patent 7,044,852

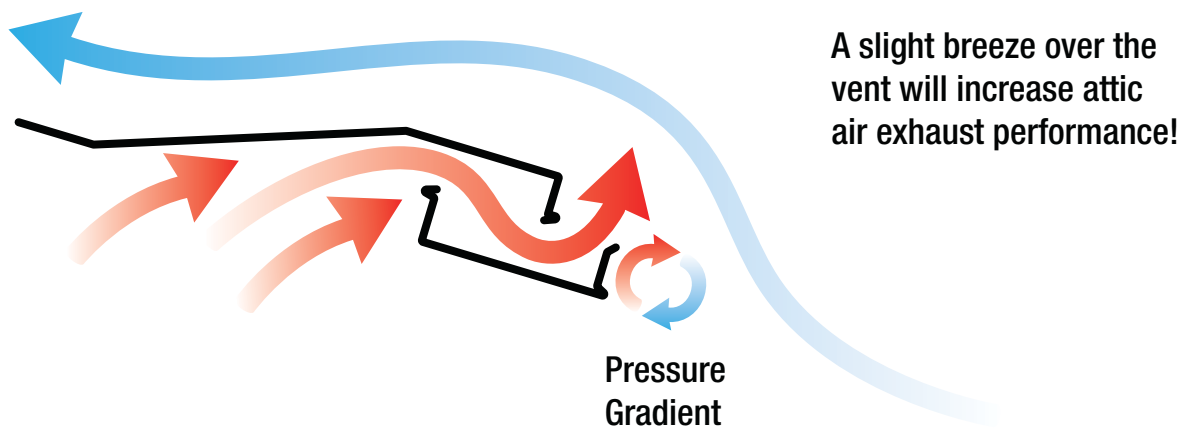
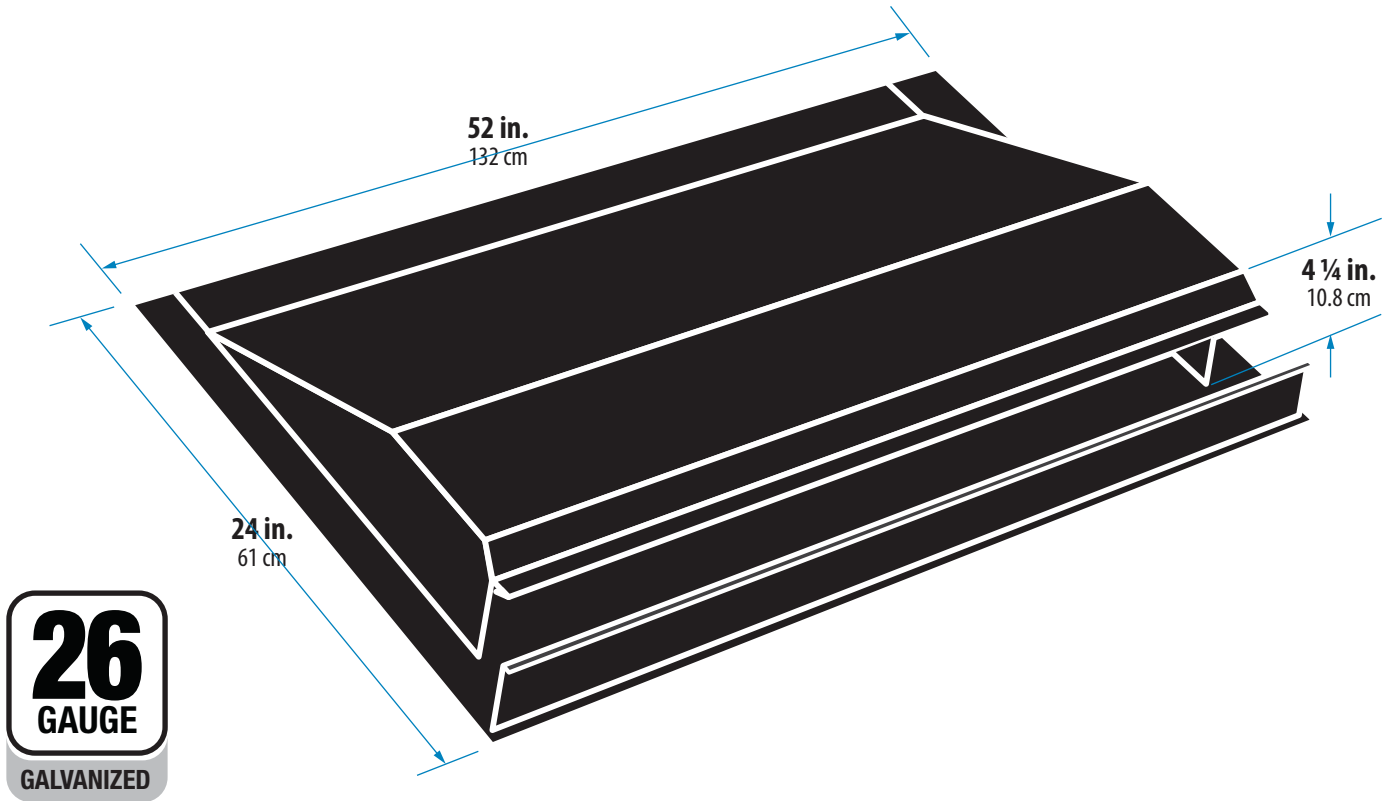

#### Code Approvals<sup>1</sup>

UL Fire Resistant Directory #R20735  
Florida Building #FL-16994.2  
Miami Dade #: NOA No.: 18-1212.10

#### Testing Data & Specifications

Accelerated Testing 2000 hours - ASTM G23  
Salt Spray Testing 1000 hours - ASTM B117  
Fire Testing - ASTM E108 or UL 790  
Wind Driven Rain - TAS 100

1. Code Approval numbers may have changed since publication. For the most recent code approval numbers, contact our Technical Department or refer to the appropriate code agency.