

- NOTES:
 1. REQUIRES A 110V OUTLET
 2. FINISH: MAPLE
 3. HOLDS (1) 35 QT WASTE CONTAINER

CUSTOMER DRAWING

This drawing is the property of Rev-A-Shelf (RAS) and is disclosed in confidence to the extent its subject matter is original to RAS. Any vendor receiving this drawing from RAS shall hold and use this drawing for the sole benefit of RAS and shall not disclose it to, or use or reproduce it for any third party, or perform any act adverse to the interest of RAS with respect to this drawing without the express written permission of RAS. Vendors shall not revise any physical, dimensional or performance characteristic unless authorized by Rev-A-Shelf Engineering.

REV.	DATE	BY	DESCRIPTION OF CHANGE

INCH [MM]	AMERICAN PROJECTION	BY	DATE	REV-A-SHELF, Inc.
		DRAWN	KRR 6-2-11	
MATERIAL				SIZE
FINISH				DRAWING NO.
TOLERANCES				PART NO.
MATERIAL				SCALE
FINISH				SHEET OF
MAT. DEC. (WOOD) .XX ±.03 [.8mm] (OTHER) .XX ±.02 [5mm] (ALL) .XX ±.005 [1.3mm] FRACTIONS ±1/32 [8mm]				4WCSD-1535DM-1 0.150 1 OF 3

OPEN VIEW

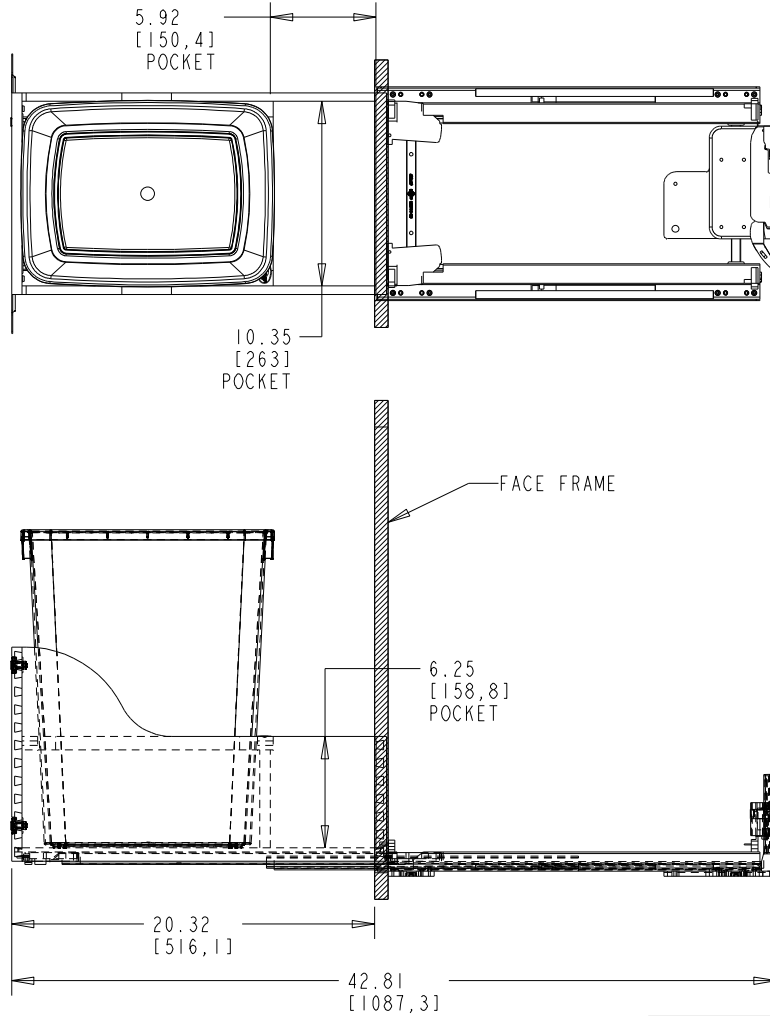
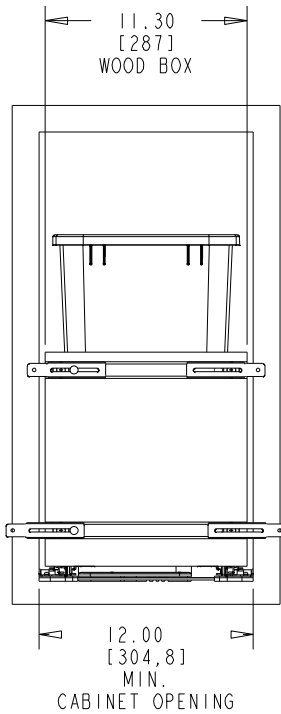

CUSTOMER DRAWING

This drawing is the property of Rev-A-Shelf (RAS) and is disclosed in confidence to the extent its subject matter is original to RAS. Any vendor receiving this drawing from RAS shall hold and use this drawing for the sole benefit of RAS and shall not disclose it to, or use or reproduce it for any third party, or perform any act adverse to the interest of RAS with respect to this drawing without the express written permission of RAS. Vendors shall not revise any physical, dimensional or performance characteristic unless authorized by Rev-A-Shelf Engineering.

REV.	DATE	BY	DESCRIPTION OF CHANGE

INCH [MM]	AMERICAN PROJECTION	BY	DATE	REV-A-SHELF, Inc.
		DRAWN	KRR 6-2-11	
TOLERANCES		SIZE	BLUM WCBM 15" CABINET	
MATERIAL		SINGLE 35 QT - SERVO		
FINISH		DRAWING NO.	4WCSD-1535DM-1_CUST	
ANGLES ±1/2°		PART NO.	4WCSD-1535DM-1	
MAT. DEC. (WOOD) .XX ±.03 [.8mm] (OTHER) .XX ±.02 [.5mm] (ALL) .XX ±.005 [0.13 mm] FRACTIONS ±1/32 [.8 mm]		SCALE	0.150	
REV.		DATE	BY	SHEET 2 OF 3

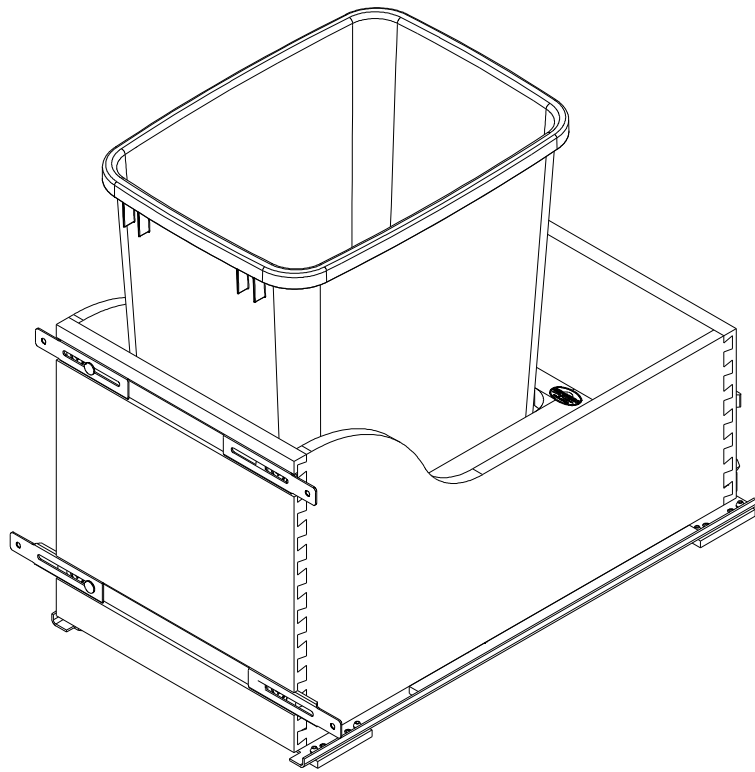

PART DIMENSIONS		
	MIN	MAX
WIDTH	12.00	
DEPTH	22.50	
HEIGHT	19.44	
WEIGHT		
DIAMETER		
RADIUS		
CONTAINER CAPACITY	35	
CONTAINER UOM	QUART	

MIN CABINET OPENING	
WIDTH	12.00
DEPTH	22.50
HEIGHT	19.75

PRODUCT MAX WEIGHT RATING

SLIDE SPECIFICATIONS				
SLIDE TYPE	UNDERMOUNT	SLIDE EXTENSION	FULL	MAX WEIGHT RATING
SLIDE CLOSING	SOFT	SLIDE LENGTH	21"	
SLIDE MOUNTING	BOTTOM	SLIDE FINISH	ZINC	
				110 LB

CUSTOMER DRAWING

This drawing is the property of Rev-A-Shelf (RAS) and is disclosed in confidence to the extent its subject matter is original to RAS. Any vendor receiving this drawing from RAS shall hold and use this drawing for the sole benefit of RAS and shall not disclose it to, or use or reproduce it for any third party, or perform any act adverse to the interest of RAS with respect to this drawing without the express written permission of RAS. Vendors shall not revise any physical, dimensional or performance characteristic unless authorized by Rev-A-Shelf Engineering.

REV.	DATE	BY	DESCRIPTION OF CHANGE	INCH [MM]	AMERICAN PROJECTION	BY	DATE	REV-A-SHELF, Inc.	
						DRAWN	KRR	6-2-11	SIZE B
									BLUM WCBM 15" CABINET
									SINGLE 35 QT - SERVO
									DRAWING NO.
									4WCSD-1535DM-1.CUST
									SCALE
									0.250
									PART NO.
									4WCSD-1535DM-1
									SHEET 3 OF 3

TOLERANCES	
MAT.	DEC.
(WOOD) .XX ±.03 [.8mm]	
(OTHER) .XX ±.02 [.5mm]	
(ALL) .XXX ±.005 [1.3 mm]	
FRACTIONS	±1/32 [.8 mm]

ANGLES
±1/2°

MATERIAL
FINISH