

52-952-0003-00

N Plug to N Plug

DC-18 GHz

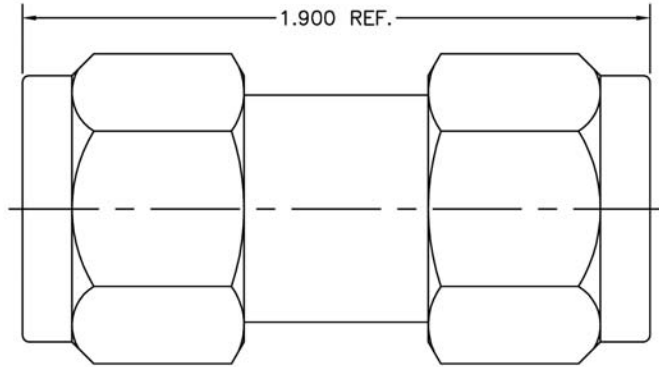

52-953-0000-00

N Plug to N Jack

DC-18 GHz

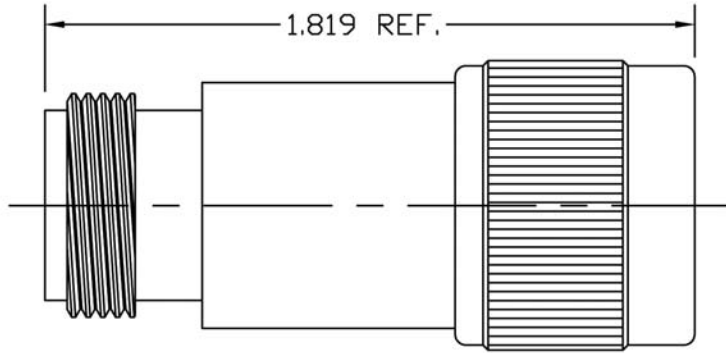

53-953-0000-70

N Jack to N Jack

DC-18 GHz

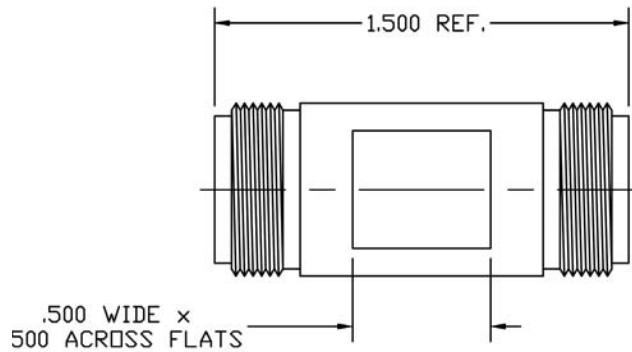

53-953-2040-60

N Jack to N Jack Bulkhead
(Hermetically Sealed)

DC-18 GHz

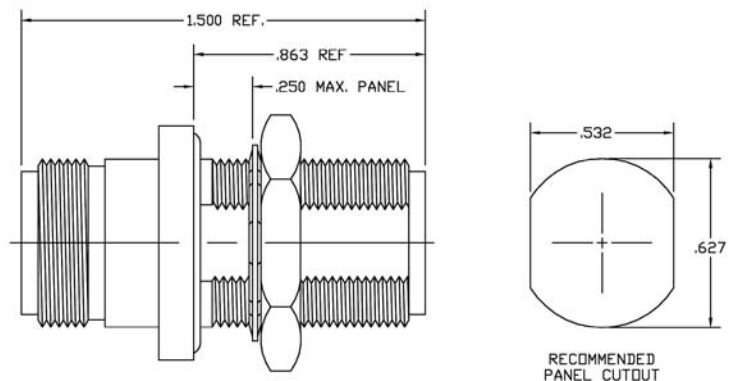

N In-Series Adaptors

53-953-3100-70

N Jack to N Jack
4 Hole Flange Mount

DC-18 GHz

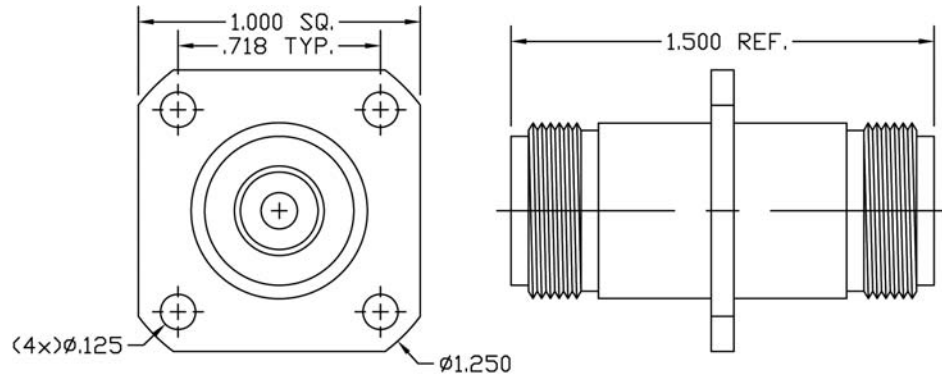

Z

53-953-3500-00

N Jack to N Jack
Bulkhead Mount

DC-18 GHz

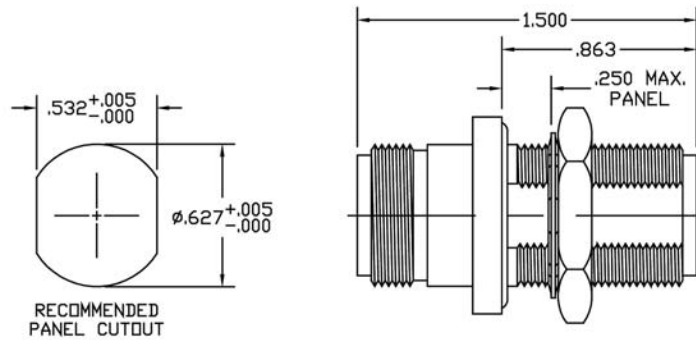

N Cable Connectors

52-000-1529-00

N Plug to HP290 Solder
Clamp

DC-15 GHz

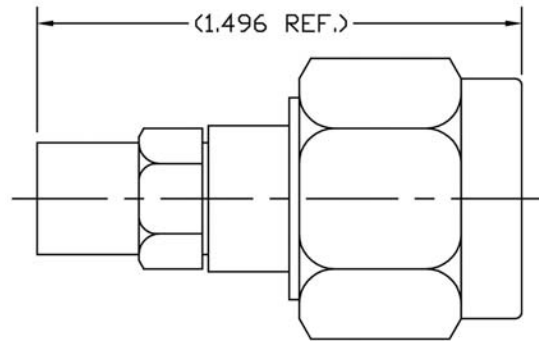

52-000-1531-00

N Plug to Heli-Foil 290
Solder Clamp

DC-18 GHz

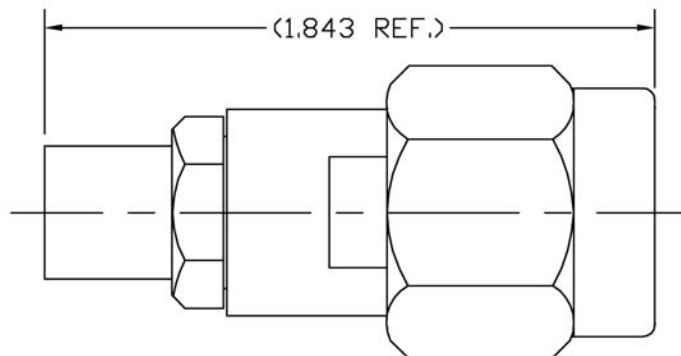

52-000-1542-00

N Plug to HP450
Solder Clamp

DC-12 GHz

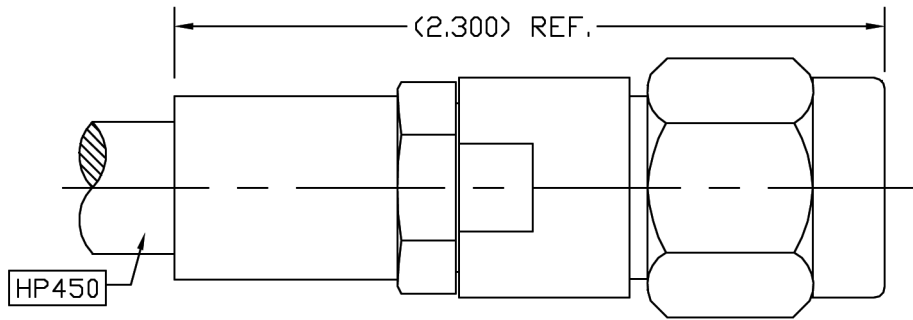

52-000-1580-00

N Plug to IW4806
Solder Clamp

DC-12 GHz

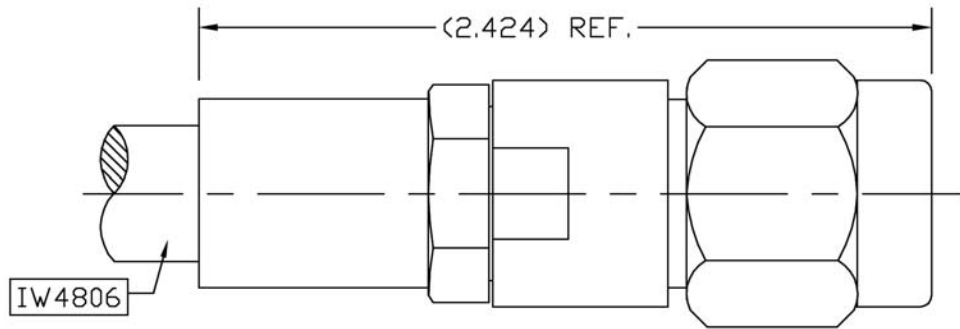

52-000-1585-00

N Plug to .085 S/R
Solder Clamp

DC-18 GHz

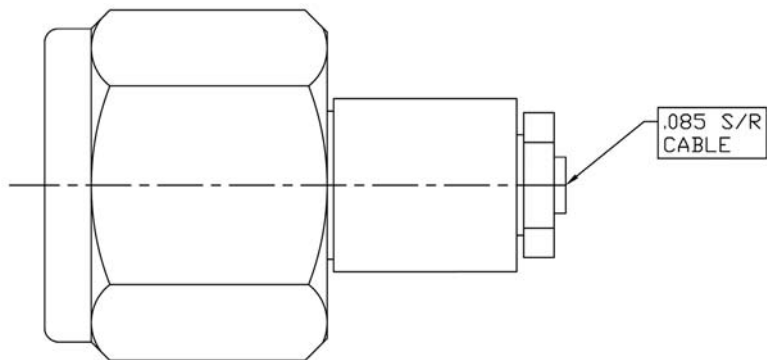

52-000-1598-00

N Plug to LA290
Solder Clamp

DC-18 GHz

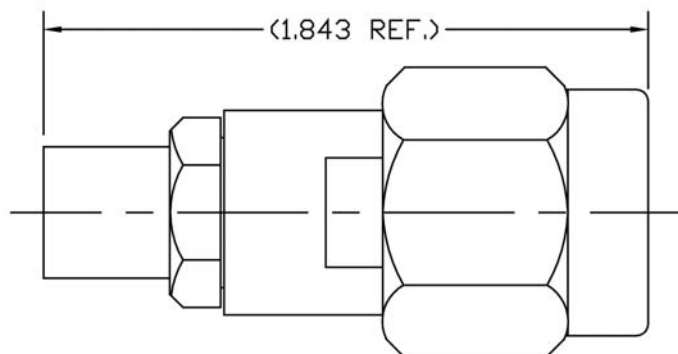

52-041-1597-00

N Plug R/A to LL142
Solder Clamp

DC-18 GHz

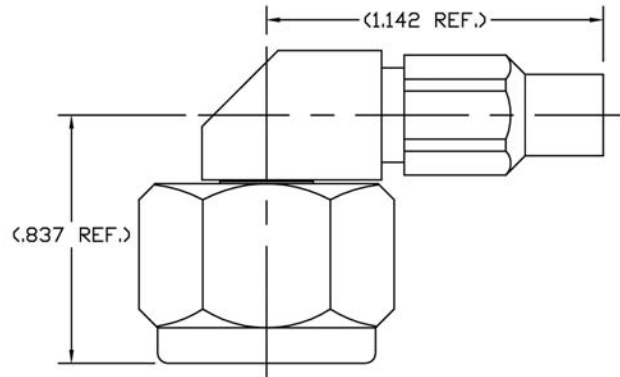

Z

53-000-1536-00

N Jack to LL235 Solder
Clamp

DC-18 GHz

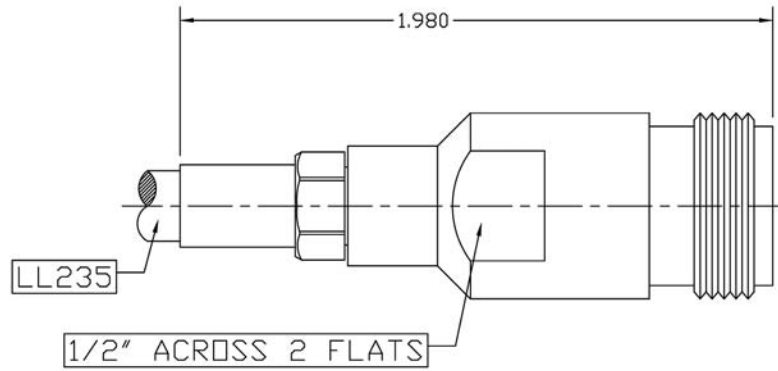

53-000-1541-00

N Jack to .141 S/R Solde
Clamp

DC-18 GHz

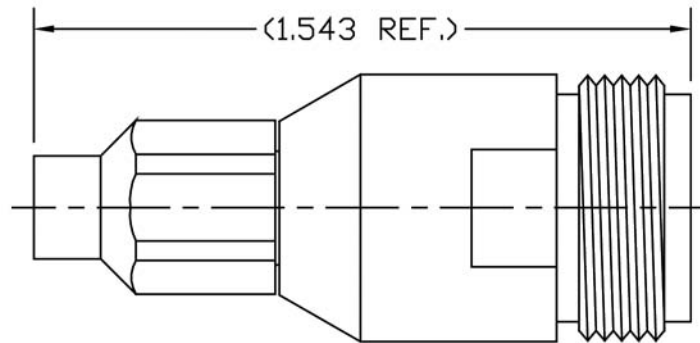

53-000-1568-00

N Jack to FE56 Solder
Clamp

DC-18 GHz

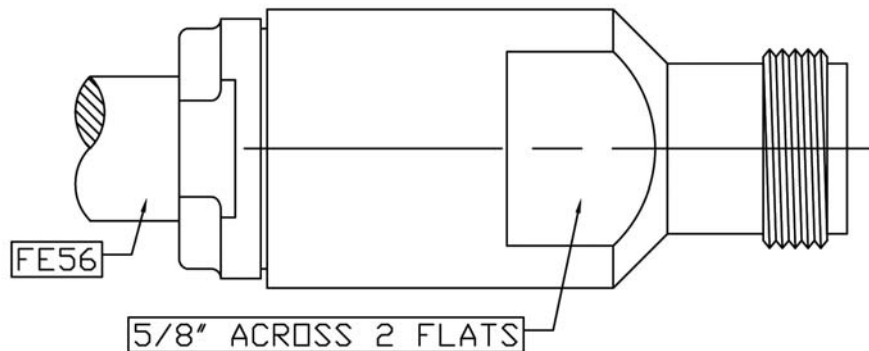

53-000-1590-70

N Jack to HP190 Solder
Clamp

DC-18 GHz

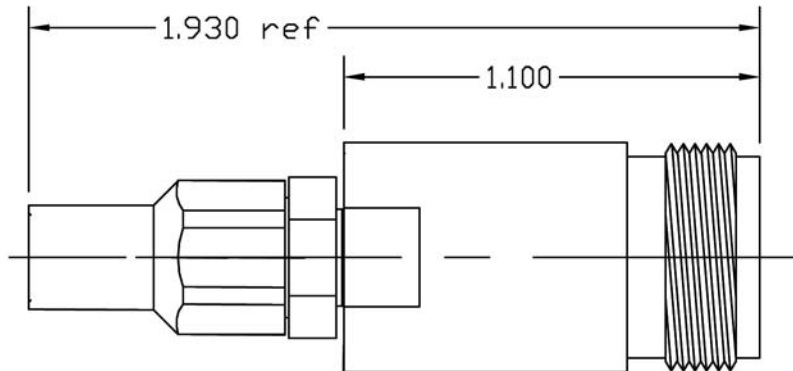

53-020-1535-00

N Jack Bulkhead to LL335
Solder Clamp

DC-18 GHz

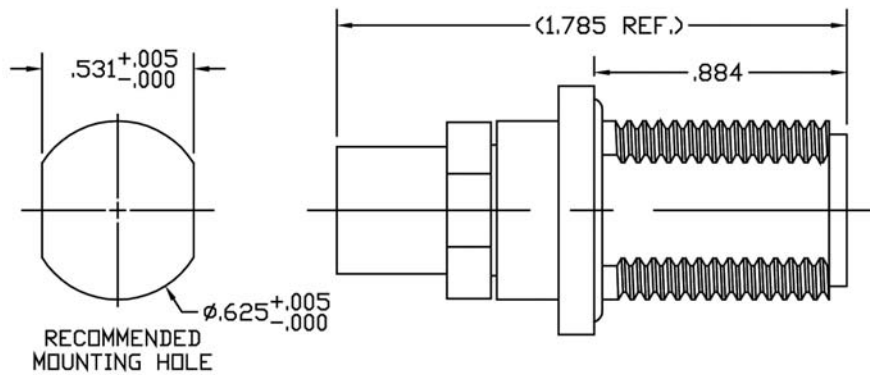

53-020-1541-00

N Jack Bulkhead to .141 S/R
Solder Clamp

DC-18 GHz

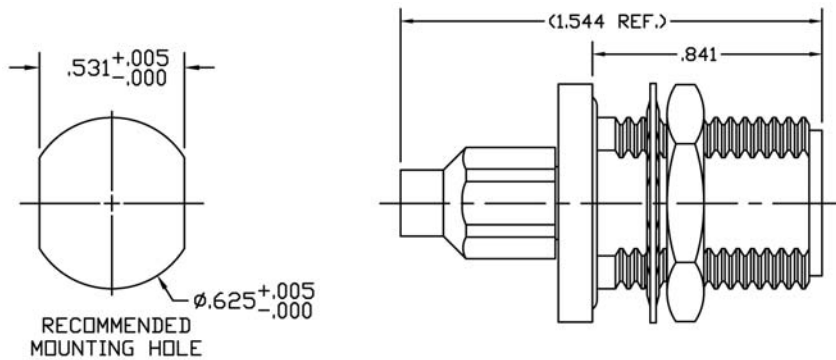

53-020-1542-00

N Jack Bulkhead to HP450
Solder Clamp

DC-18 GHz

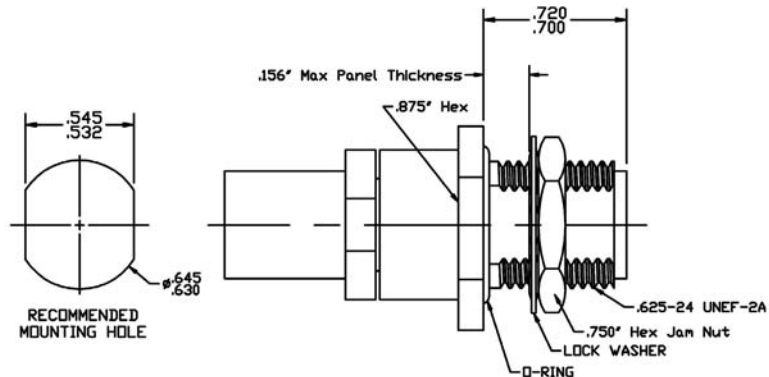

53-020-1559-00

N Jack Bulkhead to SF142B
Solder Clamp

DC-18 GHz

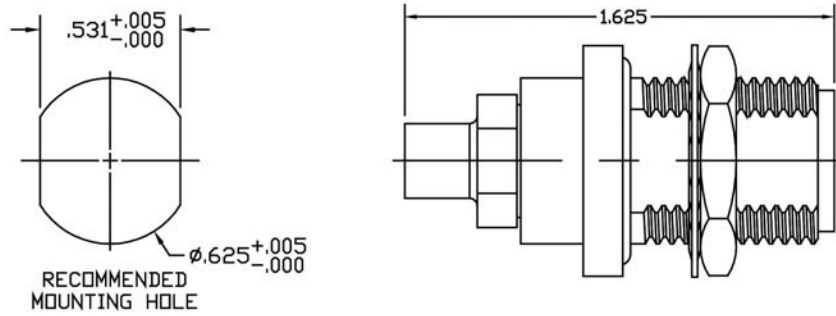

Z

53-020-1569-00

N Jack Bulkhead to FA20X
Solder Clamp

DC-18 GHz

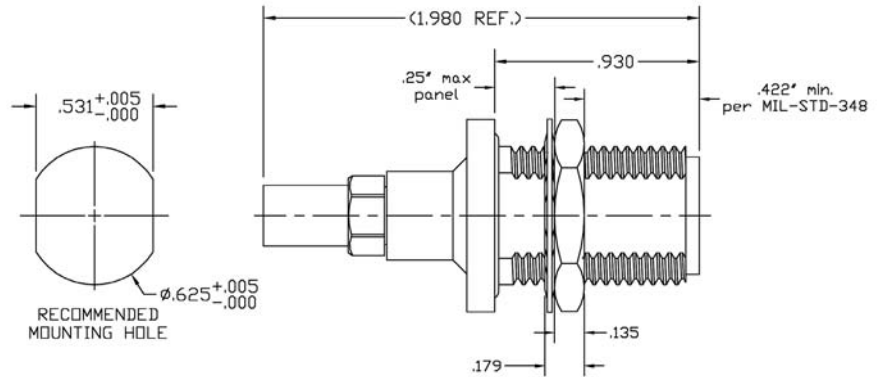

53-020-1580-00

N Jack Bulkhead to IW4806
Solder Clamp

DC-18 GHz

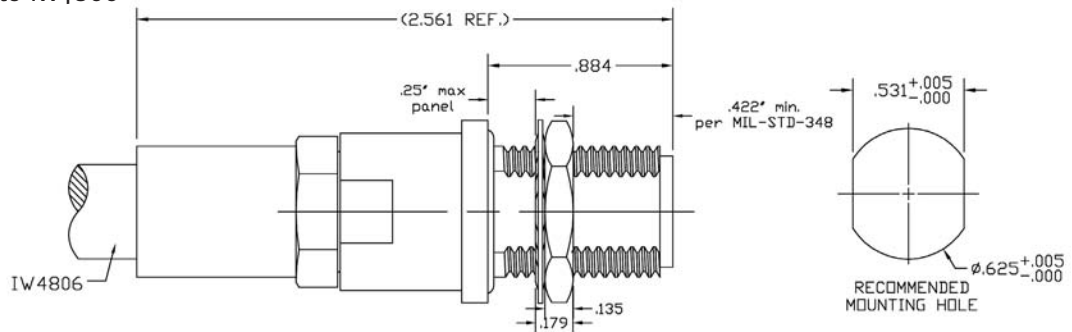

53-020-1585-0

O
N Jack to .085 S/R
Solder Clamp

DC-18 GHz

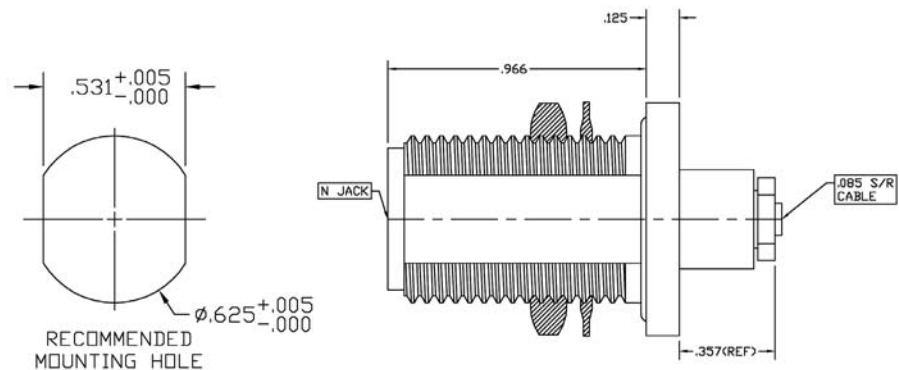

53-031-1541-00

N Jack to .141 S/R
4 Hole Flange Mount
Solder Clamp

DC-18 GHz

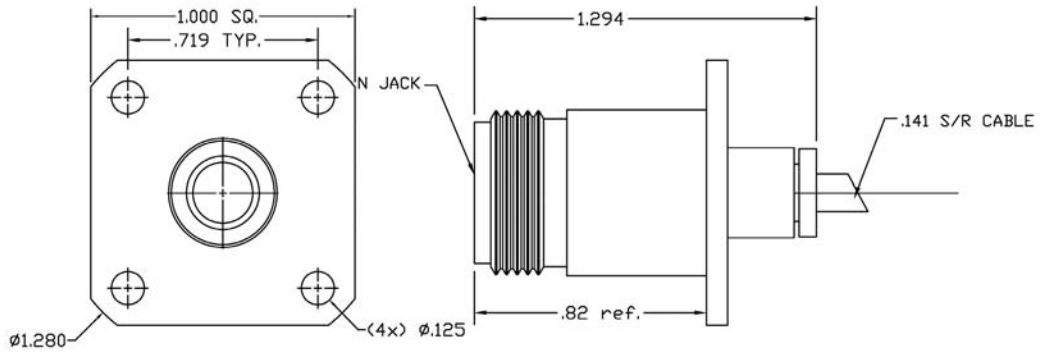

53-041-1542-00

N Jack Bulkhead R/A to HP450
Solder Clamp

DC-18 GHz

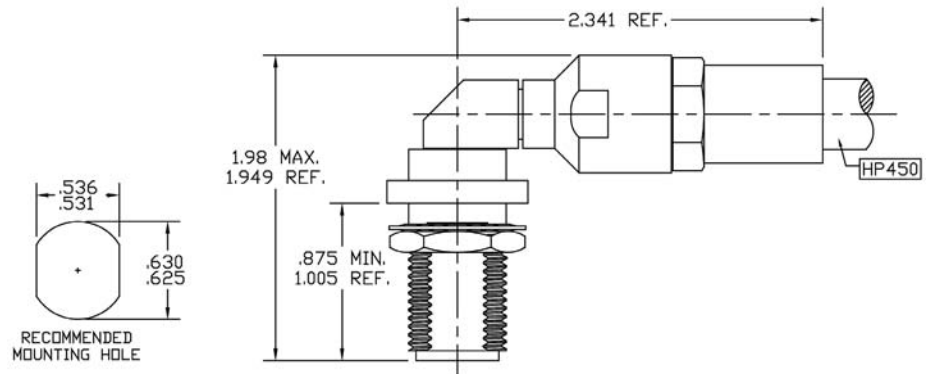

53-041-1568-00

N Jack Bulkhead R/A to HP500
Solder Clamp

DC-18 GHz

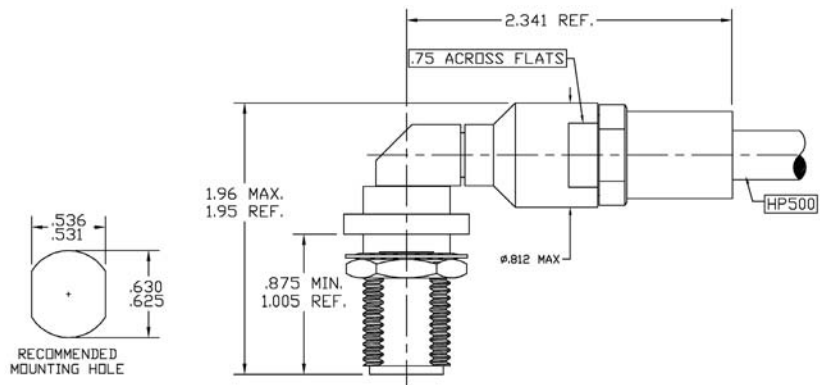

N Receptacles

53-131-1000-00

N Jack Receptacle
4 Hole Flange Mount

DC-18 GHz

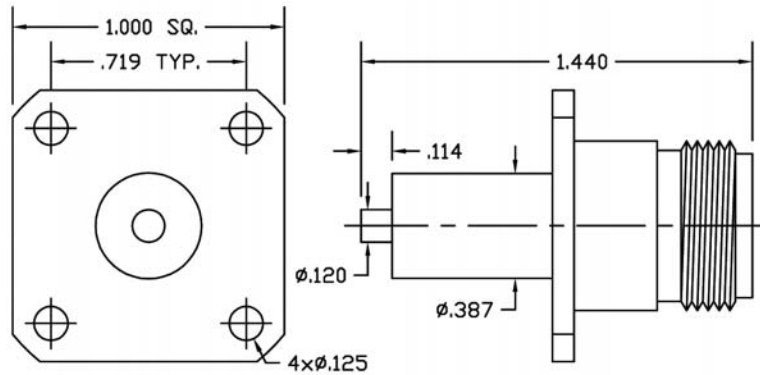

Z

53-131-1000-02

N Jack Receptacle
4 Hole Flange Mount

DC-18 GHz

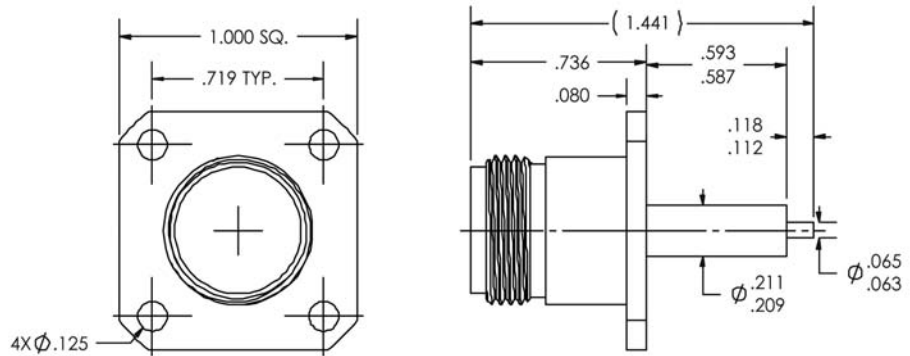

53-131-1500-00

N Jack Receptacle
4 Hole Flange Mount
to Accept .062" Diameter
Pin

DC-10 GHz

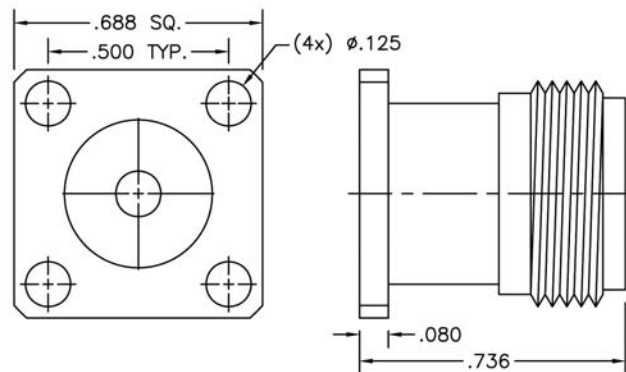

53-131-1500-10

N Jack Receptacle
4 Hole Flange Mount
to Accept .015" Diameter
Pin

DC-15 GHz

