

# T20/26 SERIES



**HILLYARD**  
  
The Cleaning Resource®

 **TRIDENT®**

Better Built. Better Equipment.

# Better Built. Better Equipment.

Our Trident Brand of equipment starts from the ground up - at a place where intelligent design intersects with innovative technology and exceptional engineering to deliver superior cleaning equipment. Cleaning equipment that lowers your total cost of ownership, reduces your cost to clean and improves cleaning results. It's what you expect out of your equipment investment, and it's what we deliver. We're Hillyard, The Cleaning Resource, since 1907.



Intelligent  
Design



Exceptional  
Engineering



Innovative  
Technology



The outer body surrounds the internal structure and mechanical parts, protecting them from impact.

*T20SC Pro pictured with optional light kit.  
Lights standard on T26SC Plus.*

Productivity: Up to 23,00 Sq. Ft. per hour



# Designed to Last a Lifetime

## Innovative Aluminum Chassis Platform

- Corrosion Resistant
- Sturdy and Durable
- Light Weight
- Precision Fit

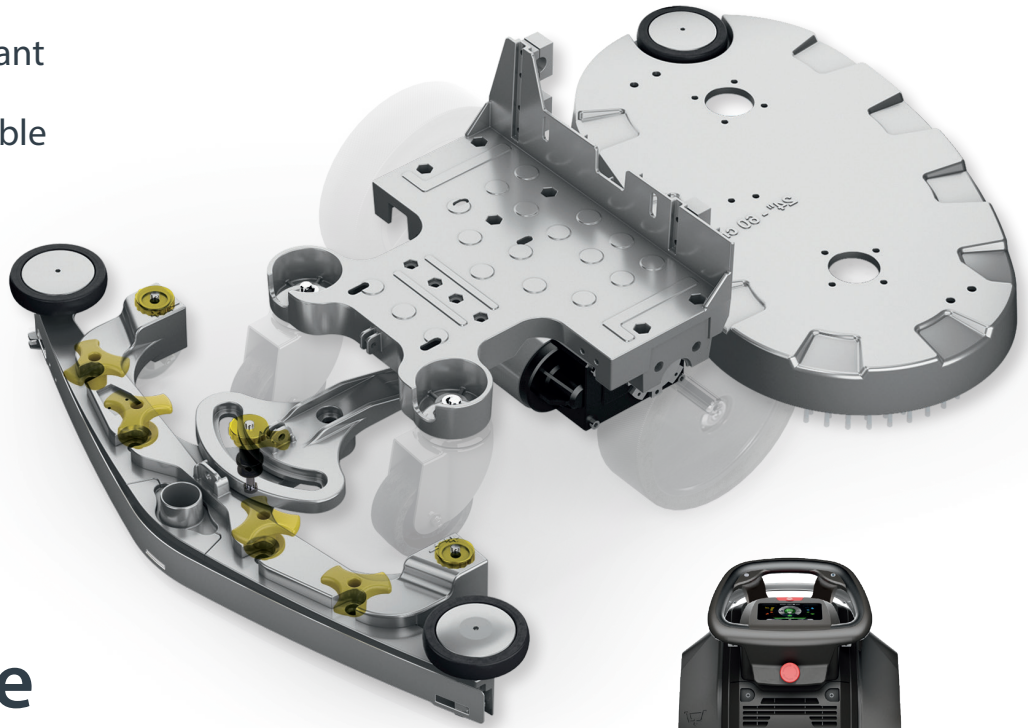

## Ease-Of-Use

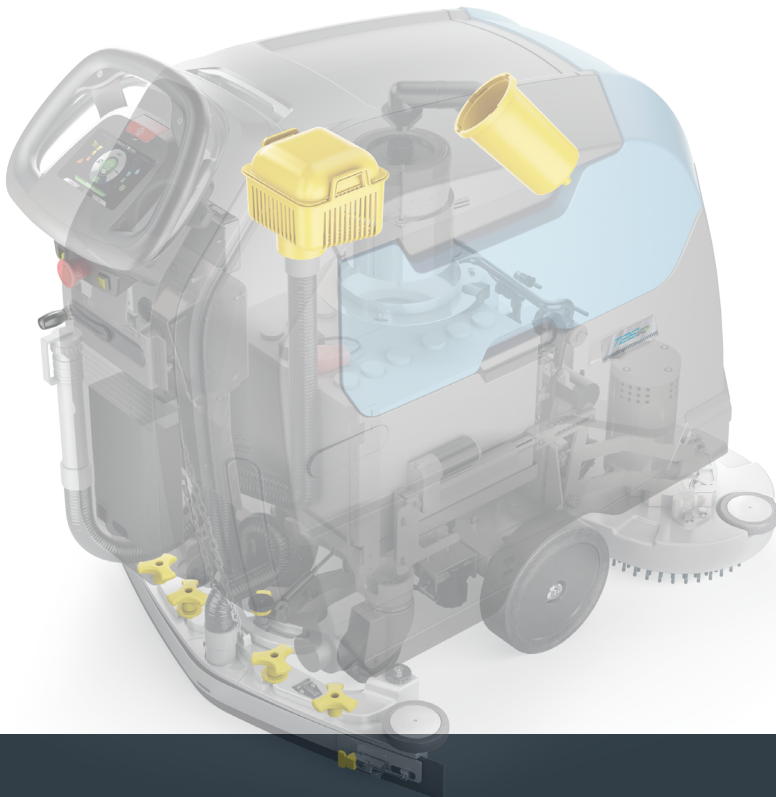

### Yellow Color-Coded Parts

Parts that should be cleaned daily are color-coded in yellow. This saves time and makes sure your scrubber is kept in perfect condition at all times.

## Increase Productivity



### Consistent Cleaning Results

Pressure on the brushes is kept constant, delivering consistent high cleaning results.



### Reduce Downtime

The largest tanks in its class: less stops to fill/empty the tanks.



### Rapid Dry

The powerful 2-stage vacuum motor immediately dries the floor, reducing the chance of slip/falls.



### Start & Stop Technology

When the machine is idle, the brush motor, vacuum motor, traction and detergent pump will turn off automatically, reducing costs and emissions. All the functions are reactivated automatically as soon as the operator accelerates.



## Power Mode For Heavy Soil

Activate the Power Mode to increase the delivery rate of detergent solution, boost brush pressure, and increase vacuum power to tackle heavy duty cleaning. Let Power Mode run for the full length of its 60-second countdown clock, or stop it with a touch at anytime.

**POWER**  
mode





## Safety



### Emergency Stop

By pressing a single button the machine stops immediately.



### LED Lighting

Front LED headlights maximize safety in all conditions. Standard on T26SC Plus, optional on T20SC Pro models.



### Automatic Electro Braking

Automatically operated safety brake engages when the machine stops. It acts as a safety parking brake.



### One-Touch - Service On Site

One-touch service contact in case of emergency. Pushing the red button will automatically send an e-mail to the authorized Hillyard service department on record. The service department can quickly act.



## Eco Mode For Conservation

Activate the Eco Mode to help conserve water, detergent and energy by using only the quantities needed and nothing more while still getting the cleaning performance required.





**PLUS**

**T26SC PLUS**

## Plus Configuration

High-Definition Touch Screen  
Color Display



## Innovative Technology A Finger-Tip Touch Away



TOUCH SCREEN  
DISPLAY



LOG-IN WITH  
PASSWORD



PERSONALIZED  
WORK ZONE  
PROGRAMS



CRUISE  
CONTROL



SUSTAINABLE  
CLEANING



TOUGH  
CLEANING



VIDEO  
TUTORIALS



# Simplified Cleaning and Control

The operator is the center of a high-tech universe, where everything is easy and intuitive.

All functions and activities are managed from a single interface, where a mere touch of the finger offers access to an extraordinary choice of customizable features that satisfy all types of requirements with effortless simplicity.

The high-definition color display offers the same intuitive experience as a smartphone.

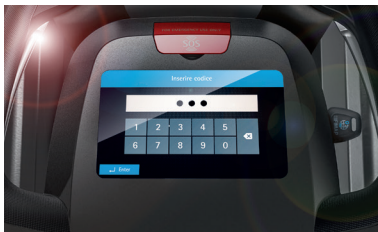

### LOG-IN WITH PASSWORD

Protect your investment and personalize the settings.



### CUSTOM WORK ZONE PROGRAMS

Configure the machine with settings specific to a zone's cleaning needs. The operator simply selects the zone and the settings are automatically applied.



### ECO MODE

Sustainable, cost-effective cleaning. Reduces sound, water and detergent consumption, and saves energy.



### POWER MODE

Maximum power for tough cleaning.

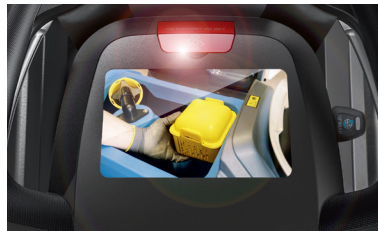

### ONBOARD DIGITAL INSTRUCTIONS

Giving you all the information you need exactly when you need it.

## Pro Configuration *T20SC* PRO

Membrane Control Panel



## Join The Connected Cleaning World\*

Keep tabs on your machines remotely whenever you want and from wherever you want!



### GEOLOCATION

Know where your machines are.



### USAGE DATA

Know who's using your machine and how it is being used.



### MAINTENANCE

Know the health status of machines and batteries.



### TELEMETRY

Critical machine data is always being monitored for peak performance.



## Hillyard Fleet Management



Discover the HFM universe and experience the advantages of being constantly connected, with the My.Machine app!



My.Machine





## Knowledge Is Power

Making technology available to improve efficiency is one of the core missions of Hillyard. It gives you the power to make the right decisions for your cleaning program.

HFM, the Hillyard Fleet Management system collects data sent by connected cleaning machines and transforms it into valuable information. Information that is easily accessible in real time, 24/7, from your smartphone.

Being constantly connected to your machines will help you operate them even more efficiently and effectively. Know where your machines are, and if the operation is being carried out according to plans at the scheduled time.

Machine health is constantly monitored. In the unlikely event of a breakdown, you'll receive an alert notification directly on your smartphone, allowing you to promptly take corrective action and immediately call technical support.

Easily check the battery conditions and the quality of the charges in order to optimize battery endurance and life cycle.

The sensors provide hard impact feedback. Now you will know how the equipment is being used.

It's time to get your cleaning world connected with Hillyard Fleet Management.

## Sustainable Technologies



**TES**

Trident Energy Saver

Reduces energy consumption by up to 35%. LED technology consumes much less energy than conventional headlights, offers a longer lifespan and illuminates with a brilliant natural daylight.



**TDC**

Trident Dosing Control\*

Water and detergent are dosed separately, optimizing cleaning and reducing chemical and water consumption by up to 50%.



**TFC**

Trident Flow Control

Engineered water flow system that delivers equal solution to both scrub brushes ensuring proper coverage to deliver consistent cleaning quality.



\* Optional System



Better Built. Better Equipment.

Standard and Optional Equipment

• STANDARD ○ OPTION - NOT AVAILABLE



Intelligent Drive

User Experience	T20SC Pro	T20SC Pro - Orbital	T26SC Plus
- 5-Inch High-Resolution Color Touch Screen	-	-	•
- Log-In With Password	-	-	•
- "Zone" Program	•	•	•
- Eco Mode	•	•	•
- Power Mode	-	-	•
- Video Tutorials	-	-	•
Membrane Control Panel	•	•	-

**Comfort**

Hour Meter	•	•	•
Key Switch	•	•	•
Cleaning Solution Level Indicator	•	•	•
Water And Detergent Empty Tank Lights	-	-	•
Onboard Battery Charger	○	○	○
Automatic Brush Coupling/Uncoupling	•	-	-
Brush And Squeegee Actuator	-	-	•
Brush Actuator	•	•	-
Squeegee Manual Lifting	•	•	-

**Productivity**

Speed Selector	•	•	•
Water Flow Selector	•	•	•
Tri-Level Pressure Selector	-	-	•
Dual-Level Pressure	•	•	-
HFM - Hillyard Fleet Management With SOS Device	○	○	○
Aluminum Frame, Squeegee & Squeegee Support	•	•	•
Vacuum Speed Selector	-	-	•



**Safety**

Driving LED Light Pack Kit (Front)	○	○	•
Emergency Stop	•	•	•
Electro Parking Brake	•	•	•



**Environment**

TDC - Trident Dosing Control	○	○	○
TES - Trident Energy Saver	•	•	•
TFC - Trident Flow Control	-	-	•



**Dealer-Installed Optional Equipment**

Dealer-Installed Optional Equipment	T20SC Pro	T20SC Pro - Orbital	T26SC Plus
Trident Dosing Control Kit	HIL227201	HIL227201	HIL227201
Hillyard Fleet Management Kit	HIL227715	HIL227715	HIL227715



Better Built. Better Equipment.

## Power Options

### Maintenance Free



- The ultimate solution for simplicity and durability.
- Virtually maintenance free. Just plug in the charger when not in use.
- Full replacement three-year warranty with use of the included Protection from Overdischarge (POD) device.



### Flooded Lead Acid



- Conventional deep-cycle battery for cleaning equipment.
- High quality, lower-cost alternative to maintenance-free batteries.
- Requires routine maintenance to maintain electrolyte levels and warranty. Pro-rated one-year warranty.



## Battery Charger - Lester Summit Series II



Full replacement 3-year warranty



### BLUETOOTH®

Featuring Bluetooth wireless communication with apps for Apple® and Android® phones and tablets. View charge cycle status, select the active battery profile, upload new profiles, change between on-board and off-board and download charge history records anytime using just a smart phone or tablet.



### PERFORMANCE

Our Summit Series® II provides industry leading charging performance and intelligence. Our proprietary Progressive DV/DT charge algorithm ensures a precisely charged battery every time. The chargers are tested in extreme temperatures and operating conditions and built to last.



### EFFICIENCY

Our switch mode (high frequency) chargers have best-in-class efficiency and are compliant with the latest DOE and CEC standards. We operate a CEC approved laboratory in our Lincoln, NE manufacturing plant.



Specifications		T20SC Pro	T20SC Pro - Orbital	T26SC Plus
Hillyard Item Number		HIL56005	HIL56006	HIL56007
Cleaning Path	In	20	20	26
Squeegee Width	In	28	28	31
Disc Brushes	(No.) In	(1) 20	n/a	(2) 13
Rectangular Pad	In	n/a	(1) 14 x 20	n/a
Oscillations Per Minute	(No.)	n/a	2400	n/a
Solution Tank	Gal	15.9	15.9	15.9
Recovery Tank	Gal	17.2	17.2	17.2
Supply/Traction	V	24/Automatic	24/Automatic	24/Automatic
Acoustic Level (Iso 11201)	Db (A)	<70	<70	<70
Brush Motor(s)	(No.) V/W	(1) 24/500	(1) 24/560	(2) 24/400
Vacuum Motor	V/W	24/410	24/410	24/410
Traction Motor	V/W	24/180	24/180	24/180
Brushes RPM	RPM/Min.	140	n/a	140
Brush Pressure - Variable Range	Lb	55-77	55-77	55-77-99
Forward Speed	MPH	0 - 1.86	0 - 2.17	0 - 2.17
Gradeability	%	10	10	10
Productivity	Sq.ft/Hr	19,000	19,000	19,000
Battery Compartment Dimensions (L,H,W)	In	19.0, 10.0, 13.8	19.0, 10.0, 13.8	19.0, 10.0, 13.8
Machine Dimensions (L,H,W)	In	51.0, 48.0, 28.0	51.0, 48.0, 28.0	51.0, 48.0, 31.0
Machine Weight (Without Battery)	Lb	529	529	529
Contents		1 - Machine 1 - Nylon Brush 1 - Pad Holder 1 - Owners Kit	1 - Machine 1 - Charging Cord 1 - Owners Kit	1 - Machine 2 - Nylon Brushes 2 - Pad Holders 1 - Owners Kit

### ORDER WITH FACTORY INSTALLED BATTERIES

Equipment purchased with factory installed batteries include batteries, cables, and a shelf charger. TPPL machines are equipped with the required Protection From Overdischarge (POD) device.

Model	T20SC Pro		T20SC Pro - Orbital		T26SC Plus	
	HIL56005SLA	HIL56005WET	HIL56006SLA	HIL56006WET	HIL56007SLA	HIL56007WET
Hillyard Item Number	HIL56005SLA	HIL56005WET	HIL56006SLA	HIL56006WET	HIL56007SLA	HIL56007WET
Battery Type	Maintenance Free (TPPL)	Flooded Lead Acid	Maintenance Free (TPPL)	Flooded Lead Acid	Maintenance Free (TPPL)	Flooded Lead Acid
Quantity	2	2	2	2	2	2
Voltage / Capacity	12 V / 128 AH	6 V / 150 AH	12 V / 128 AH	6 V / 150 AH	12 V / 128 AH	6 V / 150 AH
Dimensions LxWxH (in)	13.5 x 7.3 x 11	13 x 7.2 x 11.2	13.5 x 7.3 x 11	13 x 7.2 x 11.2	13.5 x 7.3 x 11	13 x 7.2 x 11.2
Weight, Each (lbs)	95	85	95	85	95	85
Includes	Machine, batteries, cables, shelf charger, POD device	Machine, batteries, cables, shelf charger	Machine, batteries, cables, shelf charger, POD device	Machine, batteries, cables, shelf charger	Machine, batteries, cables, shelf charger, POD device	Machine, batteries, cables, shelf charger

Squeegee Replacement Guide	T20SC Pro	T20SC Pro - Orbital	T26SC Plus
Front And Rear Squeegee Kit	HIL227173	HIL227173	HIL228561

Brush and Pad Guide	T20SC Pro	T20SC Pro - Orbital	T26SC Plus
Brush(es) - Soft, 0.3MM PPL, Blue	HIL404654	n/a	HIL422189
Brush(es) - Medium, 0.6MM PPL, White (Standard)	HIL405631	n/a	HIL422971
Brush(es) - Stiff, 0.9MM PPL, Black	n/a	n/a	HIL422972
Brush(es) - Abrasive, 80 Grit, Gray	n/a	n/a	HIL422981
Pad - Red	HIL42220	HIL41420	HIL42213



PO Box 909  
St. Joseph, MO 64502  
www.hillyard.com  
LIT-T20SERIES\_FULL-0624

Subject to change without notice.