



# *Flow Xtreme*

## **Above Ground Pool Filter & Pump Manual**



## **CONGRATULATIONS!**

**YOU HAVE PURCHASED A HIGH QUALITY FlowXtreme FILTRATION SYSTEM FOR YOUR ABOVE GROUND POOL. YOUR NEW FILTER SYSTEM HAS BEEN MANUFACTURED AND TESTED TO OFFER MANY YEARS OF TROUBLE FREE SERVICE.**

### **IMPORTANT – READ THIS MANUAL CAREFULLY**

#### **A. Safety Warnings**

Read all Warnings and Cautions noted below. Failure to do so could result in serious or fatal injury.

- Prior to installation of this unit, carefully read and adhere to all CAUTION, ATTENTION, and ADVICE notices located throughout this manual. Failure to comply with these instructions can cause serious injury, death, or damage to the unit.
- RISK OF SUCTION ENTRAPMENT HAZARD, WHICH, IF NOT AVOIDED CAN RESULT IN SERIOUS INJURY OR DEATH. Do not block pump suction at the pump or in the pool as this can cause severe injury or death.
- Electrical wiring MUST be installed by trained professional. Adhere to local codes and regulations.
- Avoid electric shock. DO NOT USE power extension cords.
- Connect ONLY to a Ground-Fault Circuit Interrupter (GFCI) power outlet. Consult a qualified professional electrician for safe and proper installation of a qualified electrical outlet.
- Incorrectly installed equipment may fail, causing severe injuries or damage to the pump-filter system.
- Never allow the pump or filter tank to become submerged in water.
- Never place the pump or filter tank in your pool.
- Trapped air in the pump-filter system may cause the TANK COVER to be blown off which can result in death, serious injury, or damage to the pump-filter system. Ensure all air is out of system before operating.
- Never change the 7 Position Multi-Port Valve while the system is operating.
- ALWAYS unplug the system before changing positions the control valve.
- Install this product with sufficient safety margin from the pool to prevent children from using the system to access the pool.
- Never PLUG or UNPLUG this unit from an electrical source while standing in water.
- NEVER service this unit with electrical power cord connected.
- DO NOT operate the system while the pool is being used.
- KEEP CHILDREN AWAY from all electrical equipment.
- NEVER ALLOW CHILDREN TO OPERATE THIS EQUIPMENT.
- The Pool Owner should always exercise caution and common sense when utilizing their swimming pool and operating equipment.

## **B. General Information**

This manual provides information relating to the installation, utilization and maintenance of our filtration system. We recommend that you read this manual in its entirety and keep it for future reference,

The pump included with the filtration system is a horizontal, self-priming centrifugal pump. For the pump to function correctly, the water temperature must not exceed 35°C/95°F. The materials used in the pump have undergone stringent hydraulic testing and electrical inspections.

The filter tank included in the filtration system consists of high-grade polypropylene (PP). It is manufactured as a single unit (absolutely corrosion resistant and resistant to commercially available swimming pool chemicals). (Prerequisite: Compliance with the standard recommended specifications for the pH- and chlorine value). It is equipped with a tank drainage system, pressure gauge, built-in container components, e.g. bottom laterals for even water distribution. The filter tank comes ready to attach and is supplied with a user-friendly 7 Position Multi-Port Valve attached to the tank cover, an approved filter pump with hair and lint basket, and a plastic base for ready on- site mounting.

Read this manual carefully before installation. The filtration system and pump must be installed in accordance with all federal and local codes and standards in effect for the area of installation.

We decline all responsibility for the consequences of failure to comply with the installation instructions. We recommend that you comply with the power source instructions to avoid overloading the pump motor and/or causing electric shock.

This filtration system is not intended for use by persons with reduced physical, sensory or mental capabilities, or lack of experience and knowledge.

Safety notes and information boxes should always be observed.

## **C. Safety Notes**

Your filter pump was constructed and tested and left the manufacturing plant in technically operational condition. In order to maintain this condition and ensure safe operation, the user should observe the notes and product information contained in this technical manual. If there is any indication that safe operation is no longer possible, the device is to be disconnected from the power supply and secured against accidental use.

This is the case when:

- The device has visible damage.
- The device no longer appears functional.
- After long periods of storage in poor conditions.

If the power cord or other parts of this equipment are damaged, they have to be replaced by the manufacturer, its service agent or a similarly qualified person in order to avoid danger.

## **D. Damage during delivery**

Your filter system has been carefully and professionally packed for delivery. Please check to ensure that the package is undamaged and that all parts are in the box. If you purchased this product on order and the product was shipped to you, ensure that delivery is complete. Damage to product as a result of shipping is not the responsibility of the supplier and must be immediately reported to the shipper. The shipper assumes the liability for damages during delivery, the supplier is not responsible.

## **E. Implied Warranty**

The manufacturer warranties safe operation and reliability only under the following conditions:

- The filter system is installed and operated according to the assembly and operating instructions.
- Only original replacement parts are used for repairs or replacements (consumable & expendable parts do not fall under the warranty).

Expendable parts that do not fall under the warranty include:

- All O-rings
- Pressure gauge
- Mechanical seal, complete
- Hoses and metal hose clamps

## F. Resultant Damages

We cannot be responsible for damages to the product if the product is not used in accordance with the instructions provided.

## G. Technical Data and Specifications

- The recommended filter run time is twice a day for 4 to 5 hours; regular backwashing time is 2-3 minutes at least once a week, and floor vacuum cleaning as needed are the basic pump requirement for maintaining clean swimming pool water!
- The major components for this models are: (Confirm you have all these components before starting installation)

**The 7-way valve, filter pump, filter tank, 1 1/4"-1 1/2" hose connectors, hose to connect the pump to the valve and a base plate with mounting hardware.**

<b>Model</b>	<b>NE4486 (200-Conde 8)</b>
<b>Flow rate:</b>	<b>1850 GPH</b>
<b>Max Operating Pressure</b>	<b>22 psi</b>
<b>Voltage/Frequency:</b>	<b>110V/60Hz</b>
<b>Power</b>	<b>1/3 HP</b>
<b>Amount of Sand:</b>	<b>Max. 22lbs</b>
<b>Pool size:</b>	<b>Max. 5000 US Gallons</b>

## H. Unpacking your filter system

Carefully remove the product and all component parts from the box. Cross reference all parts in the box with the parts list reference chart to make certain all parts are present before beginning assembly.

NOTE: Some parts may be located within the filter tank. To access these parts, you must remove the tank cover. Refer to \*page10-12 for complete EXPLODED VIEW PARTS DIAGRAMS.

## I. Power source instructions

1. The Above Ground filter pump system you have purchased is equipped with a standard electrical cord and plug which should only be connected to a power outlet protected by a 30 Amp Ground-Fault-Circuit-Interrupter (GFCI) that has been installed by a professional electrician and adheres to local codes and regulations.
2. To avoid electric shock, power cord extensions should not be used.

3. Electrical installations for In Ground Systems should be carried out by a licensed local electrician and follow all the applicable national and local specifications and codes for swimming pool construction.

## **J. Positioning your filter system**

- For the operation of this filter system with Above Ground pools, you need a skimmer installed in your pool. Either an integrated skimmer (built into the pool wall) or a suspended skimmer (attachment to the pool wall).
- The installation area must allow an adequate safety margin to the pool wall.
- We recommend putting the filter system on a concrete slab or similar. Be sure the installation is level.
- Additional installation accessories such as hoses, hoses clamps, and filter sand (not included) are available from your pool dealer.

## **K. Filter-Pump Assembly (Figure1)**

### 1. Filter pump & Base Plate assembly

Secure filter pump to the base plate with the provided pump mounting hardware. Orient as shown.

### 2. The filter pump consists of the following components:

- a. Pump body
- b. 7 position valve
- c. Internal Seal (O-Ring) seal
- d. Valve plate clamping ring with bolt & nut
- e. Filter tank
- f. Riser pipe and under drain assembly
- g. Filter laterals
- h. Drain plug assembly
- i. Centering plate & Sand guard
- j. Base plate
- k. 1.5" Pressure hose

### 3. Filter Tank assembly

- a. The riser pipe with conical under drain assembly is inserted into the tank (Figure 2&3).
- b. Install the tank drain assembly as shown in figure 1
- c. Make sure that the riser pipe and under drain assembly are seated on the bottom of the tank.
- d. Put the centering plate sand guard on the tank opening, while centering the riser pipe. (Figure 4)
- e. Fill the filter tank to about 1/8 depth with water then up to 3/4 full with #20 Pool Filter Grade silica sand. (Figure 4)

NOTE: Installation of sand other than #20 Pool Filter Grade silica sand will NOT function properly, and may void your warranty.

Cotton Tails filter media can be substituted for #20 Pool Filter Grade silica sand. Follow Cotton Tails installation and use instructions.

- f. Attach the 7 position valve to the Tank opening using the thick O-ring and the clamping ring (Figure 1, 5&6). Before you do this, clean tank opening to wash off any sand or accumulated debris. The clamping ring is connected with the clamping ring bolt and nut (Figures 5 & 6).
- g. The pressure gauge (if included) is screwed to the side of the 7 position valve. Seal with Teflon tape. The pre-installed vent plug must be removed first (Figure 9).

h. Attach the pump fittings to the 7 position valve. Seal the pump fittings sufficiently with Teflon tape, available at any plumbing or hardware store.

#### 4. Pump Hose Connections (Figure 7)

- a. Skimmers: Connect hose from pool skimmer to the intake fitting on the front of the pump.
- b. Pressure line: Connect the flexible corrugated hose from the upper discharge point on the top of the filter pump to the connector with designation “PUMP” on the 7-way valve. Use stainless steel hose clamps to secure both ends of the hose.
- c. Return line: Connect flexible hose from the 7-way valve port with the designation “RETURN” to the connection for the pool skimmer. Secure all connections with hose clamps.
- d. Backwash: Connect to “WASTE” using backwash hoses and clamps. Backwash hose, clamps are available from your local swimming pool retail professional.

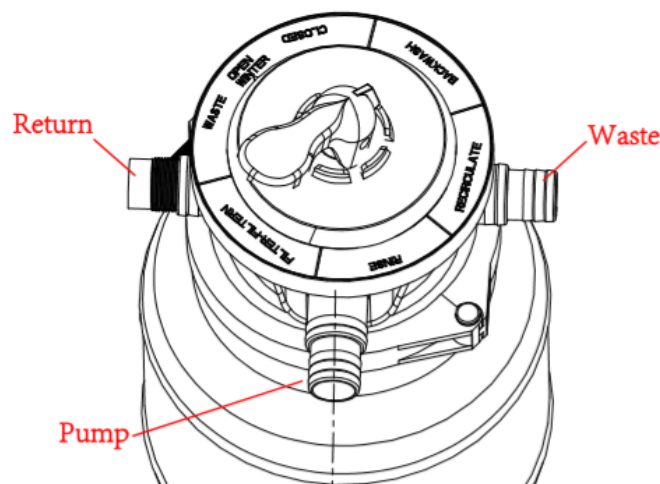

## L. Filter system start up

Once the filter system has been properly assembled, the tank filled with #20 Pool Filter Grade silica sand or Cotton Tails and the hoses connected as described, you may begin filtration. If using Cotton Tails for the filtration media, follow the instructions received with the Cotton Tails. However, we recommend that you first clean and prepare the new sand. Cleaning the sand prior to filtering your pool will remove most of the dust and tiny sand particles that may exist in the sand. If you move straight to filtering, these particles will end up in your pool. To clean the sand, please follow the instructions below using filter position #5, Backwash.

Do not turn on the system until advised to do so.

Note: If using Cotton Tails instead of sand do not back wash on initial installation. Follow the use instructions provided with Cotton Tails.

### 1. Cleaning the sand for Above Ground Pools

The swimming pool must be filled with water, according to your pool dealer’s instructions. The water must flow down towards the filter pump. Slightly open the clear strainer basket cover lid until water flows out from the strainer basket top (transparent cover with screw connection on the top of the filter pump).

Release the shut off valve at the intake port (Skimmer) in the pool. If you plugged the intake port (Skimmer), remove the plug to allow the water to flow into the intake hose.

With the filter-pump system installed in a level location lower than your pool’s water level water will automatically flow into the pump-filter system. Allow the filter tank to fill with water. Check for leaks and

make any necessary adjustments to stop any leaks found.

It may be necessary to use “Teflon” tape, available at any plumbing or hardware store, wrapped around the hose fittings threads, in order to stop leaks.

2. Start with the multi-position valve in position #5, Closed.

3. Follow the backwash process described below to remove small sand particles and debris from the sand bed :

- Turn off the Motor/Pump at the Power Source.
- Attach backwash hose (not included) to backwash port.
- Place the Multi-Port Valve in the “4 – Backwash” position.
- Turn on the Pump
- Run filter in BACKWASH mode until discharge water is clear.
- Turn off the Motor/Pump at the Power Source.
- Place the Multi-Port Valve in the “2 – RINSE” position.
- Turn on the Pump.
- Allow filter to run for 60 seconds to remove any remaining sand or debris residue from pump and valve.
- Turn off the Pump at the Power Source.
- Place the Multi-Port Valve in the “1 – Filtration” position.
- Turn on the Pump.
- Your filtration system is running and ready for further operation.

### M. Filter Valve Position Operation

Setting	Complete water flow/function
Filter Position 1	<u>Function:</u> Regular pool filter action & vacuuming. This is the setting the filter will be set to most of the time. In this position, water is directed through the top of the filter where it compresses and flattens down the sand. Contaminations are trapped by the sand as water makes it way to the bottom strainer, out of the filter and back to the pool.
Rinse Position 2	<u>Function:</u> Use after backwashing to clean the filter bed. This should always be done immediately after backwashing, new sand addition or filter start-up. In this position, water is directed to the top of the tank where it flushes the valve while sending water out the waste line.
Circulation Position 3	<u>Function:</u> Circulate water after chemical treatment. This position is used during certain pool cleanups and chemical treatments when you don’t want the water contaminating the sand. In this position, water is only directed through the valve back to the pool and does not filter through the sand.
Backwash Position 4	<u>Function:</u> Clean filter of captured debris. This is the position needed to clean the filter & the sand. You’ll know it is time to backwash when the pressure gauge shows more than 10 PSI above what it normally reads when the filter is clean. In this position, water is directed through the bottom strainer, reversing the flow through the tank. This causes the sand to separate and lift while releasing trapped debris out the waste port and backwash hose.

Closed Position 5	<u>Function:</u> Cleaning the hair and lint strainer. This position stops the flow of water into the pump and filter. CAUTION: Do not run pump with valve in this position.
Purge/Drain Position 6	<u>Function:</u> Bypass the filter. This position is ideal for vacuuming pools with large amounts of debris or after an algae treatment. In this position, water bypassed the filter and sends all the water and contaminants out the waste line.
Winterize Position 7	<u>Function:</u> Winterizing and storage. In this position, the valve lever is between positions which removes pressure from internal valve components for winter (off-season) storage. CAUTION: Do not run pump with valve in this position.

## N. Manual Vacuuming an Above Ground Pool

Vacuuming is done in valve position #1, Filter, on the valve. The pool vacuum is connected by use of a pool vacuum hose and vacuum plate directly into the skimmer. Do not turn on the pump until the pool vacuum is connected and ready for operation.

Important: The pool vacuum hose must be fully filled with water so that the pump does not lose prime, run dry and fill the tank with air.

## P. Winterize the system in cold weather climates

### 1. For Above Ground Pools

- Unplug the pump from the power source.
- Close the shut off valves or block the flow of water at the pool inlet and return ports.
- Disconnect the filtration system from the pool, drain the tank and hoses.
- Place the handle on the central valve in position 7- 'Winterize' to relieve the tension on the spring and internal valve components. This will prevent the diverter gasket from potentially sticking to the diverter valve seat and tearing at start up the next season. This would not be covered under warranty.
- Store the filter system in a location protected from frost and severely cold temperatures. In a garage or insulated storage shed is recommended

## Q. Important Do's & Don'ts

### DO'S:

- Be aware and make note of the filter pressure when the sand is clean. Backwash when you see an increase of 10 PSI on the pressure gauge.
- Backwash long enough to clean the sand bed. Let the system backwash until the water leaving the waste line is clear. Note that backwashing can remove 50 – 300 gal of water from your pool so pay attention. Also, be aware of local codes regarding pool water disposal as some communities have rules or codes regarding pool water drainage.
- Protect bottom strainer while replacing or adding sand. Fill the tank with 8" – 12" (about 1/8 of tank height) of water. Cover the water chamber to avoid getting sand inside the riser pipe and laterals under drain assembly.



- Start filter in Backwash mode for about 3 minutes and then for about 1 minute in the rinse mode before initial startup or after adding new sand. By doing this you can avoid blowing small particles and impurities from the new sand into your pool. If some debris from new sand does go into your pool, vacuum it with the system in purge mode, otherwise you may send it back to the pool.

**DON'TS:**

- Move valve handle while the pump is running. It will damage the valve and possibly other equipment as well. Damage caused by repeatedly moving the valve handle while the pump is running will NOT be covered under warranty.
- Backwash excessively. Sand filters operate more efficiently during mid-cycle. Some level of debris in the sand bed actually helps filtration and makes the filter more effective. Too much backwashing will reduce efficiency.
- Vacuum the pool in backwash mode. You can plug up the strainer at the bottom of the filter which will result in inefficient operation. Plus you may have to remove all of the sand to get it unclogged. Damage caused by this action will NOT be covered under warranty.
- Let filtration system run dry (without water)! If your pump runs dry too long damage to the pump may occur. Damage to the pump caused by dry running will NOT be covered by the warranty.

**R. Trouble Shooting – See additional Pump Trouble shooting information located after the System technical information.**

Malfunction	Cause	Solution
Pressure gauge has reading more than 10 PSI over the normal filtering pressure	Dirty filter bed	Backwash the filter (position 4)
Pressure is too low	Hair and lint strainer basket is dirty; Pump gets too little water	Clean the hair and lint strainer; check the suction line and the water level
Air in the pump	Poor seal on the intake side of pump	Tighten hose clamps and connecting fittings
Leaking filter	Seal Defective	Check the seal, replace if needed
Pump does not run	Not plugged in	Check the socket and power cord
	G.F.C.I./ or main circuit breaker tripped	Switch on the breaker (if it is immediately tripped again, there is a defect in pump or controls)
	Pump motor defective	Replace motor or entire pump
Sand in Pool	If the sand is newly replaced, the undersized grains are still present	Backwash several times until the backwash water is clear (position 4)
	Sand in Central Valve (from backwash)	Purge into drainpipe for 30 seconds (position 6)
	Filter bottom strainer is damaged	Replace the filter bottom strainer

Air in system	This is normal and will occur occasionally	Loosen, but do not re-move, the air relief valve plug on the multi-position valve to allow any trapped air to escape. Tighten the valve plug once all of the air has escaped.
---------------	--	---

## S. Installation and Operation Illustration Figures

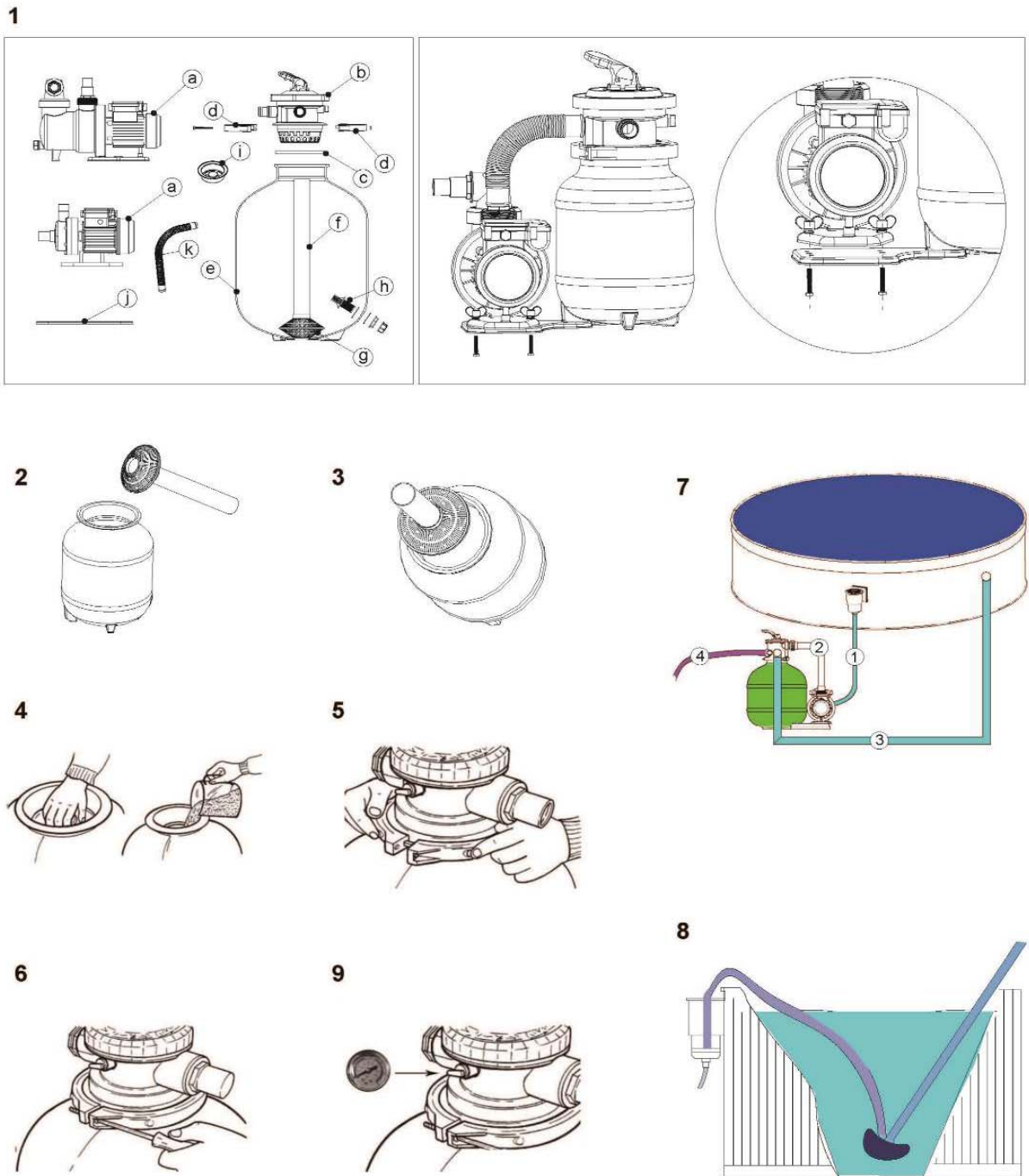

**T. FlowXtreme NE4486 WITH 1/3HP PUMP PARTS BREAKDOWN-CONDE 8**

Key	Part Name	Qty	Manf.No.	B.W..No.	For Model#
1	7-Way Valve	1	2001	NEP4051	NE4486
2	O-Ring	1	2002	NEP4052	NE4486
	Cap	1	2003	NEP4053	NE4486
3	Screw	1	3013	NEP4070	NE4486
	Nuts & Washer	1	3014	NEP4071	NE4486
	Washer	1	3015	NEP4072	NE4486
	Clamp Pin	1	3016	NEP4073	NE4486
	Right Clamp	1	3017	NEP4074	NE4486
	Left Clamp	1	3018	NEP4075	NE4486
4	Valve Big O-Ring	1	2004	NEP4054	NE4486
5	200-Blow Moulded Tank	1	2005	NEP4055	NE4486
6	Short Pipe	1	2006	NEP4056	NE4486
7	Basket Filter	1	2007	NEP4057	NE4486
8	Drain Valve	1	3021	NEP4077	NE4486
9	Base Plate	1	2009	NEP4058	NE4486
10	Soft Hose	1	2010	NEP4059	NE4486
11	Hose Clamp	2	3012	NEP4069	NE4486
12	Sand Funnel	1	3010	NEP4068	NE4486
13	Water Pump	1	SPS1A250	NEP4268	NE4486
14	Pump Bolt Wing Nut Pump Mounting Hardware	2	P00175	NEP4261	NE4486
	Pump Bolt Flat Water Pump Mounting Hardware	2	P00176	NEP4262	NE4486
	Pump Bolt Lock Washer Pump Mounting Hardware	2	P00177	NEP4263	NE4486
	Pump Bolt Nut Pump Mounting Hardware	2	P00178	NEP4264	NE4486

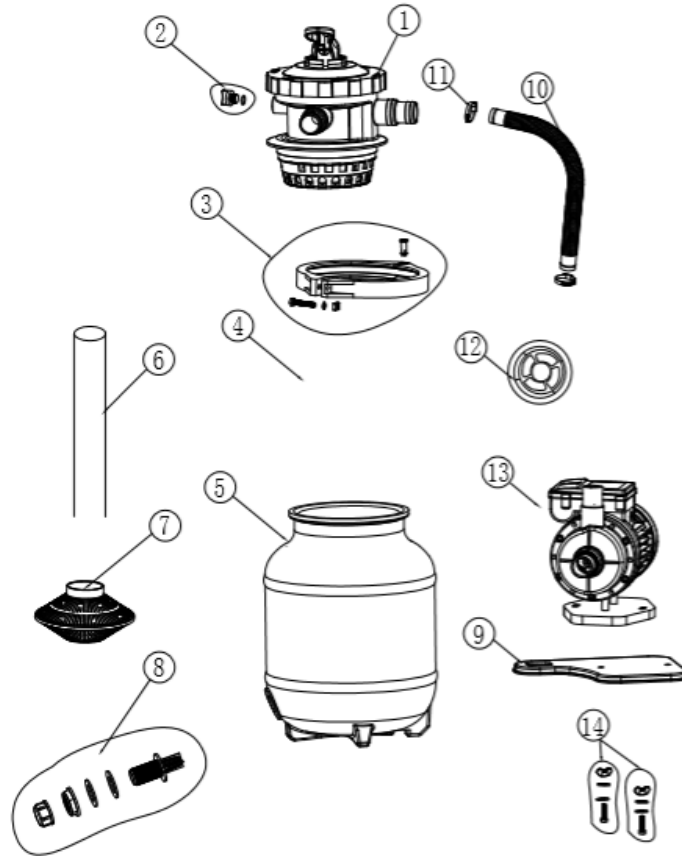

## U. TECHNICAL DATA for FlowXtreme Prime Single Speed Pumps

Model #s; NE4523, NEP4268, NEP4269

### Technical Data

Model	HP	Voltage	Hertz	Amps	Flow Rate GPM
NE4523	0.75	115	60	5.5	38GPM
NEP4268	0.33	115	60	2.5	24GPM
NEP4269	0.50	115	60	4.5	35GPM

### FlowXtreme PRIME, SPS1 Pumps Parts Breakdown & Diagram

Key	Part Name	Qty	Mnfg. No.	B.W. No.	For Model#
1	Water Pump/ Motor 250 W	1	SPS1A250	NEP4268	NEP4268
1	Water Pump/ Motor 450 W	1	SPS1A450	NEP4269	NEP4269
1	Water Pump/ Motor 550 W	1	SPS1A550	NE4523	NE4523
2	Transparent Hair & Lint Strainer Cover	1	P00131	NEP4245	NEP4268/NEP4269/NE4523
3	1 1/4"- 1 1/2" Hose Connector	2	P00132	NEP4246	NEP4268/NEP4269/NE4523

4	O-ring "A"- 2 1/4"	1	P00182	NEP4265	NEP4268/NEP4269/NE4523
5	O-ring "B"- 3"	1	P00183	NEP4266	NEP4268/NEP4269/NE4523
6	O-ring "C"- 1.5"	1	P00184	NEP4267	NEP4268/NEP4269/NE4523
7	Strainer Collar	1	P00133	NEP4247	NEP4268/NEP4269/NE4523
8	Strainer Basket	1	P00134	NEP4248	NEP4268/NEP4269/NE4523
9	Pump Drain Cap	1	P00135	NEP4249	NEP4268/NEP4269/NE4523
10	Drain Valve O-ring	1	P00136	NEP4250	NEP4268/NEP4269/NE4523
11	Motor Pump Seal - 250	1	P00137	NEP4251	NEP4268/NEP4269/NE4523
11	Motor Pump Seal - 450	1	P00138	NEP4252	NEP4268/NEP4269/NE4523
11	Motor Pump Seal - 550	1	P00138	NEP4252	NEP4268/NEP4269/NE4523
12	Impeller Assembly - 250	1	P001392	NEP4253	NEP4268
12	Impeller Assembly - 450	1	P001404	NEP4254	NEP4269
12	Impeller Assembly - 550	1	P001405	NEP20200	NE4523
13	Shaft Seal & Spring Assbly – 250	1	P00141	NEP4255	NEP4268/NEP4269/NE4523
13	Shaft Seal & Spring Assbly - 450	1	P00142	NEP4256	NEP4268/NEP4269/NE4523
13	Shaft Seal & Spring Assbly - 550	1	P00142	NEP4256	NEP4268/NEP4269/NE4523
14	Power Cord With 3 Prong Plug	1	P00143	NEP20201	NEP4268/NEP4269/NE4523

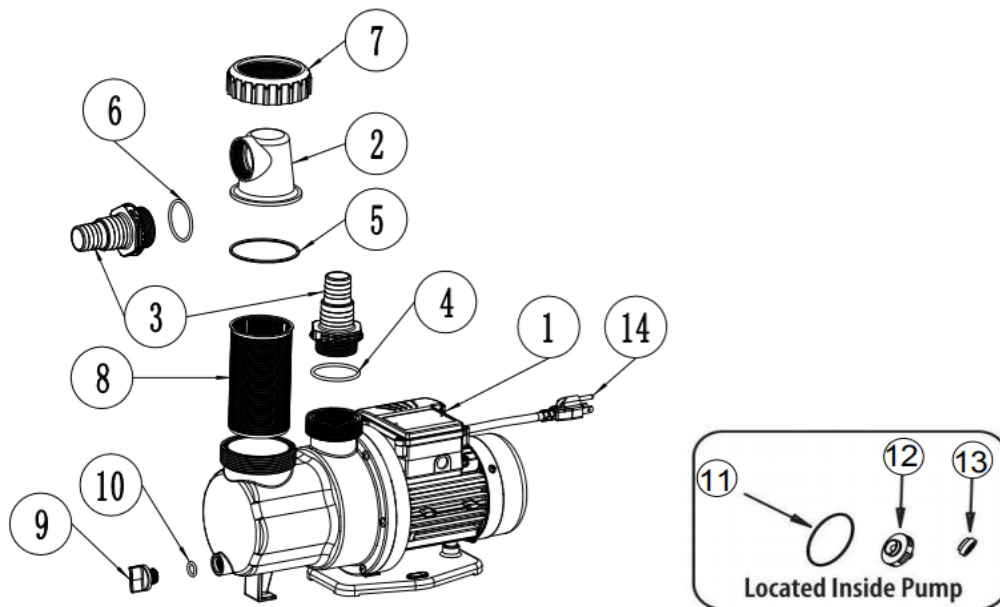

## V. Troubleshooting for and FlowXtreme Prime Pumps

### Motor Will NOT Start – Check For:

Make sure the terminal board connections agree with the wiring diagram on motor data plate label. Be sure motor is wired for available field supply voltage (see pump operating label).

1. Improper or loose wiring connections; open switches or relays; tripped circuit breakers, GFCI's, or blown fuses.

**Solution:** Check all connections, circuit breakers, and fuses. Reset tripped breakers or replace blown fuses.

2. Manually check rotation of motor shaft for free movement and lack of obstruction.
3. If you have a timer, be certain it is working properly. Bypass it if necessary.

### **Motor Shuts OFF – Check For:**

1. Low voltage at motor or power drop (frequently caused by undersized wiring or extension cord use).

**Solution:** Contact qualified professional to check that the wiring gauge is heavy enough.

2. Motor may be overheating due to direct sunlight or low water level in the pump basket.

**Solution:** Check water flow to insure uniform amount of water coming to the pump.

**NOTE -** Your pump motor is equipped with an “automatic thermal overload protector.” The motor will automatically shut off if power supply drops before heat damage can build up causing windings to burn out. The “thermal overload protector” will allow the motor to automatically restart once the motor has cooled. It will continue to shut off until the problem is corrected. **Be sure to correct cause of overheating.**

### **Motor Hums, But Does NOT Start – Check For:**

1. Impeller jammed with debris.

**Solution:** Have a qualified repair professional open the pump and remove the debris.

2. Motor is frozen either from months in the carton after manufacturing or from over winter storage.

**Solution:** Insert a flat bladed screw driver into the slot at the back end of the motor shaft and turn motor shaft until it moves freely. You may have to remove the protective metal cap from some models to access the motor shaft.

**NOTE –** All FlowXtreme & FX PRO II pumps are run tested with water before leaving the factory.

### **Pump Won't Prime - Check For:**

1. Empty pump/strainer housing

**Solution:** Make sure pump/strainer housing is filled with water and cover o-ring is clean. Ensure o-ring is properly seated in the cover o-ring groove. Ensure o-ring is lubricated and that strainer cover is locked firmly in position. Lubricant will help to create a tighter seal.

2. Loose connections on suction side.

**Solution:** Tighten pipe/union connections or hose clamps on flexible hose.

**NOTE -** Any self-priming pump will not prime if there are suction air leaks. Leaks will result in bubbles emanating from return fittings on In Ground pool wall.

3. Leaking O-ring on valves.

**Solution:** Tighten, repair, or replace valves.

4. Strainer basket or skimmer basket loaded with debris.

**Solution:** Remove strainer housing cover or skimmer cover, clean basket, and refill strainer housing with water. Tighten cover.

### **Low Flow – Generally, Check For:**

1. Clogged or restricted strainer or suction line.

**Solution:** Check for visible debris and remove if observed. If the problem continues contact a qualified repair professional.

2. Undersized pool plumbing.

**Solution:** Correct plumbing size.

3. Plugged or restricted discharge line of filter, valve partially closed (high gauge reading).

**Solution:** Sand filters – backwash as per manufacturer’s instructions; D.E. filters – backwash as per manufacturer’s instructions; Cartridge filters – clean or replace cartridge.

4. Air leak in suction (bubbles issuing from return fittings).

**Solution:** Re-tighten suction and discharge connections using Teflon tape. Inspect other plumbing connections and tighten as required.

5. Plugged, restricted, or damaged impeller.

**Solution:** Contact a qualified repair professional to install a new impeller & seal assembly.

### **Noisy Pump – Check For:**

1. Air leak in suction piping, cavitation caused by restricted or undersized suction line or leak at any joint, low water level in pool, and unrestricted discharge return lines.

**Solution:** Correct suction condition or tighten fittings, if practical. Holding hand over return fitting will sometimes prove this point or putting in a smaller return eyeball fitting.

2. Vibration due to improper mounting, etc.

**Solution:** Mount the pump on a level surface and secure the pump to the equipment pad.

3. Foreign matter in pump housing. Loose stones/debris hitting impeller will cause noise.

**Solution:** With the pump turned off or disconnected from the power source clean the pump housing and inspect to remove any debris visible in the inner portion of the pump by the impeller.

4. Motor bearings noisy from normal wear, rust, overheating, or concentration of chemicals causing seal damage. This will allow chlorinated water to seep into bearings wiping out the grease resulting in rusting of the motor shaft and causing the bearing to whine.

**Solution:** All seal leaks must be replaced at once. Have a qualified pump repair specialist replace the motor shaft seals and inspect the motor shaft for possible damage. If the motor shaft is damaged replace the motor.

### **Water Leaks Around Intake and Discharge fittings – Check For**

1. Lose union fittings or hose fittings.

**Solution:** Tighten fittings or remove, apply Teflon tape and reinstall.

2. Lose hose clamps on flexible hose.

**Solution:** Tighten hose clamps using a nut driver or wrench instead of a screwdriver

3. Leaks that continue after trying the above solutions.

**Solution:** Inspect union fittings and hose fittings for excess plastic mold flashing that can cause hoses and plumbing not to seal. If plastic mold flashing is found remove it with a fine tooth file or knife blade and re-assemble. If the fitting still will not seal replace them and reassemble plumbing with the new fittings.

## **ATTENTION**

**DO NOT RETURN THIS PRODUCT TO YOUR RETAILER. IF YOU ENCOUNTER ANY DIFFICULTIES WITH YOUR NEW SWIMMING POOL PUMP CONTACT BLUE WAVE CUSTOMER SERVICE FOR ASSISTANCE.**

**1-800-759-0977**

## W. Warranty Information

This product is warranted to the original purchaser to be free from defects in material or workmanship for a period of one (1) year from the date of the original retail purchase.

This warranty does not cover defects or damage due to improper installation, alteration, accident or any other event beyond the control of the manufacturer. Defects or damage resulting from misuse, abuse or negligence will void this warranty. This warranty does not cover scratching or damage that may result from normal usage.

This product is not intended for institutional or commercial use; the manufacturer does not assume any liability for such use. Institutional or commercial use will void this warranty.

This warranty is nontransferable and is expressly limited to the repair or replacement of the defective product. During the warranty period, the manufacturer shall repair or replace defective parts at no cost to the purchaser. Shipping charges and insurance are not covered and are the responsibility of the purchaser. Labor charges and related expenses for removal, installation or replacement of the product or components are not covered under this warranty.

The manufacturer reserves the right to make substitutions to warranty claims if parts are unavailable or obsolete.

The manufacturer shall not be liable for loss of use of the product or other consequential or incidental costs, expenses or damages incurred by the consumer of any other use. The user assumes all risk of injury resulting from the use of this product.

This warranty is expressly in lieu of all other warranties, expressed or implied, including warranties of merchantability or fitness for use to the extent permitted by Federal or state law. Neither the manufacturer nor any of its representatives assumes any other liability in connection with this product.

**All warranty claims must include the retailer's information where the product was originally purchased. A purchase receipt or other proof of date of purchase will be required to process all warranty claims. The model number and part numbers found within the assembly instructions will be required when submitting any parts requests or warranty claims.**

**For further warranty information or inquiries, please call 1 (800) 759-0977 Or email  
[warranty@splashnetxpress.com](mailto:warranty@splashnetxpress.com)**

**Blue Wave Products, Inc.  
1745 Wallace Ave, Suite B  
Saint Charles, IL 60174**



La garantie du produit est valide pour l'acheteur original en ce qui a trait aux pièces défectueuses ou à la main-d'œuvre pour une période de 1 année de la date d'achat.

Cette garantie n'est couverte pas les dommages causés par accident, par modification, par une installation défectueuse ou tout autre événement hors du contrôle du fabricant. Tout défaut ou dommage résultant de la négligence ou d'une mauvaise utilisation annule cette garantie. La présente garantie ne couvre pas les égratignures ou les dommages attribuables à un usage normal.

Ce produit n'est pas destiné à un usage institutionnel ou commercial; le fabricant décline toute responsabilité pour une telle utilisation. Un usage institutionnel ou commercial annule cette garantie.

Cette garantie est non transférable et est expressément limitée à la réparation ou au remplacement du produit défectueux. Au cours de la période de garantie, le fabricant s'engage à remplacer et à réparer les pièces défectueuses sans frais pour l'acheteur. Les frais d'assurance et d'expédition ne sont pas couverts et sont à la charge de l'acheteur. Les frais de main-d'œuvre et les dépenses liées au déplacement, à l'installation ou au remplacement du produit ou de ses composantes ne sont pas couverts par cette garantie. Le fabricant se réserve le droit de faire des substitutions de recours en garantie si la pièce n'est pas disponible ou obsolète.

Le fabricant décline toute responsabilité liée à la perte d'utilisation ainsi que tous les autres coûts directs ou indirects, frais ou dommages encourus par le consommateur qui aurait été causés par une autre utilisation.

L'utilisateur assume tous les risques de dommage résultant de l'utilisation de ce produit.

Cette garantie tient lieu expressément de toute autre garantie, exprimée ou implicite, y compris les garanties de qualité marchande ou d'adaptation à un emploi particulier dans la mesure permise par les lois fédérales ou provinciales. Ni le fabricant, ni aucun de ses représentants n'assument aucune autre responsabilité en rapport avec ce produit.

**Toute réclamation doit être faite par le détaillant où le produit a été acheté. Une facture ou autre preuve d'achat est nécessaire pour traiter toutes les réclamations de garantie. Le numéro de modèle et les numéros de référence figurant dans les instructions d'assemblage seront exigés lors de la soumission de demande de pièces ou de recours en garantie.**

**Pour plus d'information ou pour toute question, veuillez téléphoner au 1 (800) 759-0977 ou email [warranty@splashnetxpress.com](mailto:warranty@splashnetxpress.com)**

**Blue Wave Products, Inc.  
1745 Wallace Ave, Suite B  
Saint Charles, IL 60174**