

Installation Instructions

Touchless Soap Dispenser AC Power

Record your model number:

Noter le numéro de modèle:

Anote su número de modelo: _____

Français, page 24

Español, página 49

KOHLER®

Thank You for Choosing KOHLER

Need help? Contact our Customer Care Center.

- USA/Canada: 1-800-4KOHLER (1-800-456-4537)
- Mexico: 001-800-456-4537
- For service parts, visit kohler.com/serviceparts.
- For care and cleaning, visit kohler.com/clean.
- Patents: kohlercompany.com/patents

Warranty

This product is covered under the **KOHLER® Electronic Faucets, Valves, and Controls Five-Year Limited Warranty**, found at kohler.com/warranty. For a hardcopy of warranty terms, contact the Customer Care Center.

Tools and Materials

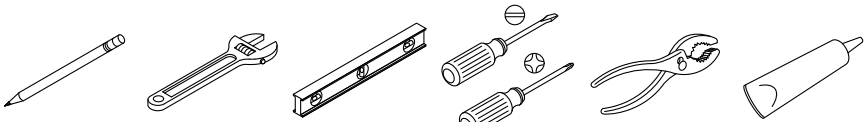

Sealant

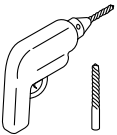

1/4"



1" to 1-1/4" Hole Bit

Plus:

- Foaming Hand Soap (1 cP – 100 cP)
- Single AC Supply SKU 13480-NA

- Multi-Outlet AC Supply SKU 13481-NA

Before You Begin



WARNING: When using electrical products, basic precautions should always be followed, including the following:



DANGER: Risk of electric shock. Connect only to a circuit protected by a Ground-Fault Circuit-Interrupter (GFCI)*.

*Outside North America, this may be known as a Residual Current Device (RCD).



WARNING: Risk of electric shock. Grounding is required. A qualified electrician should make all electrical connections.



WARNING: Risk of electric shock. Disconnect the power before servicing.



WARNING: Risk of injury or property damage. Read all instructions thoroughly before beginning installation.



CAUTION: Risk of product damage. This product contains sensitive electronic components. Do not store open containers of chemical or cleaning products near this product.

IMPORTANT! Your product may appear different than illustrated. The installation procedure is the same. Consult the specification sheet for rough-in dimensions for your model requirements.

Provide a constant unswitched 120 VAC electrical outlet located below the sink within 5' (1.5 m) of the control box.

Follow all local plumbing and electrical codes.

Soap Requirements



CAUTION: Risk of product damage. The foaming hand soap must have a dynamic viscosity rating between 1 centipoise – 100 centipoise (cP) measured in cP or grams/cm-s units. Soaps with a dynamic viscosity greater than 100 cP can cause premature wear and damage to the soap dispenser components and may void the product warranty.



CAUTION: Risk of product damage. Only use liquid foaming hand soap that contains no suspended particles or microbeads. Do not use nonfoaming liquid hand soaps, which typically have a dynamic viscosity rating of 1000 cP – 3500 cP.



CAUTION: Risk of product damage. Do not use alcohol-based soap and/or soaps with alcohol.

NOTE: KOHLER brand foaming hand soaps are precisely formulated to work with this product and have a dynamic viscosity rating of 1 cP – 20 cP.

NOTE: See kohler.com for more information on recommended foaming hand soaps. Precise information on soap material properties and dynamic viscosity rating can be found on the soap manufacturers published material safety data sheets.

Roughing-In

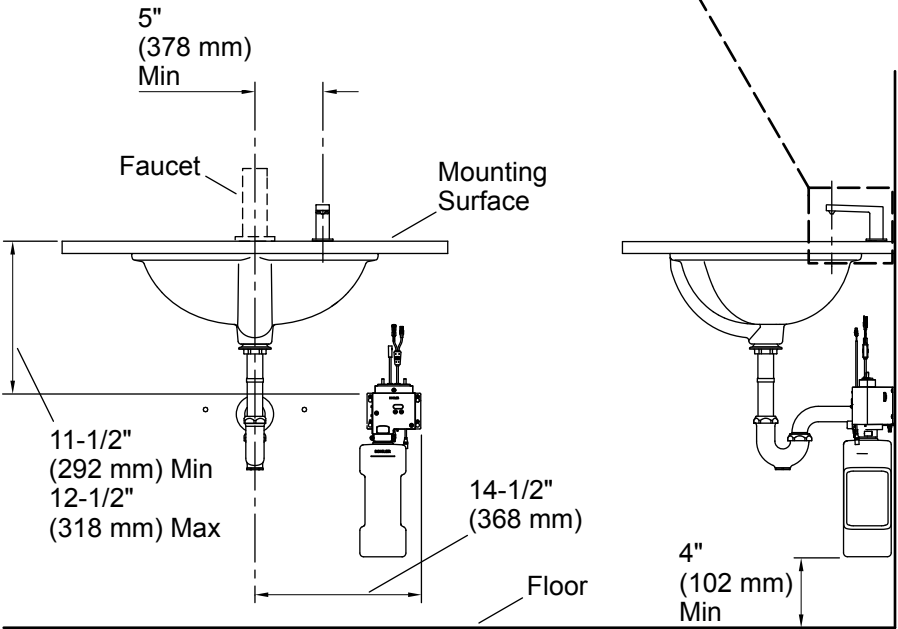
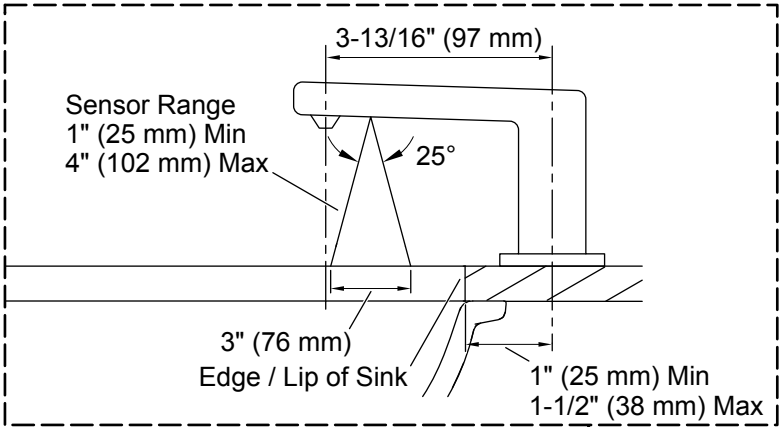

1. Install the Spout

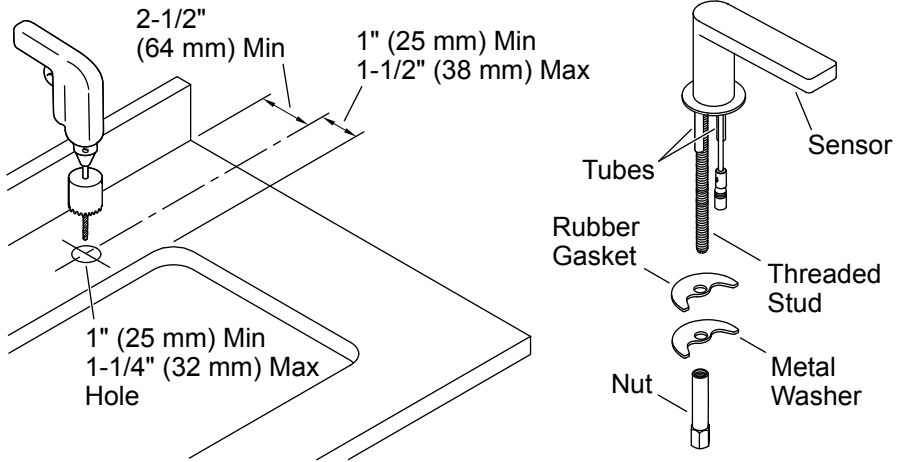

NOTE: The mounting hardware provided is for a standard deck thickness of 1/4" (6 mm) minimum to 2" (51 mm) maximum. For a larger deck thickness of 2" (51 mm) minimum to 4-1/2" (114 mm) maximum, order the deep roughing-in kit from kohler.com/serviceparts.

- Determine the mounting-hole location. Refer to the minimum and maximum dimensions shown above.
- Drill a hole through the mounting surface according to the surface manufacturer's instructions.
- Insert the spout with tubes and wires through the mounting hole.
- From under the sink, slide the rubber gasket and metal washer onto the stud.
- If desired, add sealant to the underside of the escutcheon. Wipe away excess sealant.
- Thread the nut onto the stud and wrench-tighten to secure the spout to the mounting surface.

2. Install the Control Box

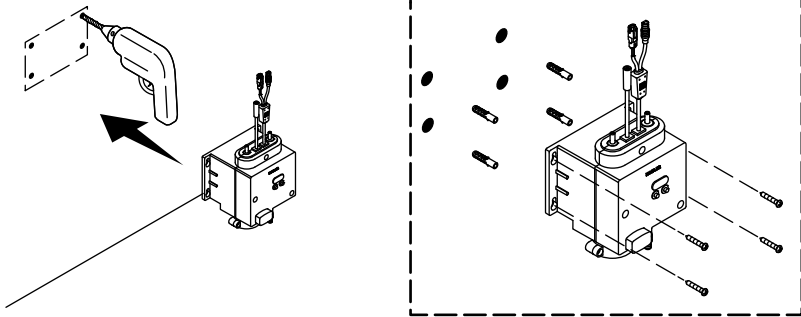

- Position the control box 11-1/2" (292 mm) minimum to 12-1/2" (318 mm) maximum below the deck. Check the Specification Sheet for the control box location.
- Mark the location of the mounting holes.

NOTE: The provided wall anchors are for concrete wall installation. Use the appropriate wall anchors for your wall material.

- Drill the holes per the anchor manufacturers instructions. If using the provided wall anchors, drill 1/4" (6 mm) pilot holes.
- Attach the control box to the wall as shown.
- Secure with the four screws provided.

3. Install the AC Single Supply

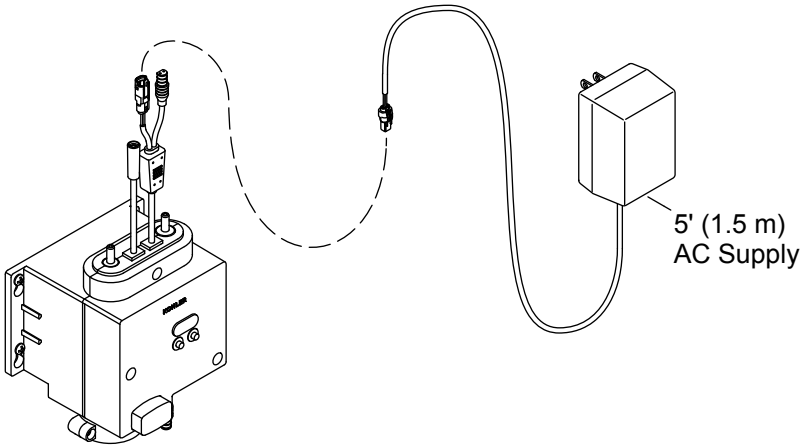

IMPORTANT! Follow the correct power system installation based on your model. For a multi-output AC supply power unit installation, refer to "Install AC Multi-Output Supply."

- Connect the power cord from the control box to the power cord from the Single AC Supply SKU 13480-NA. Maintain a drip loop when connecting.
- Plug the AC supply into an unswitched 120 VAC electrical outlet.
- Secure any excess wire under the deck.

4. Install the AC Multi-Output Supply

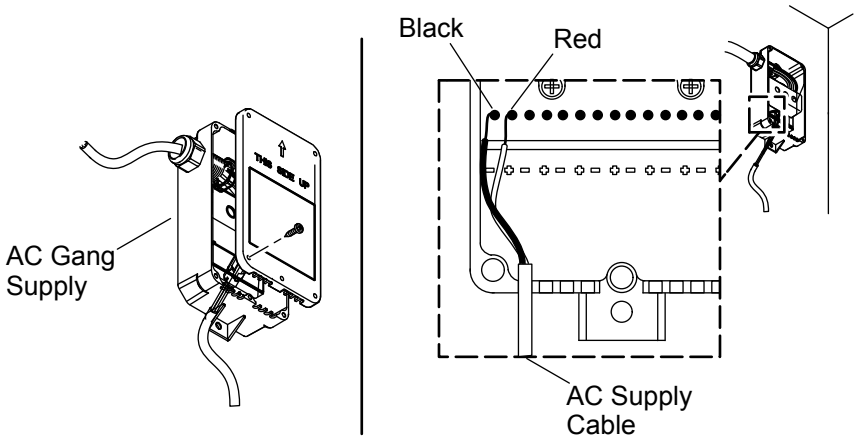

IMPORTANT! Follow the correct power system installation based on your model. For a single AC supply power unit installation, refer to Install the “AC Single Supply.”

IMPORTANT! Installation must not exceed two soap dispensers and two faucets on a multi-outlet supply.

- Mount the AC supply under the deck using the two screws provided. Orient as shown.
- Remove the cover.
- Connect the faucet wire to the faucet. Maintain a drip loop when connecting.
- If needed, cut and strip the AC supply wires to length.
- Connect the stripped ends to the bottom terminal block in the supply box.
- Secure the terminal box cover to the terminal box.

NOTE: AC supply cables are available in lengths of 4' (1.2 m), 6' (1.8 m), 8' (2.4 m), 10' (3 m) and 12' (3.6 m).

- Connect the power cord from the control box to the power cord from the Multi-outlet AC Power Supply SKU 13481-NA. Maintain a drip loop when connecting.
- Plug the AC supply into an unswitched 120 VAC electrical outlet.
- Secure any excess wire under the deck.

5. Connect the Control Box Wires

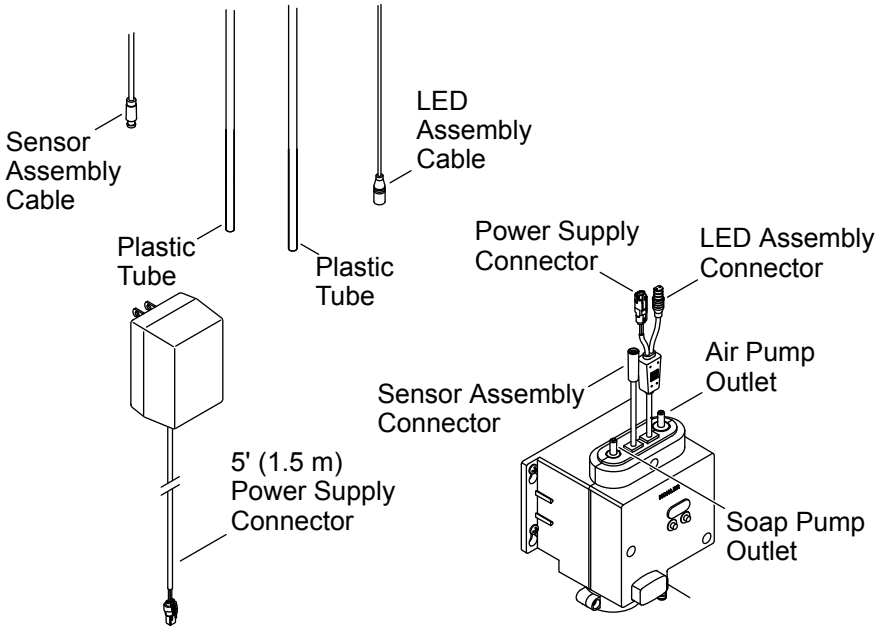

IMPORTANT! Verify that the cables are not pinched when connecting to the control box.

IMPORTANT! The area in front of the sensor must be free of objects during the 2 minute learning cycle or the soap dispenser may not function properly.

- Remove protective film from the sensor lens located behind spout nozzle.
- Connect the sensor assembly cable from the spout to the sensor assembly connector from the control box.
- Connect the LED assembly cable from the spout to the LED assembly connector from the control box.
- Connect the power supply connector from the battery box to the power supply connector from the control box.
- Allow 2 minutes for the sensor to cycle through the automatic sensing distance.

NOTE: Once the power supply cords are connected, the base of the soap dispenser will flash red twice every 6 seconds. This is normal and is a signal that there is no soap in the reservoir. After the soap is filled and primed, the flashing will stop.

- Secure any extra wire under the deck.

6. Connect the Tubes

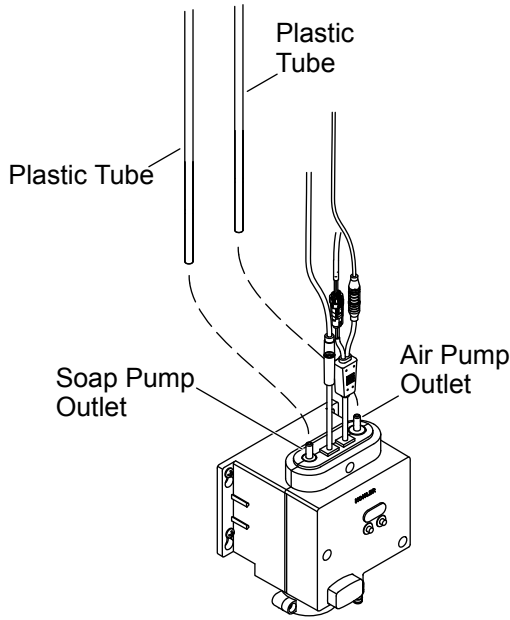

NOTE: The plastic tubes are interchangeable. Either tube can be connected to the soap or air pump outlet.

IMPORTANT! Verify that the tubes are not pinched when connecting the control box outlets. Do not coil extra tubing. The tubing should not hang below the outlet of the control box.

Soap Pump Connections

- Verify that the plastic tube from the spout is the appropriate length to reach the control box.
- The tube should not hang below the outlet of the control box. Cut the tube if necessary.
- Press the plastic tube onto the soap pump outlet on the control box until the tube stops.
- Verify that the tube is secure.

Air Pump Connections

- Verify that the plastic tube from the spout is the appropriate length to reach the control box.
- The tube should not hang below the outlet of the control box. Cut the tube if necessary.
- Press the remaining plastic tube onto the air pump outlet on the control box until the tube stops.
- Verify that the tube is secure.

7. Fill the Soap Reservoir

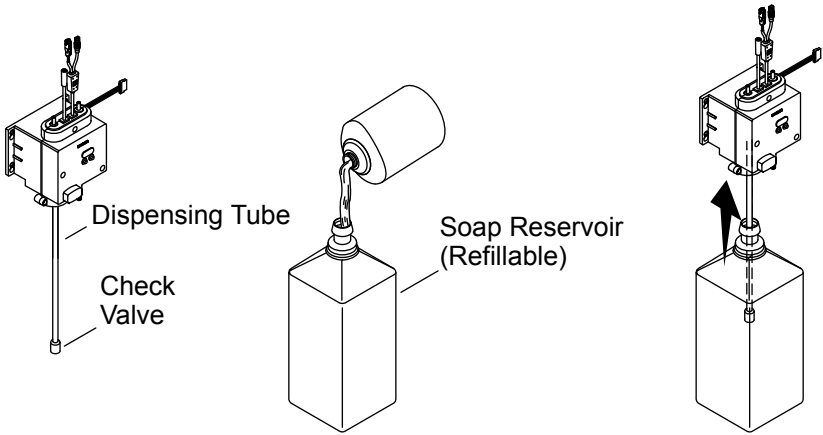

NOTE: The 1600 ml soap reservoir is included. Refer to kohler.com/serviceparts for the optional 800 ml soap reservoir.

- For 800 ml soap reservoir bottles, remove the check valve from the dispensing tube. Cut 2" (51 mm) from the dispensing tube so that the tube fits without any coiling. Reinstall the check valve.

NOTE: Refer to the "Soap Requirements" section for more information on the soap requirements for this product.

IMPORTANT! Rinse the empty soap reservoir with clean warm water before first use.

- Fill the soap reservoir with KOHLER brand foaming hand soap or foaming hand soap with 1cP – 100 cP to the "Max Fill" line. Do not overfill the soap reservoir.
- Insert the dispensing tube from the control unit into the soap reservoir.
- Press the soap reservoir into place until an audible click is heard.

8. Prepare the Soap Dispenser

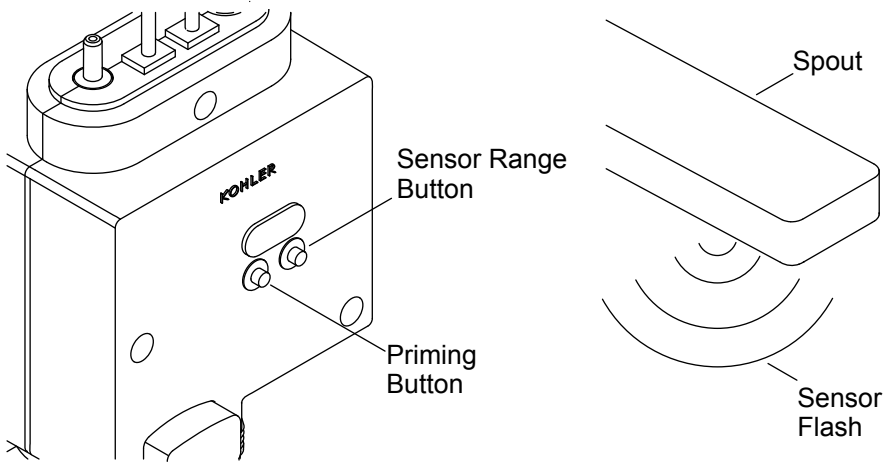

- Press the priming button located on the control unit until the soap streams from the spout nozzle – approximately 10 seconds.

9. Set the Volume of Soap Dispensed

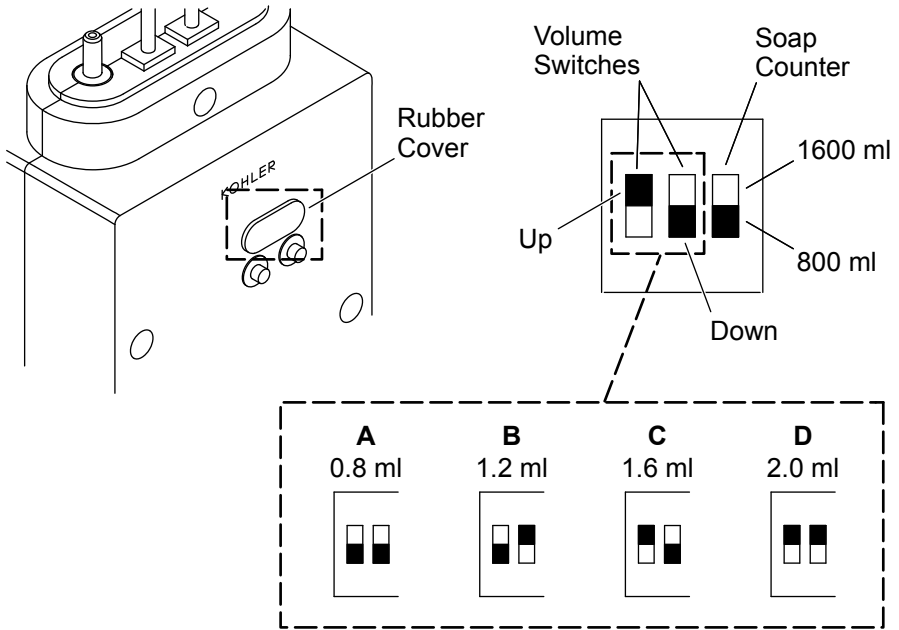

IMPORTANT! Four options are available to control the amount of dispensed soap. The desired option is set by moving the volume switches to an up or down position.

NOTE: The dispenser comes equipped with a 1600 ml reservoir, and the soap counter is set to the 1600 ml position. If an 800 ml reservoir is used, move the soap counter to the 800 ml position.

- Lift the rubber cover to access the control switches.
- Set the position of the two volume switches for the desired volume of soap dispensed. Refer to the settings shown above.
- Verify that the soap counter switch is set to the correct position for your reservoir size.
- Close the rubber cover.
- Refer to the chart below for the approximate number of dispenses available based on the volume setting and a full 800 ml or 1600 ml reservoir.

Setting	Soap Volume Dispensed	Soap Count (1600 ml)	Soap Count (800 ml)
A	0.8 ml	1800	900
B	1.2 ml	1200	600
C	1.6 ml	900	450
D	2.0 ml	720	360

10. Set the Sensor Range

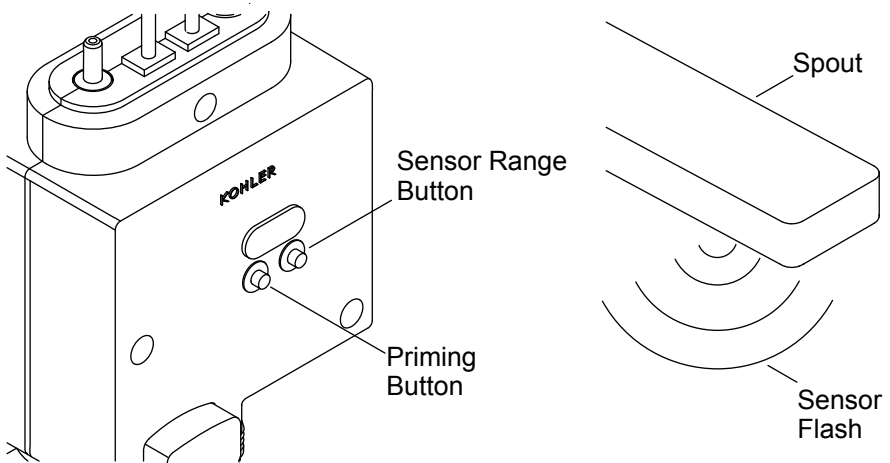

NOTE: The default sensor distance is 2-3/4" (70 mm) +/- 3/8" (10 mm).

- Press and hold the sensor range button for 2 seconds until the sensor flashes red.

NOTE: The sensor range is 1" (25 mm) – 4" (102 mm).

- Hold an object at the desired distance in front of the sensor until the red light stops flashing. This completes the sensor range adjustment.

Reset the Sensor Back to the Default Range

- Press and hold the sensor range button for 10 seconds until the sensor flashes red. Do not hold any object in front of the sensor until the red light stops flashing.
- This will reset the sensing distance of the soap dispenser to factory setting 2-3/4" (70 mm) +/- 3/8" (10 mm).

Spout LED Indicators

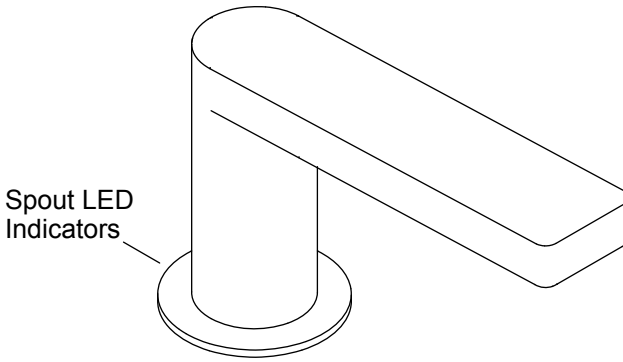

Flashing BLUE

The base of the soap dispenser will flash BLUE every 6 seconds when the voltage is lower than 4.8 Volts. The soap dispenser will continue to dispense soap.

The base of the soap dispenser will flash (twice) BLUE every 6 seconds when the voltage is lower than 4.5 Volts. The soap dispenser will not work. Replace the batteries.

Flashing RED

The base of the soap dispenser will flash RED every 6 seconds when the soap is running low. The soap dispenser will continue to dispense soap.

The base of the soap dispenser will flash (twice) RED every 6 seconds when the soap is empty. The soap dispenser will not dispense soap. Refill the soap reservoir and reprime the dispenser.

Care and Cleaning

Do not use any abrasive or harsh cleaners to clean the faucets.

For best results, keep the following in mind when caring for your KOHLER product:

Always test your cleaning solution on an inconspicuous area before applying to the entire surface. Visit kohler.com/clean for KOHLER brand faucet cleaner products.

Wipe surfaces clean and rinse completely with water immediately after applying cleaner. Rinse and dry any overspray that lands on nearby surfaces.

Do not allow cleaners to soak on surfaces.

Use a soft, dampened sponge or cloth. Never use an abrasive material such as a brush or scouring pad to clean surfaces.

Upon cleaning other areas of the restroom be sure the sensor lenses are protected from other cleaning chemicals/solvents to prevent potential damages to the sensor and/or electronics.

It is recommended to flush the system with warm water every 2 to 3 months.

- Remove and clean the nozzle foaming assembly with warm water.
- Remove and clean the check valve from the dispensing tube in the soap reservoir with warm water.
- Fill the soap reservoir with minimal amount of clean warm water.
- Reattach the soap reservoir to the control box. Press the system prime button. Hold the button down until all of the water has been flushed through the system.
- Refill the soap reservoir with the appropriate foaming hand soap. Press and hold the system prime button until all residual water is pushed through the pump and soap is dispensed.

Troubleshooting

This troubleshooting guide is for general aid only. For warranty service, contact your dealer, wholesale distributor, or call 1-800-4KOHLER.

Symptoms	Probable Cause	Recommended Action
1. A red LED light flashes at the base of the soap dispenser once every 6 seconds.	A. The soap is running low (70% of cycle used after priming).	A. Refill the soap reservoir with appropriate foaming hand soap. Prime the soap dispenser.
2. A red LED light flashes at the base of the soap dispenser twice every 6 seconds.	A. The soap is out or very low (90% of cycle used after priming).	A. Refill the soap reservoir with appropriate foaming hand soap. Prime the soap dispenser.
3. A blue LED light flashes at the base of the soap dispenser once every 6 seconds.	A. The batteries are running low (lower than 4.8 Volts).	A. Replace the batteries and prime the soap dispenser.
4. A blue LED light flashes at the base of the soap dispenser twice every 6 seconds.	A. The batteries are out of power (lower than 4.5 Volts).	A. Replace the batteries and prime the soap dispenser.

Symptoms	Probable Cause	Recommended Action
<p>5. No soap dispenses.</p>	<p>A. The sensor lens is dirty.</p> <p>B. The sensor assembly cable is disconnected.</p> <p>C. The tube (soap and air) is disconnected.</p> <p>D. No power supply or wrong connection.</p> <p>E. The soap pump is not primed after refilling.</p> <p>F. The dispensing tube/check valve is blocked.</p> <p>G. Object is within sensing range.</p>	<p>A. Wipe the sensor lens with a clean, dry, soft cloth.</p> <p>B. Reconnect the sensor assembly cable.</p> <p>C. Reconnect the tube to the control box.</p> <p>D. Check the power supply connection.</p> <p>E. Prime the pump.</p> <p>F. Clean the dispensing tube/check valve with warm water.</p> <p>G. Remove the object from the sensor range and wait 20 seconds before activating the soap dispenser.</p>
<p>6. The volume of soap dispensed is small or nonexistent.</p>	<p>A. The nozzle is clogged.</p> <p>B. The check valve is clogged.</p> <p>C. The soap pump is not working correctly.</p>	<p>A. Remove the soap nozzle and foaming assembly. Clean with warm water.</p> <p>B. Remove the check valve from dispensing tube. Clean with warm water.</p> <p>C. Order and install a new soap pump.</p>
<p>7. Only air bubbles are dispensing.</p>	<p>A. The soap pump outlet is clogged.</p> <p>B. The soap pump is leaking.</p>	<p>A. Remove the soap pump tubing. Clean the soap pump outlet with warm water.</p> <p>B. Order and install a new soap pump.</p>

Symptoms	Probable Cause	Recommended Action
8. No foam is dispensing. Only liquid soap is dispensing.	<p>A. The air pump is disconnected.</p> <p>B. The air pump/ tube is clogged.</p> <p>C. The air pump is not working.</p>	<p>A. Check the air pump connection and reconnect the tube to the control box.</p> <p>B. Remove the air pump tubing. Clean the air pump outlet with warm water.</p> <p>C. Order and install a new air pump.</p>

Compliance

This device complies with Part 15 of the FCC Rules. Operation is subject to the following two conditions: (1) this device may not cause harmful interference, and (2) this device must accept any interference received, including interference that may cause undesired operation.

Changes or modifications not expressly approved by the party responsible for compliance could void the user's authority to operate the equipment.

This equipment has been tested and found to comply with the limits for a Class B digital device, pursuant to Part 15 of the FCC Rules. These limits are designed to provide reasonable protection against harmful interference in a residential installation. This equipment generates, uses, and can radiate radio frequency energy and, if not installed and used in accordance with the instructions, may cause harmful interference to radio communications. However, there is no guarantee that interference will not occur in a particular installation. If this equipment does cause harmful interference to radio or television reception, which can be determined by turning the equipment off and on, the user is encouraged to try to correct the interference by one of the following measures:

- Reorient or relocate the receiving antenna.
- Increase the separation between the equipment and receiver.
- Connect the equipment into an outlet on a circuit different from that to which the receiver is connected.
- Consult the dealer or an experienced radio/TV technician for help.

This Class B digital apparatus complies with Canadian ICES-003.