



Project Name: _____

Location: _____

Item #: _____ Qty: _____

Model: _____

UNDERCOUNTER FREEZERS

MODEL: GRUCFZ-27 GRUCFZ-48



GRUCFZ-27



GRUCFZ-48

Grista's Undercounter Freezers are constructed of heavy duty stainless steel making them strong and durable enough to survive in any kitchen environment. These units are perfect for adding more storage space anywhere you need. The flat stainless steel countertop allows for them to be used as a separate workstation. All undercounter units come with 4" casters and plastic coated wire shelving. These models are ETL Listed and ETL Sanitation. They are backed with a 2 year warranty on parts and labor and a 5 year warranty on the compressor.

FEATURES AND CONSTRUCTION

- 430 series stainless steel exterior
- Painted aluminum interior
- Environmentally-friendly R290 refrigerant
- Precise digital temperature controller with LED display
- Foamed-in-place polyurethane high density cell insulation throughout the entire cabinet
- Automatic defrosting
- Removable door gasket
- Recessed door handles
- (4) 4" casters (2 locking and 2 non-locking)

ELECTRIC

115V / 60Hz / 1Ph
7' (2.1m) NEMA 5-15P cord set included

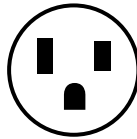

NEMA 5-15P

NOMINAL STORAGE CAPACITY

GRUCFZ-27 6.3 Cu Ft (178 L)

GRUCFZ-48 12 Cu Ft (340 L)

TEMPERATURE

Holding Temperature 33°F to 41°F (1°C to 5°C)

- These models are designed to operate in an environment where temperature and humidity do not exceed 75°F (24°C) and 55% relative humidity

3RD PARTY APPROVALS



Intertek



Intertek

GRISTA WARRANTY (USA / CANADA)

Contact Admiral Craft for warranty statement at
info@admiralcraft.com or 516.433.3535

GRUCFZ-27

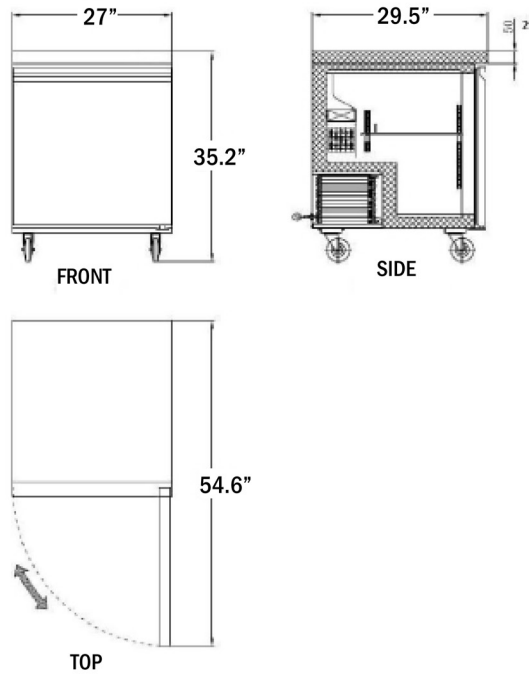

GRUCFZ-48

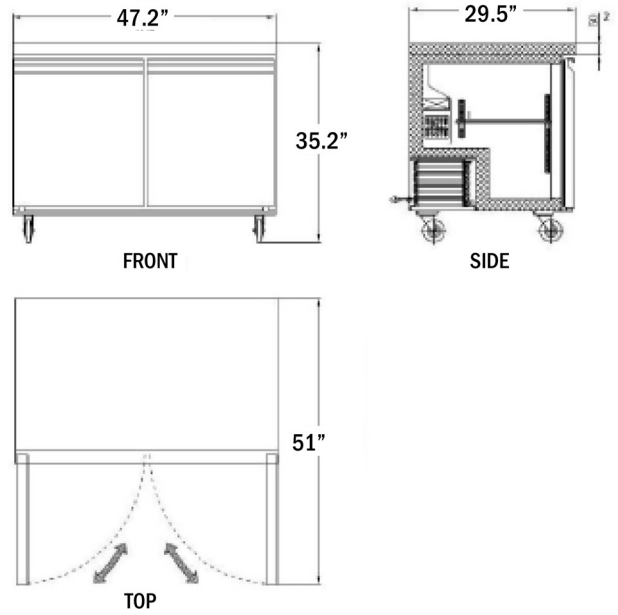

Model Number	GRUCFZ-27	GRUCFZ-48
Doors	1	2
Shelves	1	2
Net Volume (Cu. Ft.)	6.3 Cu. Ft.	12 Cu. Ft.
Overall Dimensions (in)	27\"L × 29.5\"W × 35.2\"H	47.2\"L × 29.5\"W × 35.2\"H
Interior Dimensions (in)	22\"L × 23\"W × 23.5\"H	42.5\"L × 23\"W × 23.5\"H
Horsepower	1/5	1/4+
Refrigerant	R290	R290
Voltage/Hertz/Phase	115/60/1	115/60/1
Amps	2.1	3.12
Net Weight (lbs)	178 lbs	251 lbs
Gross Weight (lbs)	233 lbs	312 lbs
Shipping Dimensions (in)	29.7\"L × 32.5\"W × 38.5\"H	50\"L × 32.5\"W × 38.5\"H