



Please read the following instructions carefully.  
Keep this instruction manual and save for future reference.

Tools required: Phillips head screwdriver, drill  
(for top of stair installation), and pencil (not included),  
wrench (included).

For use with children from 6 - 24 months.

Keep small parts away from children.

Adult assembly required.

Fits openings from 29.5" - 53" wide.

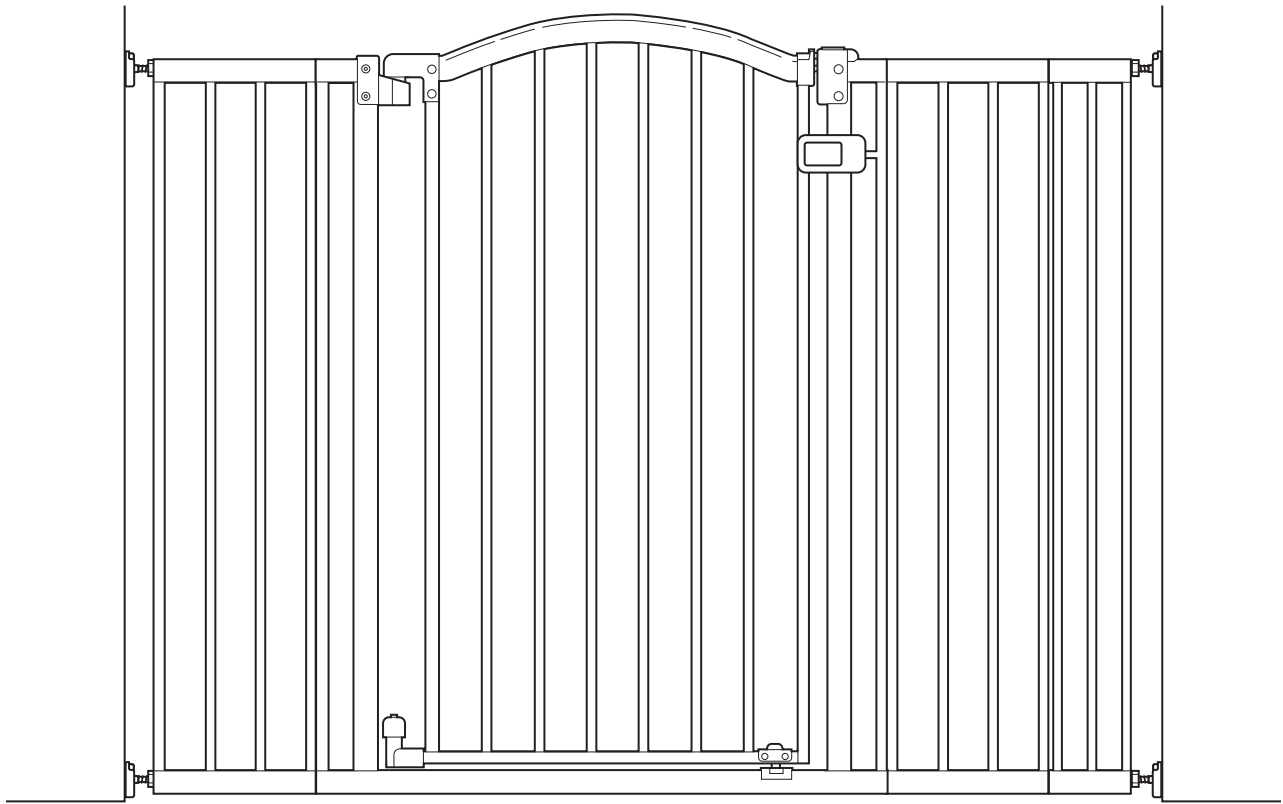

## The Thruway 53W Series™

---

### INSTRUCTION MANUAL

# ⚠ WARNING

**Children have died or been seriously injured when gates are not securely installed.**

- **ALWAYS** install and use gate as directed using all required parts.
- Install according to manufacturer's instructions.
- Stop using when a child can climb over or dislodge the gate.
- Use only with the locking/latching mechanism securely engaged.
- To prevent falls, never use at the top of stairs without hardware mount wall cups and door stopper.
- You **MUST** install wall cups to keep gate in place. Without wall cups, child can push out and escape.
- **NEVER** use a gate to keep child away from pool.
- **NEVER** leave child unattended.
- **ALWAYS** close and lock the gate behind you.
- This product will not necessarily prevent all accidents. Proper adult supervision is required at all times.
- Do not use if any components are missing or damaged.
- Adult assembly required. Exercise care when unpacking and assembling product.

**⚠ CAUTION: KEEP SMALL PARTS OUT OF CHILD'S REACH.**

## components:

**NOTE:** Do NOT cut red zip tie until instructed

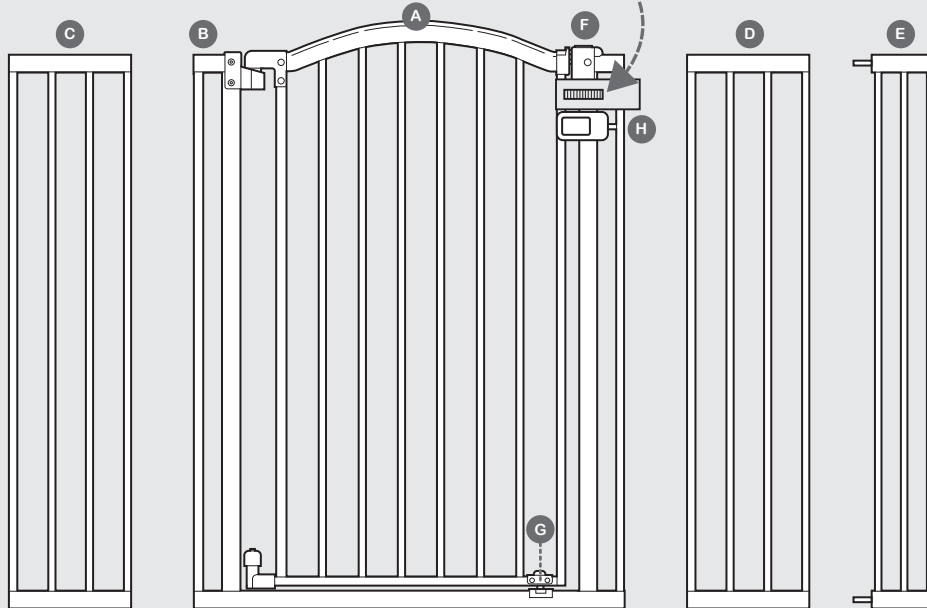

- |                           |                                       |              |
|---------------------------|---------------------------------------|--------------|
| A Gate Door               | G Lower Latch                         | M Screws (4) |
| B Gate Frame              | H Door Stop                           | N Wrench     |
| C Large Extension Frame 1 | I Tension Bolts with Tension Nuts (4) |              |
| D Large Extension Frame 2 | J Adhesive Mounting Pads (4)          |              |
| E Small Extension Frame   | K Wall Cups (4)                       |              |
| F Top Latch               | L Wall Anchors (4)                    |              |

## hardware:

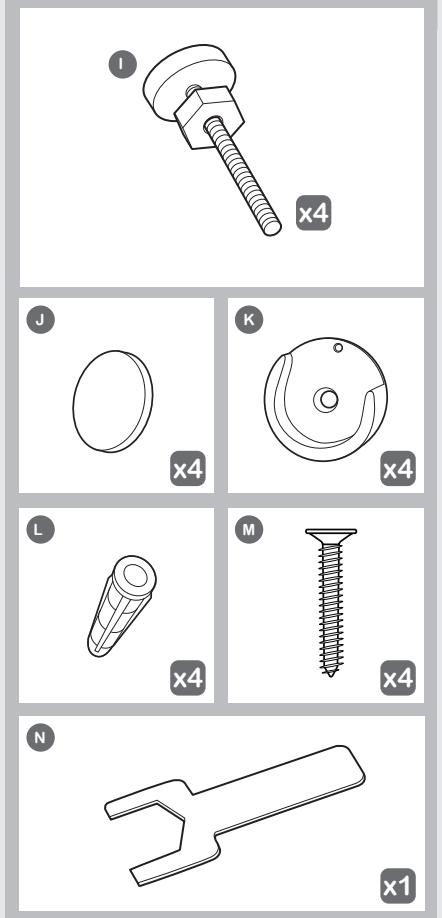

# gate configurations (choose which best fits your scenario):



Measure the width of the opening where you intend to install the gate. Refer to the following illustrations to determine the correct installation configuration. Baseboard molding may change which configuration is appropriate.

## ⚠ WARNING

NEVER install three extension frames on the same side of the gate.

**A**

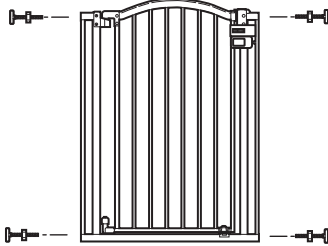

(29.5" - 33") without extension frames

**B**

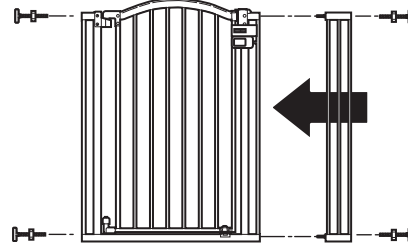

(33.5" - 37") with small extension frame

**C**

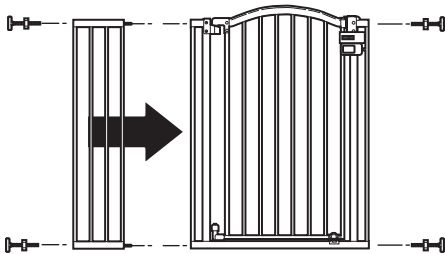

(37.5" - 41") with large extension frame

**D**

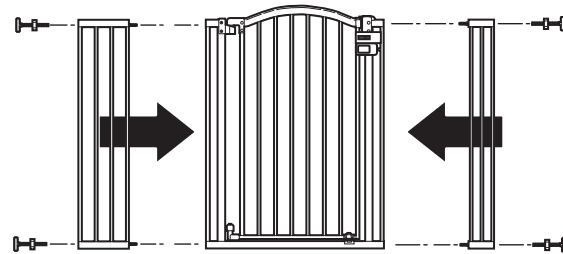

(41.5" - 45") with large and small extension frame

**E**

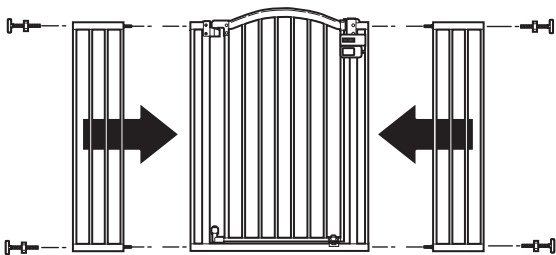

(45.5" - 49") with 2 large extension frames

**F**

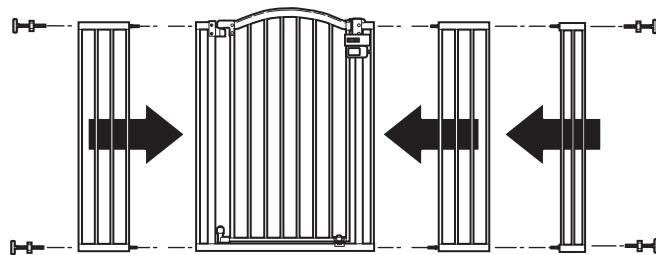

(49.5" - 53") with the 2 large and small extension frames



Note: This instruction book illustrates installation of gate configuration F.

If choosing gate configuration A, skip ahead to step 2. Otherwise, follow step 1 using the appropriate extension frames that best fit your scenario.



**Important:** Gate includes a door stop (part H) which prevents the gate from swinging open in one direction. When installing the gate at the top of stairs, be sure that the door stop is on the stairway side of the gate so the door cannot open over the stairs. While the door stop comes assembled on the gate, it can be removed and installed on either side of the gate frame.

When gate is not used at top of stairs, door stop may be removed to allow gate door to open in either direction.

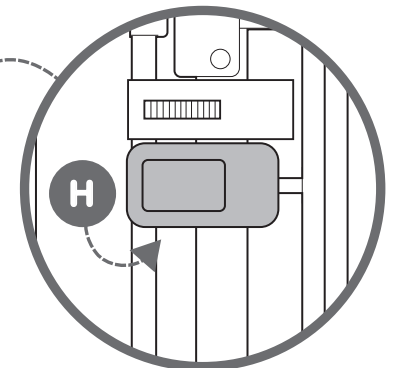

# installation:

1

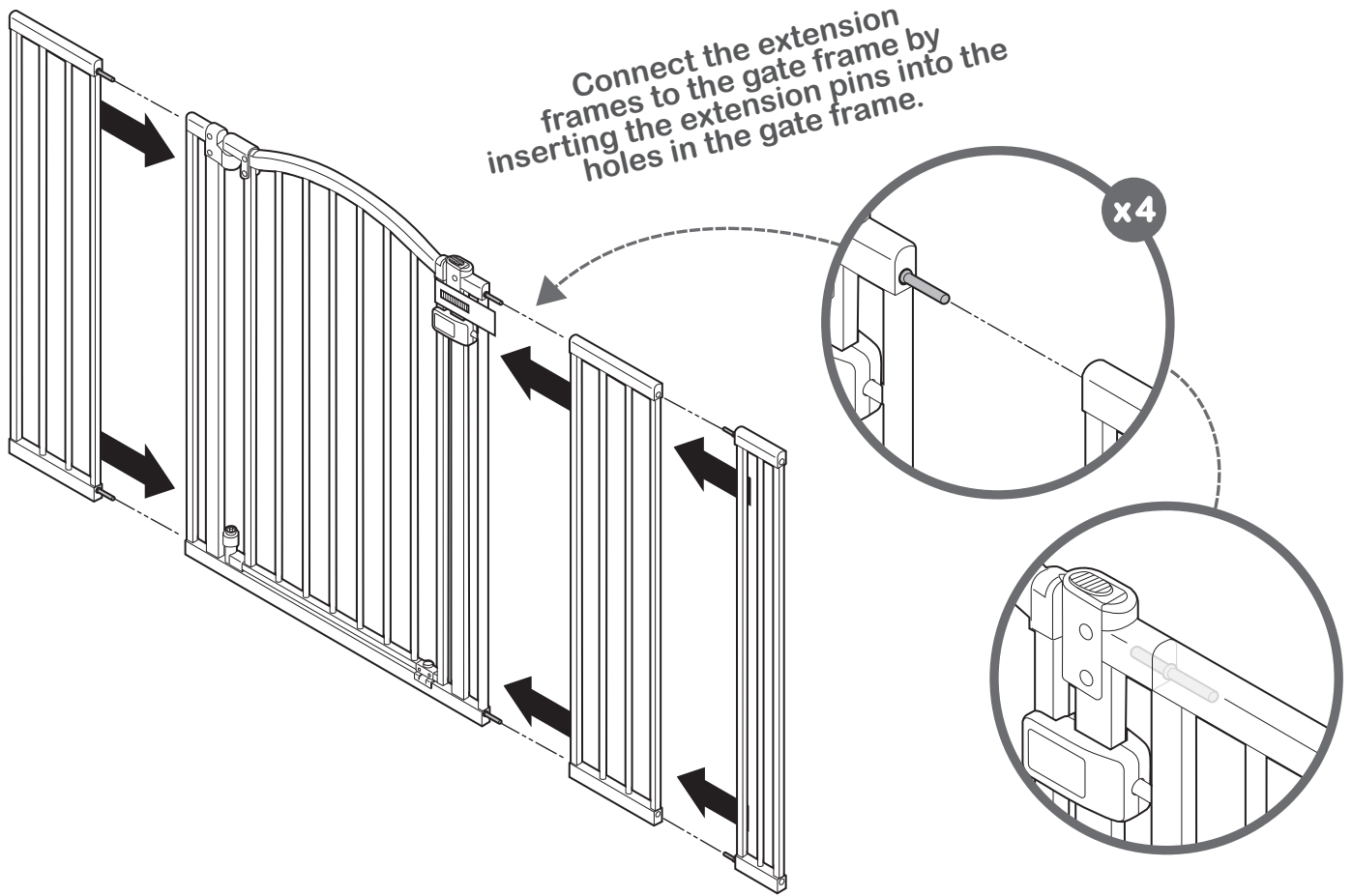

2

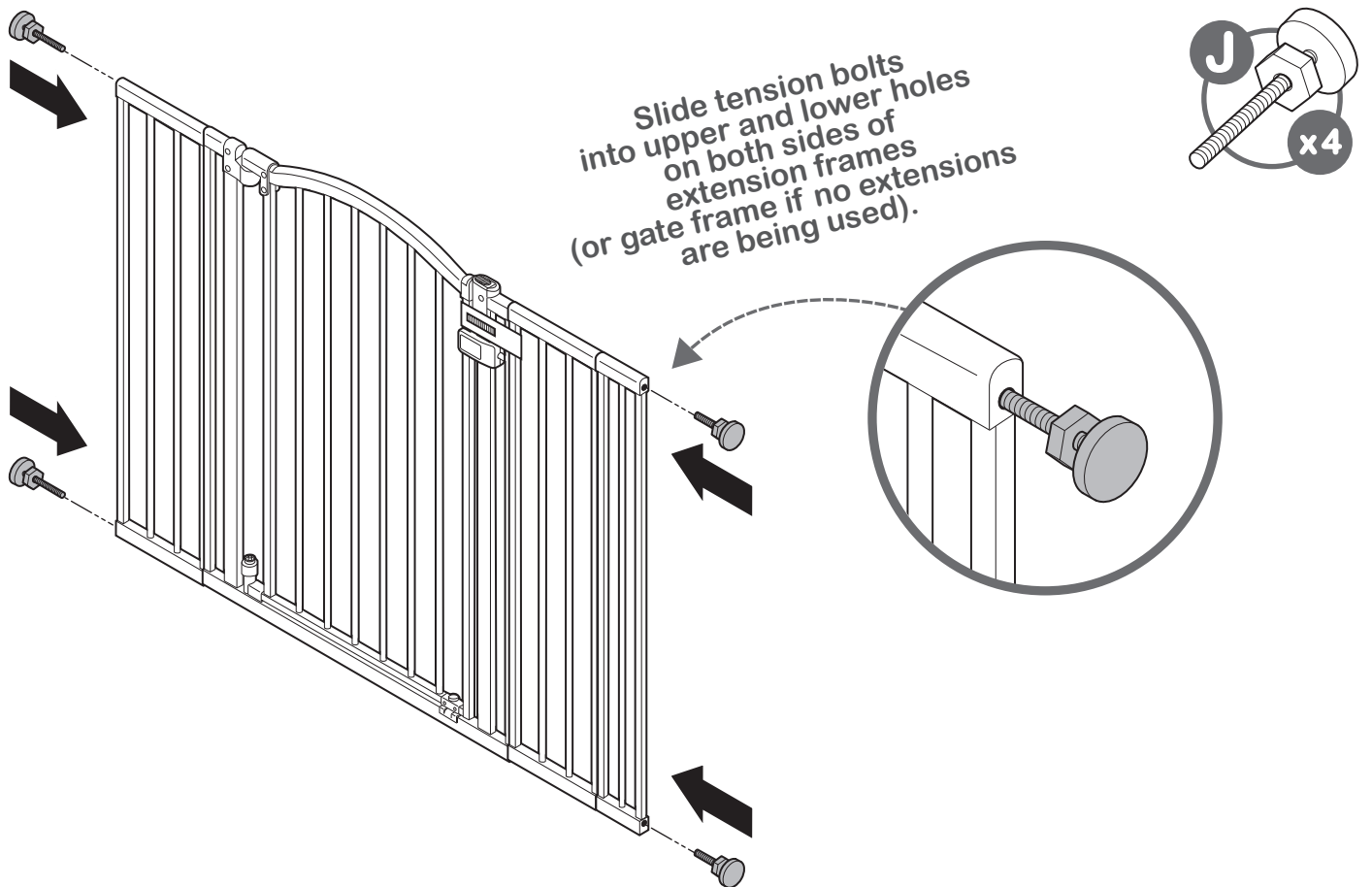

## installation (continued):

3

Stand the gate in the center of the opening. Make sure the bottom of the gate is completely flush to the floor. Slide tension bolts out until they contact the door frame or wall on both sides.

Make sure door stop is facing desired direction. For top of stair use, door stop must be on side of gate that faces away from stairs.

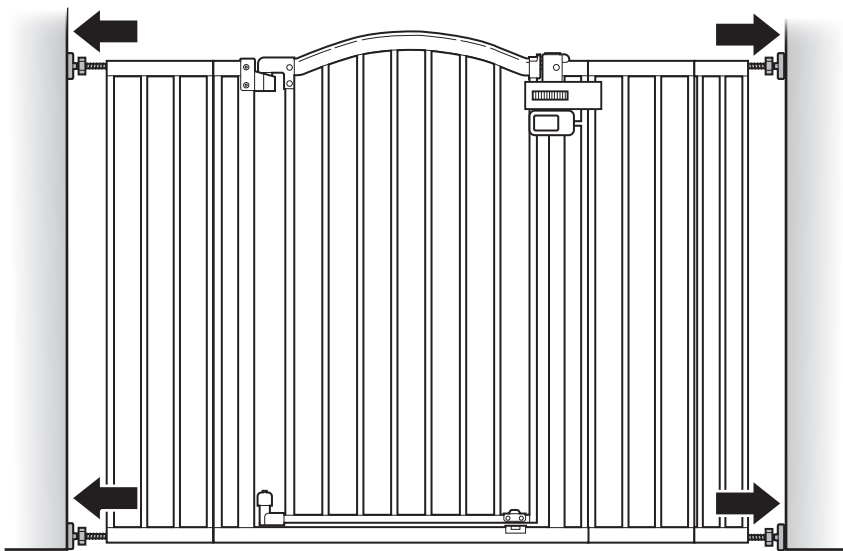

4

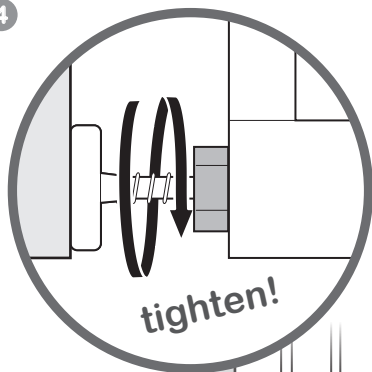

Use the tension nuts to tighten both of the bottom tension bolts.

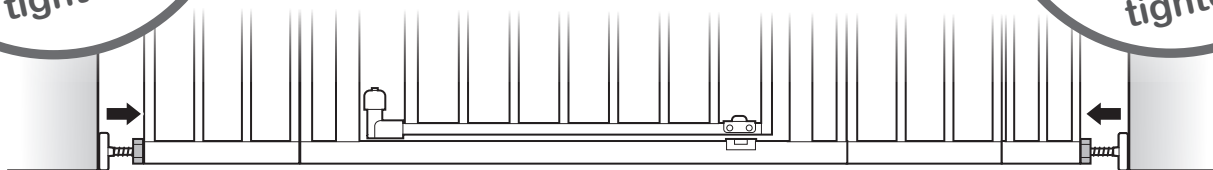
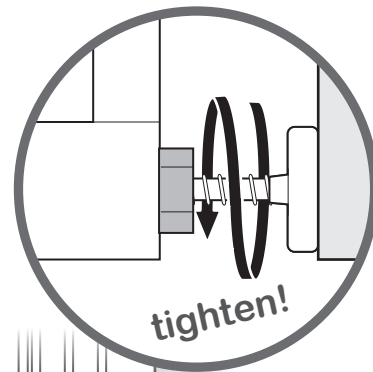

5

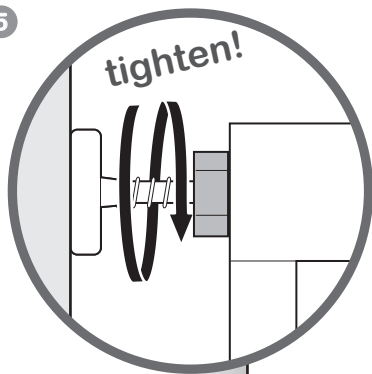

Use the tension nuts to tighten both of the top tension bolts.

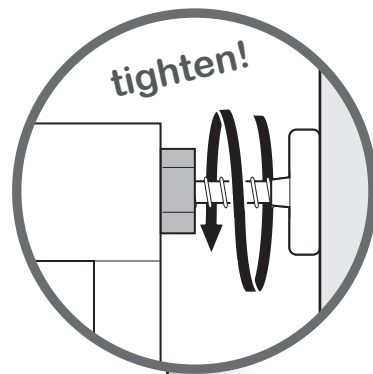

# installation (continued):

6

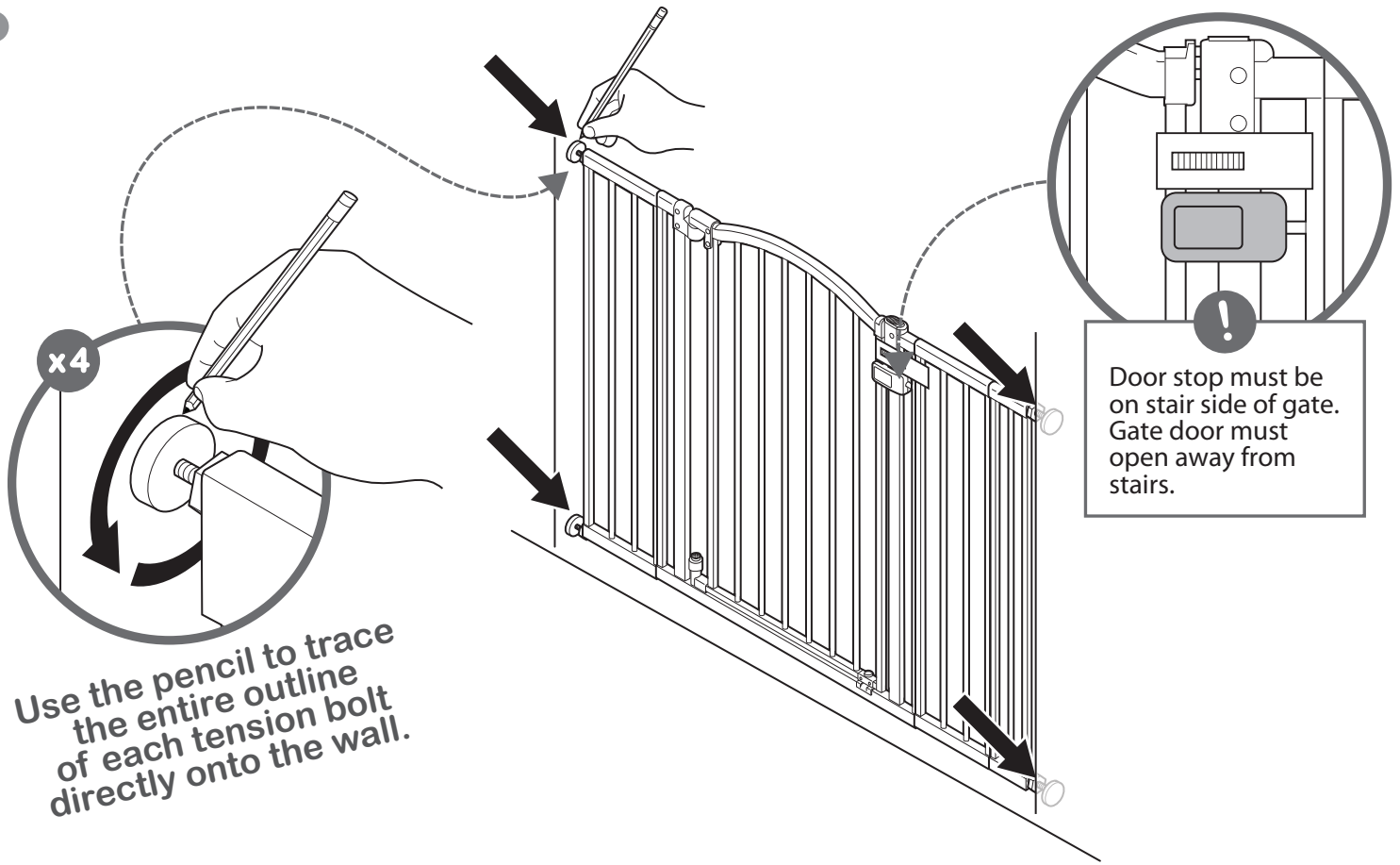

7

Loosen the lower and upper tension nuts and remove gate.

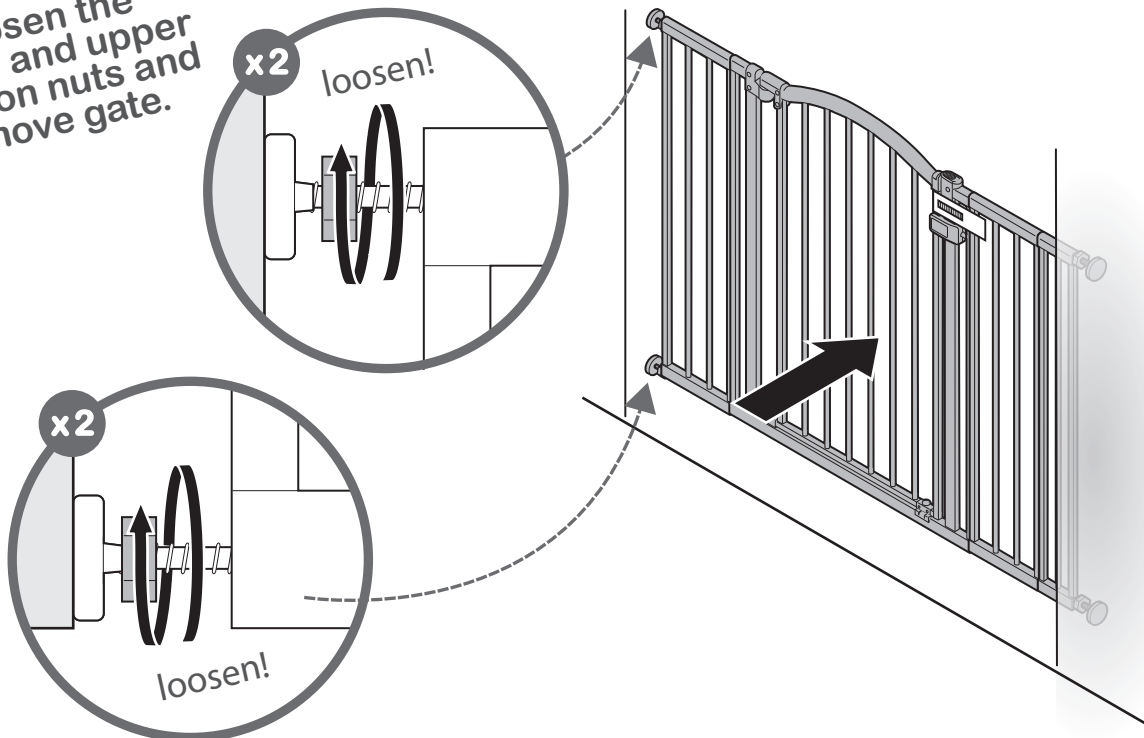

# hardware mount installation:

8 Place a wall cup over the center of each circular outline on the wall.

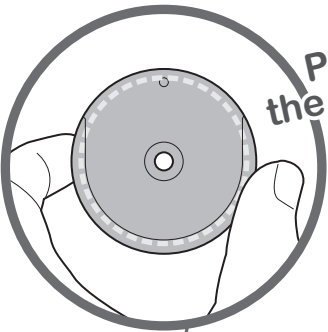

**! WARNING**  
For use at top of stairs, wall cup hardware mount is **MANDATORY**

Mark drill holes with a pencil through the center of each wall cup.

x4

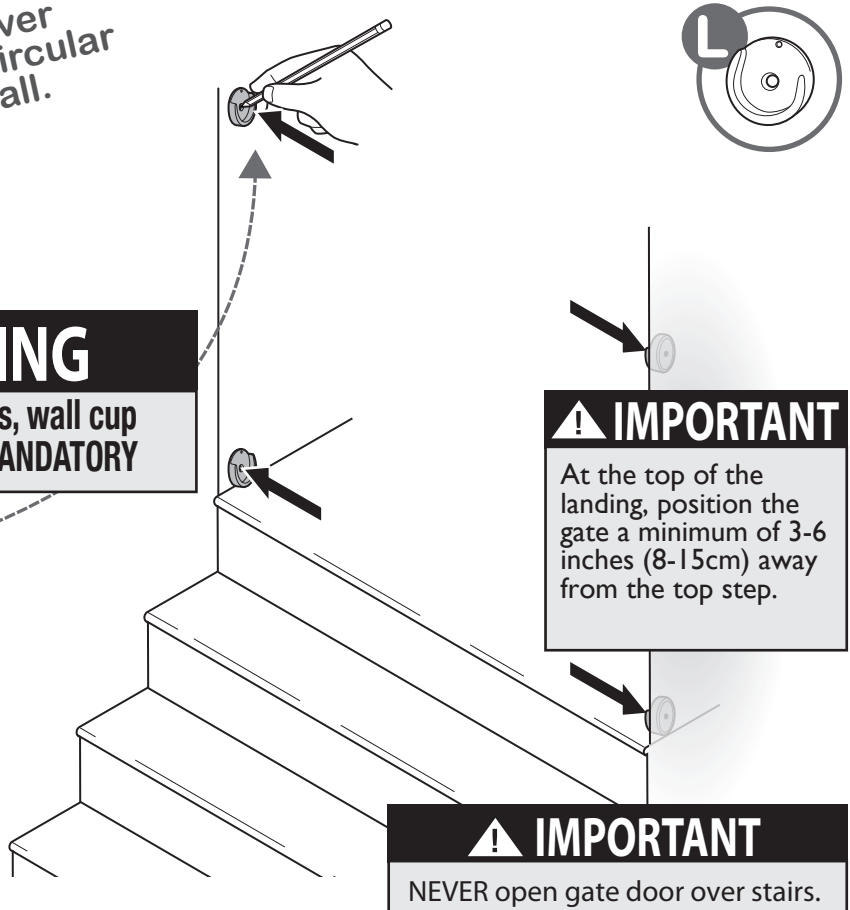

**! IMPORTANT**  
At the top of the landing, position the gate a minimum of 3-6 inches (8-15cm) away from the top step.

**! IMPORTANT**  
NEVER open gate door over stairs.



9

**1st**  
Drill a 7/32" pilot hole into each of the 4 center marks.

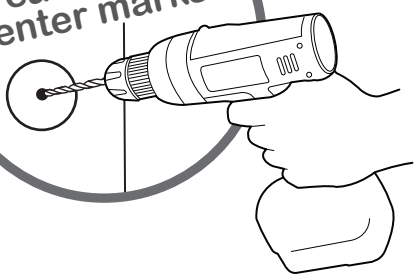

**2nd**  
Insert wall anchors into pilot holes.

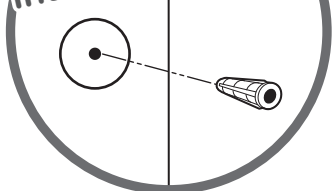

**!**  
**Note:** If mounting into plaster or drywall, follow this step and use the wall anchors provided.

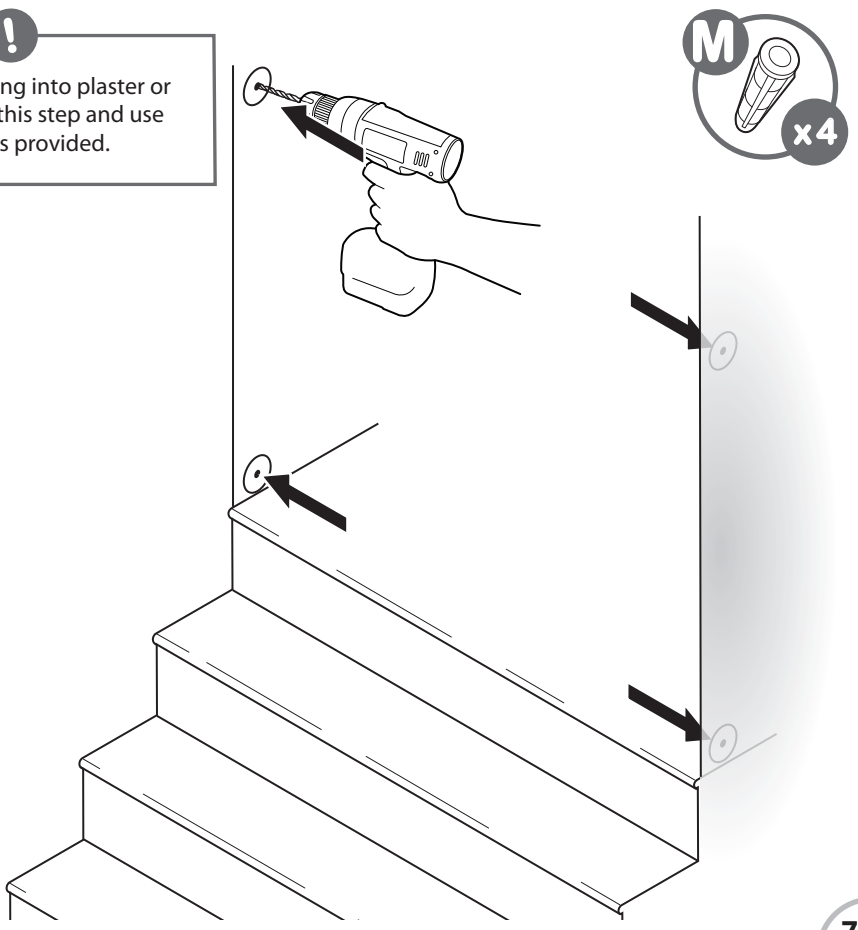

x4

# hardware mount installation:



Screw  
wall cups  
into wall.

10

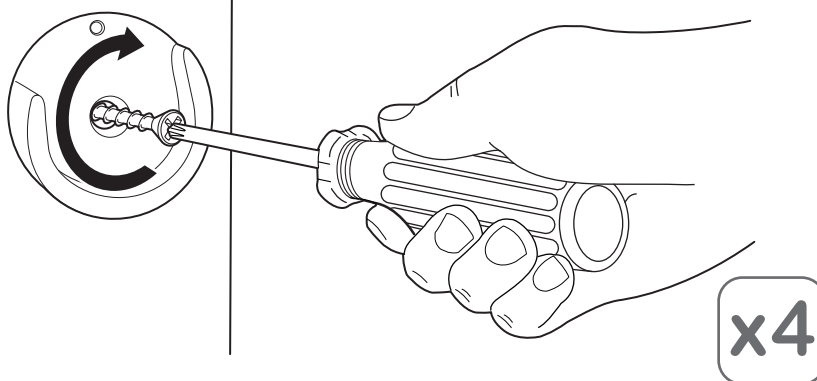
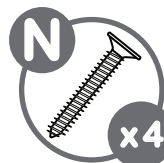

11

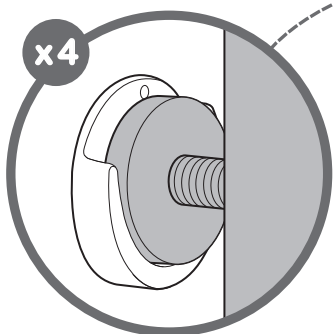

Repeat "installation"  
steps on page 5.  
The 4 tension bolts  
will rest within  
each wall cup.

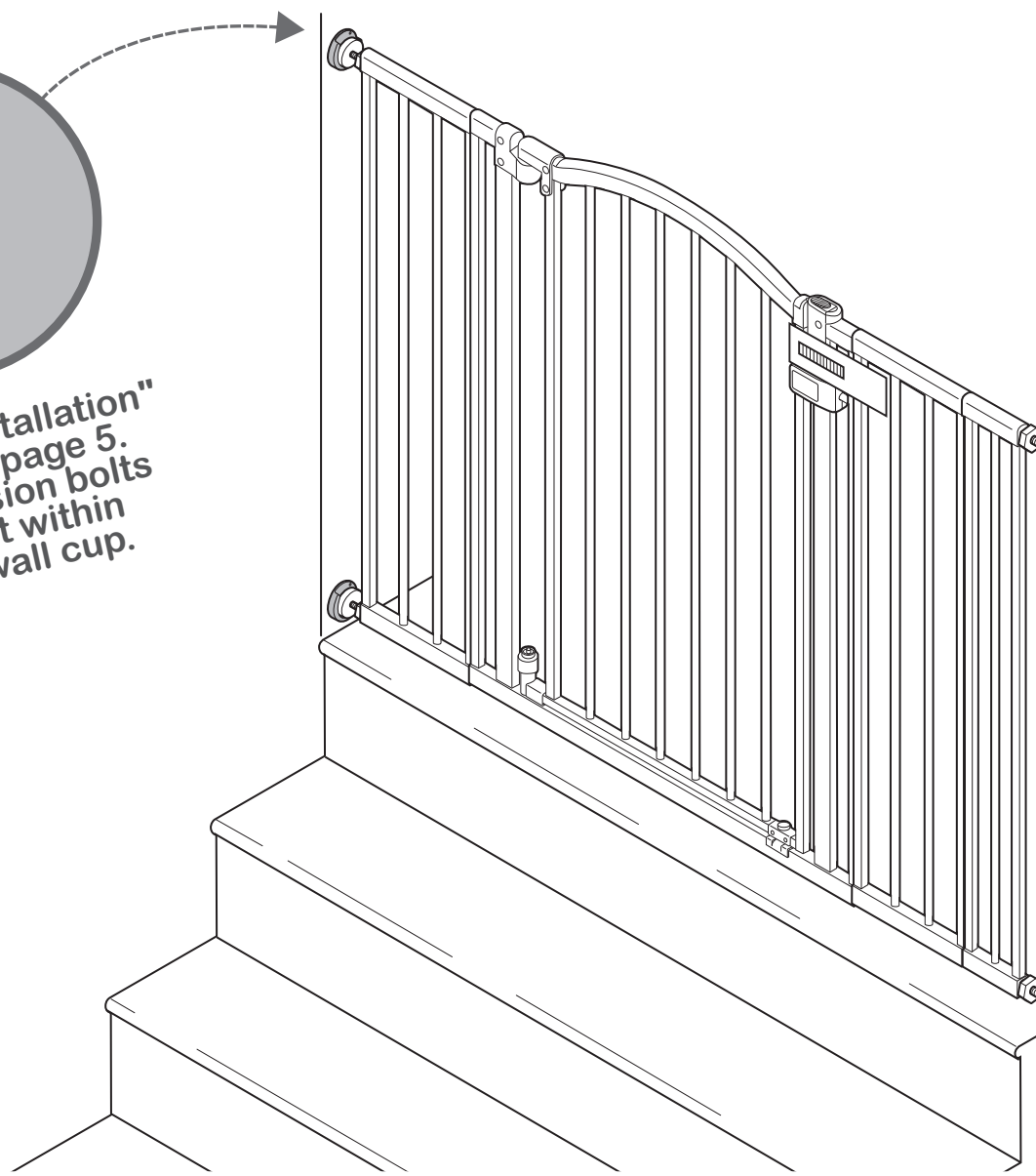



## hardware mount installation:

12

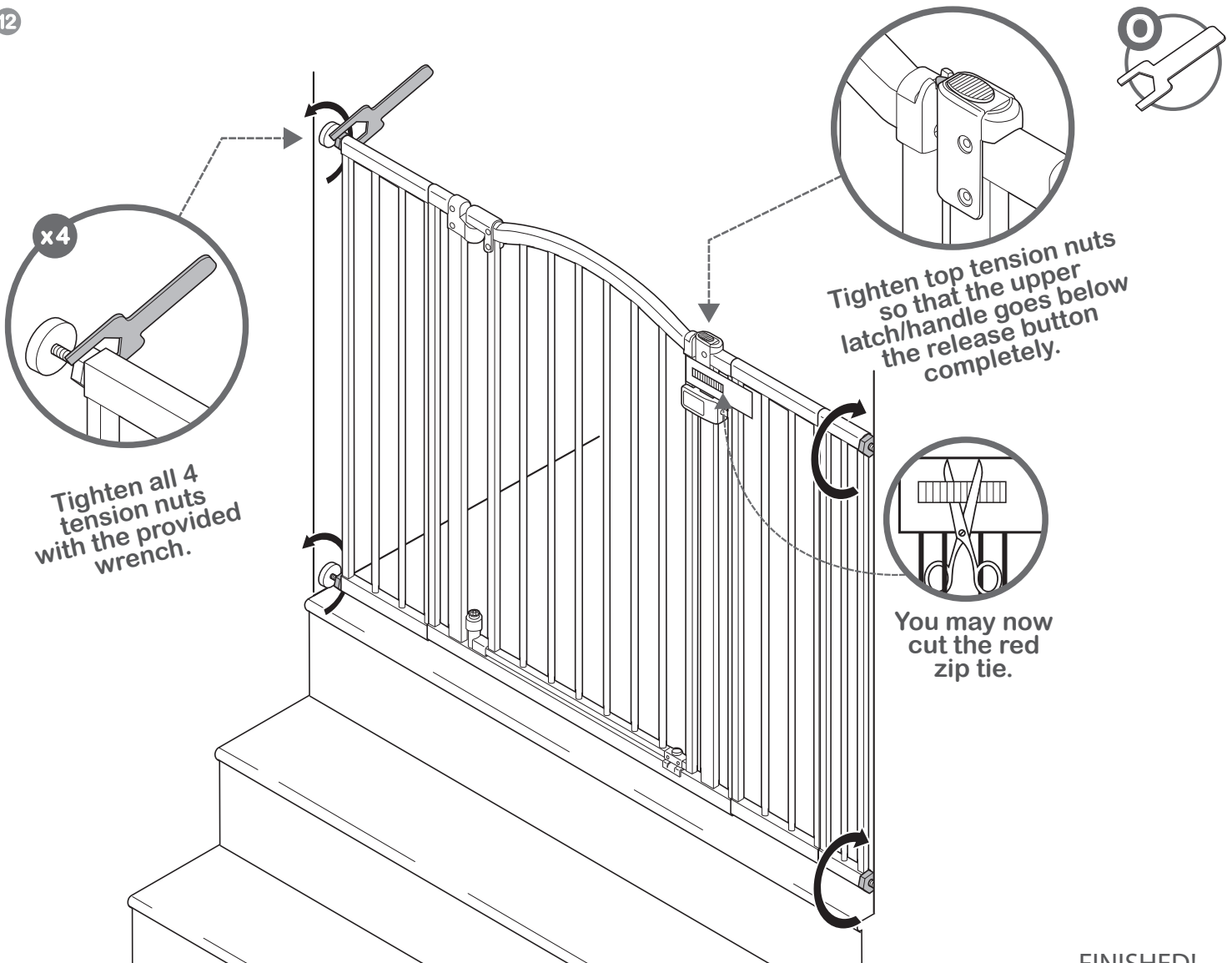

FINISHED!

## pressure mount installation:

1

**1<sup>st</sup>**  
Remove backing from one side of each adhesive mounting pad.

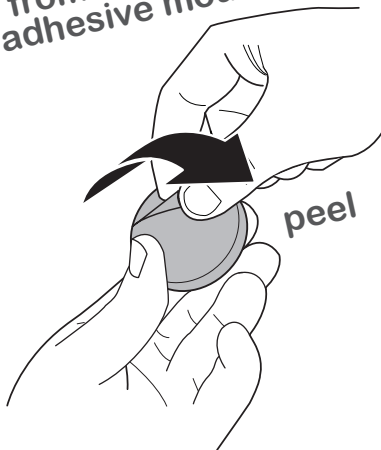

**2<sup>nd</sup>**  
Attach one pad to the back of each wall cup.

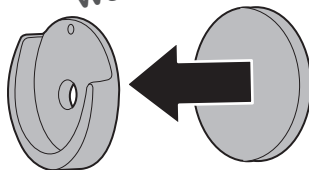

**3<sup>rd</sup>**  
Remove backing.

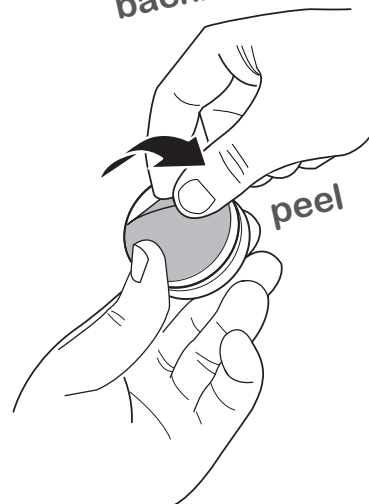

2

Place your wall cups facing up in the outline created in step 6. Stick the wall cups to the wall and hold for several seconds.

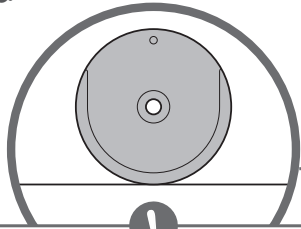

**Note:** The bottom wall cups should rest on the floor.

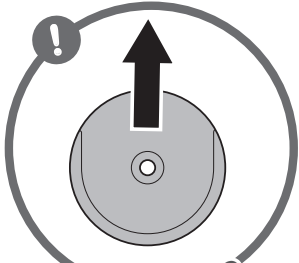

Make sure all wall cups are facing up.



3

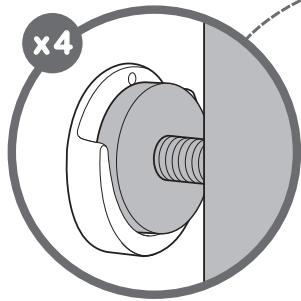

Repeat "installation" steps on page 5. The 4 tension bolts will rest within each wall cup.

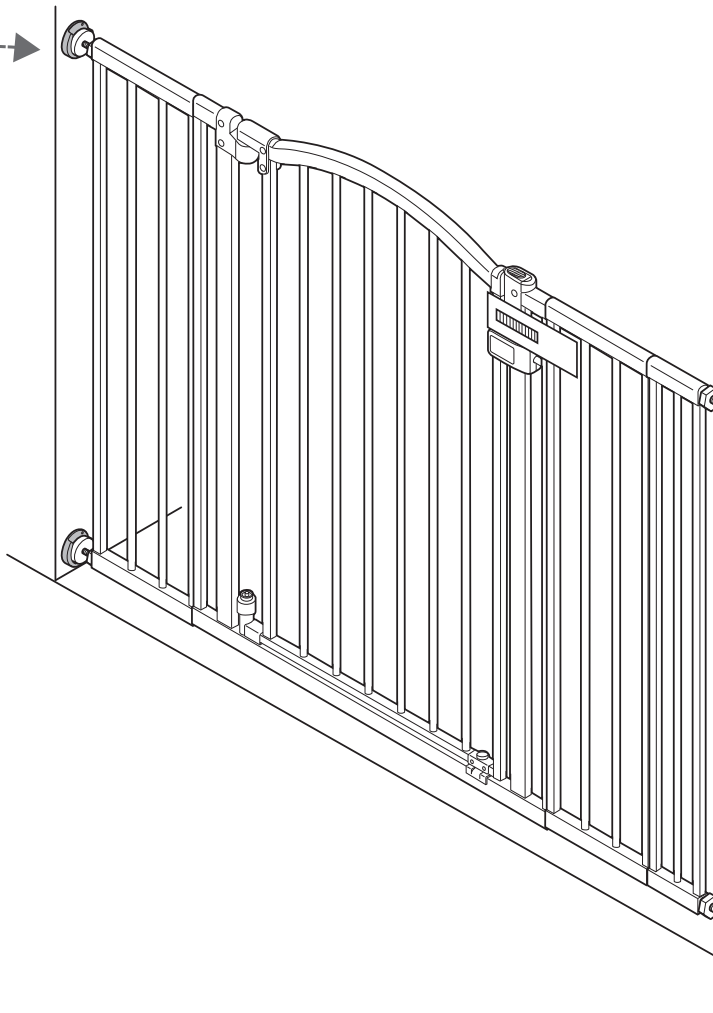

4

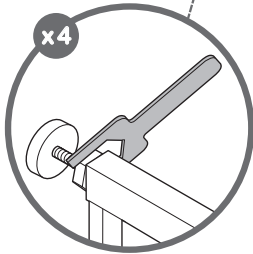

Tighten all 4 tension nuts with the provided wrench.

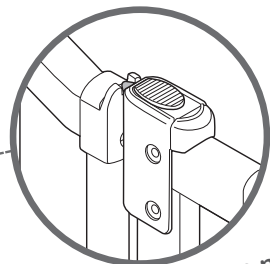

Tighten top tension nuts so that the upper latch/handle goes below the release button completely.

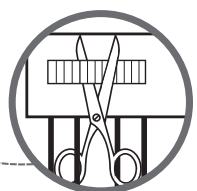

You may now cut the red zip tie.

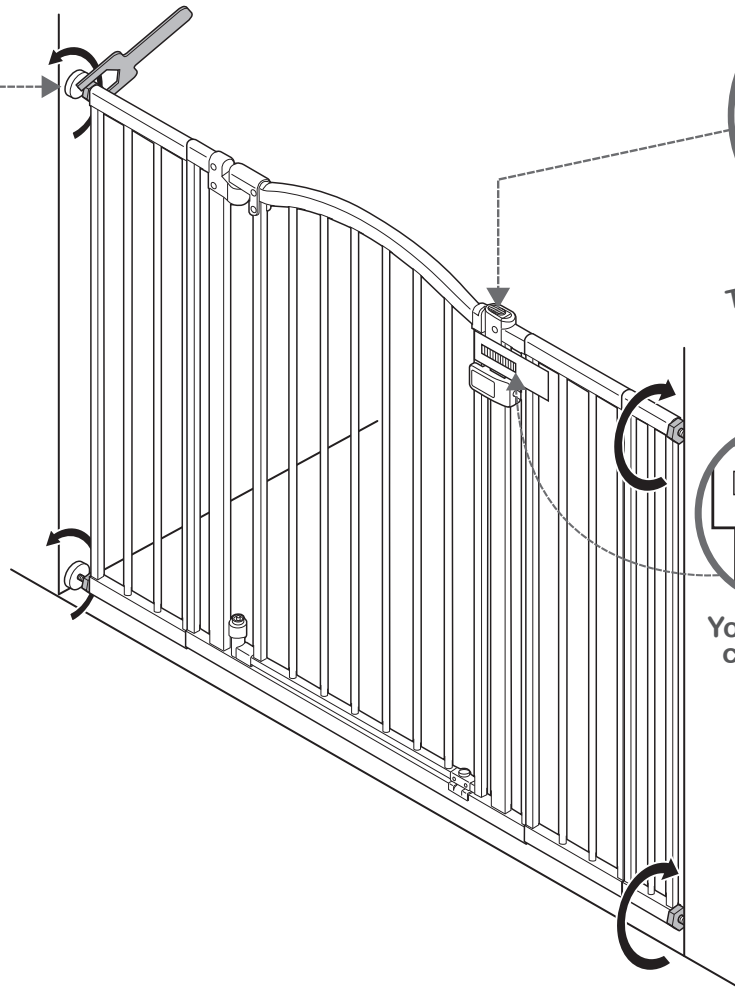

**FINISHED!**

**testing the installation:**

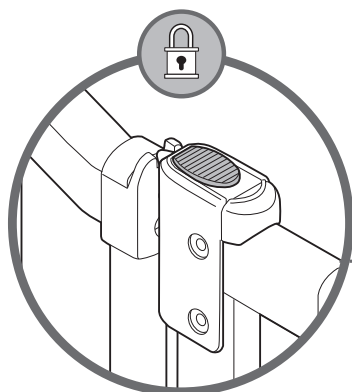

**1<sup>st</sup>**

Close the gate. Make sure the upper and lower latches lock securely.

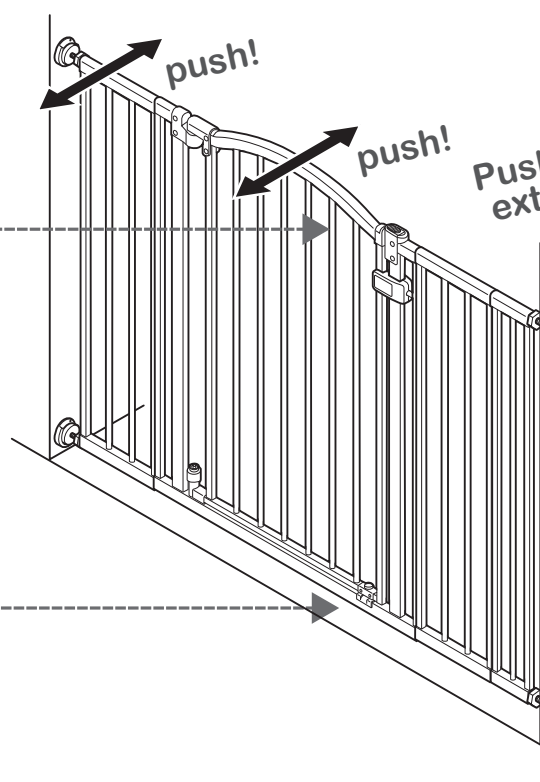
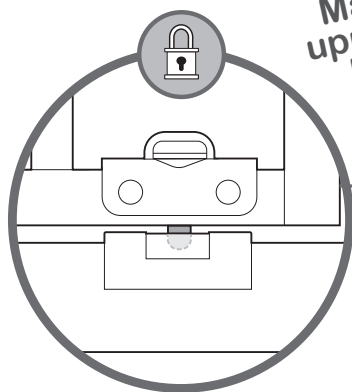

**2<sup>nd</sup>**

Push the gate and extension frames to check stability.

## operation:



to unlock gate:

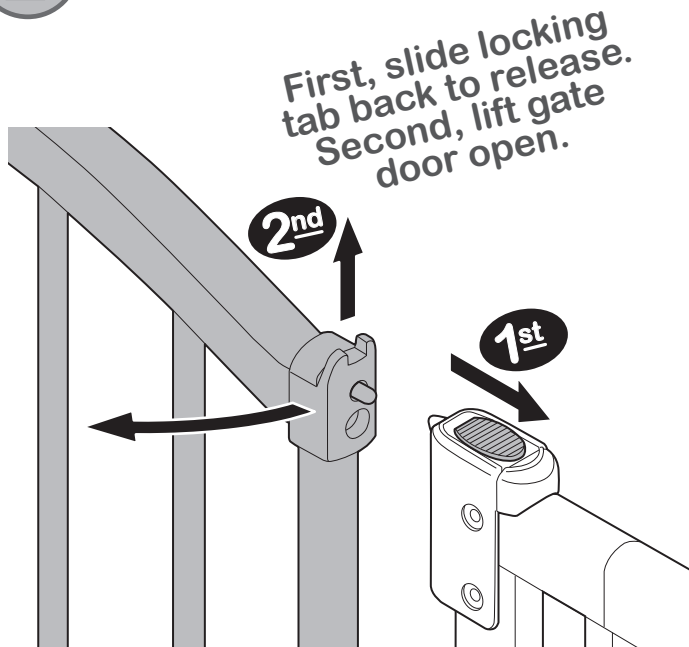

hold open feature:

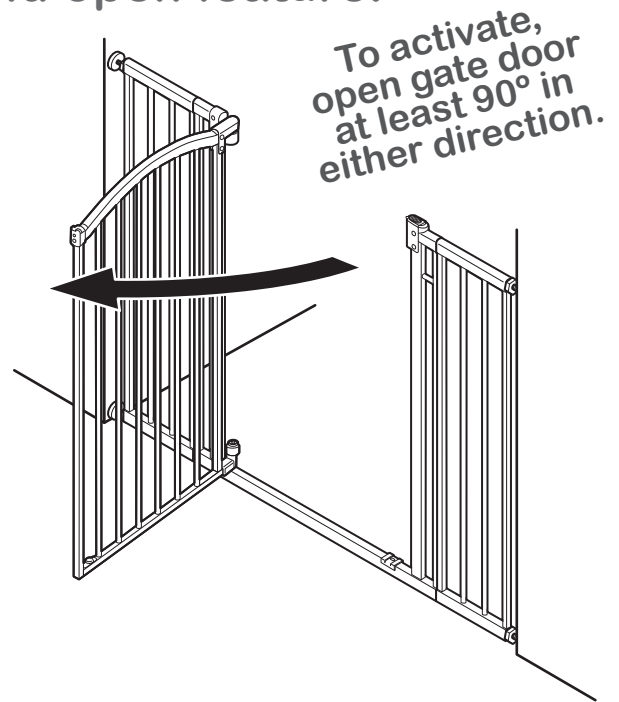

## troubleshooting:

If the gate does not close properly:

**1. Gate is not properly aligned in the door frame.**

**Solution:** To adjust the gate's alignment, loosen all four tension bolts and reposition gate so that it matches the "correct" image. Re-tighten tension bolts.

**2. Pressure of tension bolts needs to be adjusted.**

**Solution:** Loosen or tighten the upper tension bolts. Ensure the upper latch engages securely when the gate swings closed, and that it can be released properly when the sliding lock tab is pushed back.

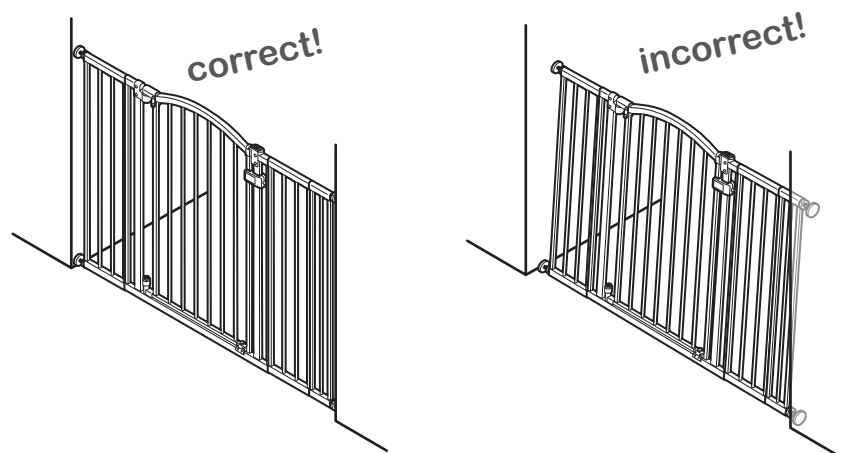

## maintenance:

- Regularly check tension bolts to make sure the gate is securely in place.
- Do not use the gate if any components are damaged or missing.
- Surface clean with a damp cloth or sponge using mild detergent and warm water.

MANUFACTURED FOR • FABRIQUÉ POUR **kids2™ okids II®** ©2024 KIDS2, LLC [www.kids2.com/help](http://www.kids2.com/help)

KIDS2, LLC ATLANTA, GA USA 30305 • 1-800-230-8190

IMPORTED BY • IMPORTÉ PAR

KIDS2 CANADA CO. PO BOX 54059, RPA LAWRENCE PLAZA, TORONTO, ON. M6A 3B7

KIDS2 AUSTRALIA PTY LIMITED CASTLE HILL, NSW AUSTRALIA 2154 • (02) 9894-1855

KIDS2 JAPAN K.K. c/o ARK Outsourcing KK 4-3-5-704, Ebisu, Shibuya-ku, Tokyo, Japan 150-0013 • (03) 5322-6081

KIDS2 UK LTD. GROUND FLOOR, SUITE A1A, BREAKSPEAR PARK, BREAKSPEAR WAY, HEMEL HEMPSTEAD,

HP2 4TZ • +44 01582 816 080

KIDS2 EUROPE BV 5 KEIZERS, KEIZERSGRACHT 287, 1016 ED AMSTERDAM, NETHERLANDS • +31 20 2410934

KIDS2 US MÉXICO S.A. DE C.V. • (55) 5292-8488

MADE IN CHINA • HECHO EN CHINA • FABRIQUÉ EN CHINE

Colors and styles may vary.

**MADE IN CHINA.**

17172, 17173\_092624

# ingenuity™

Lire attentivement les instructions et les avertissements suivants.

Conserver ce mode d'emploi pour toute consultation ultérieure.

Outils nécessaires : Tournevis cruciforme, perceuse  
(pour l'installation en haut des escaliers)  
et crayon (non fourni), clé (fournie).

Pour une utilisation avec des enfants de 6 à 24 mois.

Garder les petites pièces à l'écart des enfants.

Doit être assemblée par un adulte.

Convient aux ouvertures d'une largeur de 75 à 134,6 cm (29,5 à 53 po).

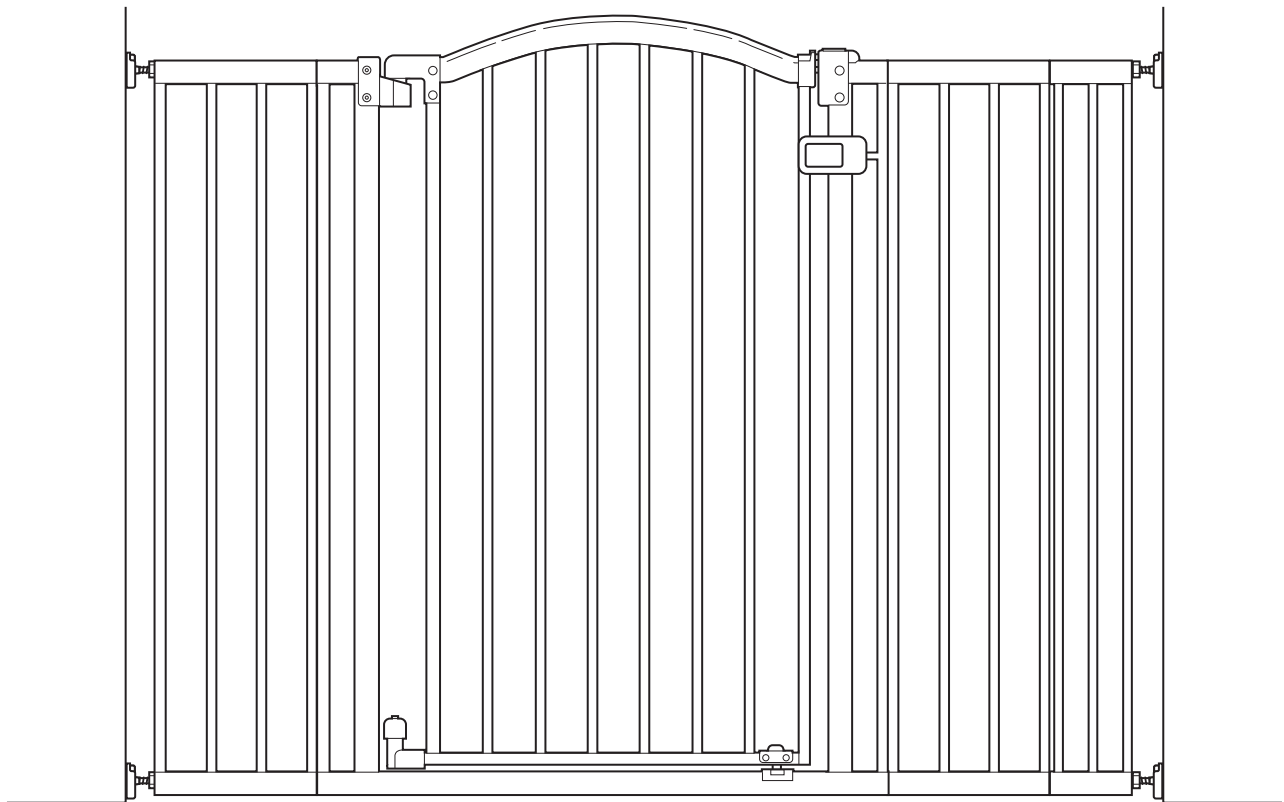

**The Thruway 53W Series<sup>MC</sup>**

---

**MODE D'EMPLOI**

# ⚠ MISE EN GARDE

**Des enfants sont morts ou ont été grièvement blessés lorsque les barrières n'étaient pas installées de façon sécuritaire.**

- **TOUJOURS** installer et utiliser la barrière selon les instructions en utilisant toutes les pièces nécessaires.
- Installer selon les instructions du fabricant.
- Arrêter de l'utiliser lorsqu'un enfant peut grimper par-dessus ou déplacer la barrière.
- Utiliser uniquement lorsque le mécanisme de verrouillage est bien bloqué.
- Afin d'éviter les chutes, ne jamais utiliser en haut d'un escalier sans installation préalable de coupelles murales et de verrou barrière.
- Les tampons de protection murale **DOIVENT** être installés pour maintenir la barrière en place. Sans les tampons de protection murale, l'enfant peut pousser la barrière et s'échapper.
- **NE JAMAIS** utiliser une barrière pour tenir l'enfant éloigné de la piscine.
- **NE JAMAIS** laisser l'enfant sans surveillance.
- **TOUJOURS** fermer et verrouiller la barrière derrière vous.
- Ce produit ne préviendra pas nécessairement tous les accidents. La supervision par un adulte est impérative en tout temps.
- Ne pas utiliser si des éléments sont manquants ou endommagés.
- Doit être assemblée par un adulte. Prendre les précautions nécessaires lors du déballage et de l'assemblage du produit.

**⚠ ATTENTION : GARDER LES PETITES PIÈCES HORS DE LA PORTÉE DES ENFANTS.**

## composants :

**REMARQUE :** Ne PAS couper l'attache autobloquante rouge jusqu'à en recevoir l'instruction

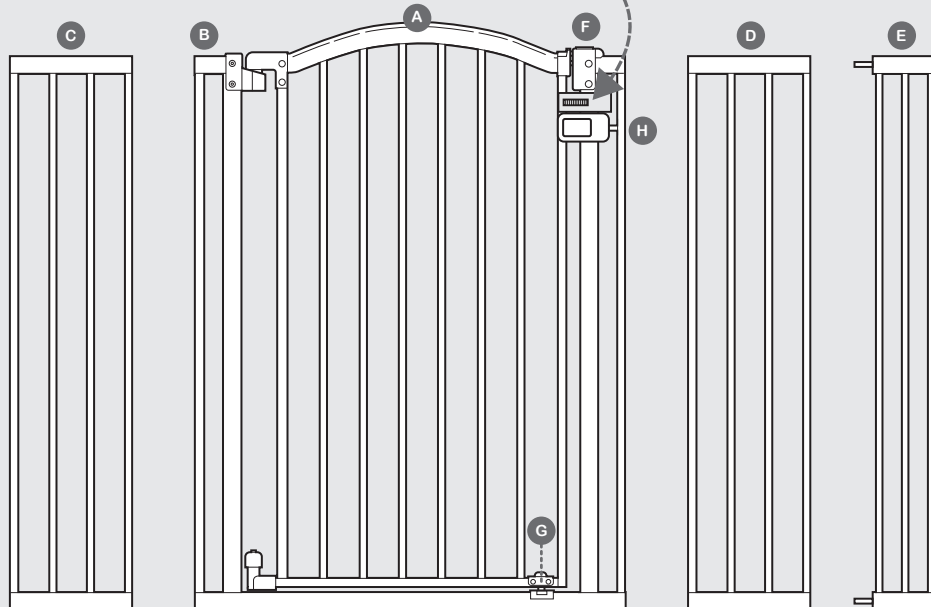

- |   |                           |   |   |   |                |
|---|---------------------------|---|---|---|----------------|
| A | Porte de la barrière      | G | Loquet inférieur                              | M | Vis (4)        |
| B | Cadre de la barrière      | H | Butée de porte                                | N | Clé hexagonale |
| C | Grand cadre d'extension 1 | I | Boulons de tension avec écrous de tension (4) |   |                |
| D | Grand cadre d'extension 2 | J | Coussinets de montage adhésifs (4)            |   |                |
| E | Petit cadre d'extension   | K | Tampons de protection murale (4)              |   |                |
| F | Loquet supérieur          | L | Ancrages muraux (4)                           |   |                |

## fixations :

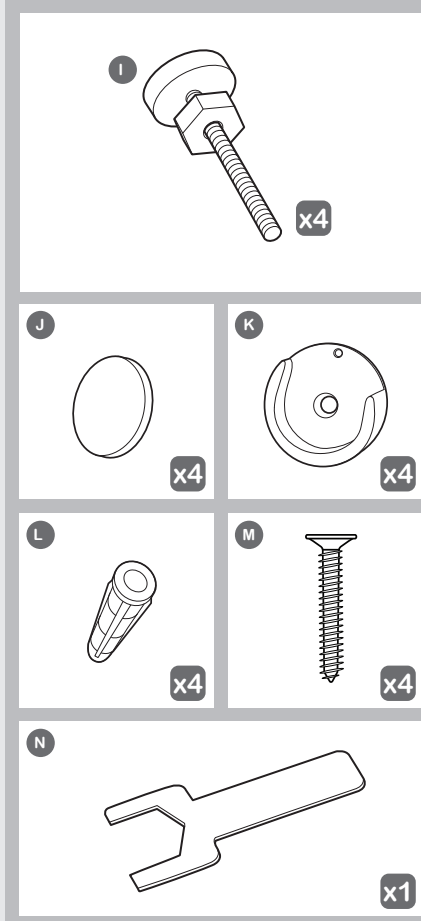

# configurations de la barrière (choisir l'option la plus adaptée selon le cas) :



Mesurer la largeur de l'ouverture dans laquelle la barrière va être installée. Se reporter aux illustrations qui suivent pour déterminer la configuration d'installation adaptée. Les plinthes peuvent modifier la configuration appropriée.

## ⚠ MISE EN GARDE

NE JAMAIS installer trois cadres d'extension du même côté de la barrière.

**A**

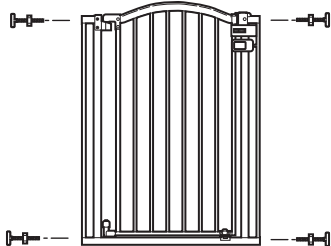

(75 à 84 cm [29,5 à 33 po]) sans cadre d'extension

**B**

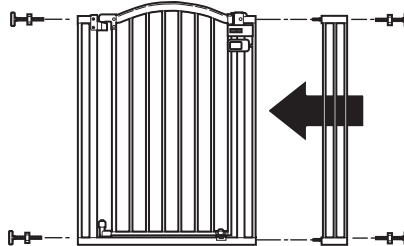

(85 à 94 cm [33,5 à 37 po]) avec un petit cadre d'extension

**C**

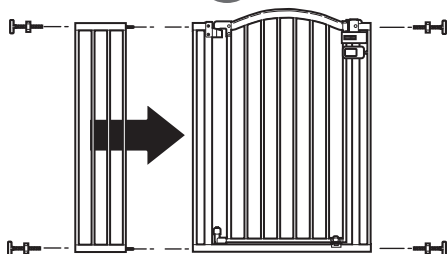

(95,3 à 104 cm [37,5 à 41 po]) avec un grand cadre d'extension

**D**

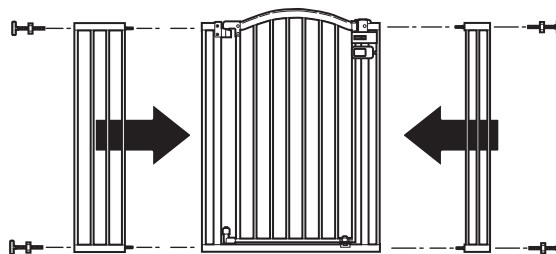

(105,4 à 114,3 cm [41,5 à 45 po]) avec un petit cadre et un grand cadre d'extension

**E**

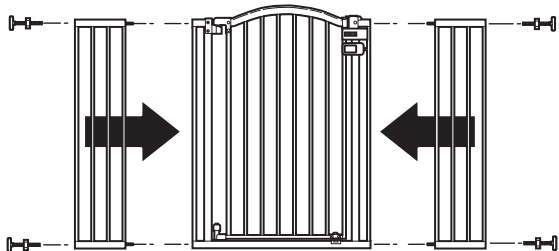

(115,6 à 124,5 cm [45,5 à 49 po]) avec 2 grands cadres d'extension

**F**

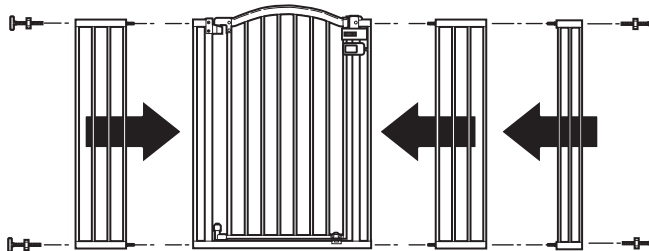

(125,7 à 134,6 cm [49,5 à 53 po]) avec 2 grands cadres et un petit cadre d'extension



Remarque : Ce manuel d'instructions illustre l'installation de la configuration de la barrière F.

En cas de choix de configuration de la barrière A, passer à l'étape 2. Sinon, suivre l'étape 1, en utilisant les cadres d'extension appropriés qui correspondent le mieux au scénario souhaité.



**IMPORTANT :** La barrière comprend une butée de porte (composant H) qui empêche la barrière de s'ouvrir dans un sens. Lors de l'installation de la barrière en haut des escaliers, s'assurer que la butée de la porte se trouve du côté de l'escalier afin que la porte ne puisse pas s'ouvrir par-dessus les escaliers. La butée de porte est livrée montée sur la barrière, mais elle peut être retirée et installée de chaque côté du cadre de la barrière.

Lorsque la barrière n'est pas utilisée en haut des escaliers, la butée de porte peut être retirée pour permettre à la barrière de s'ouvrir dans l'une ou l'autre direction.

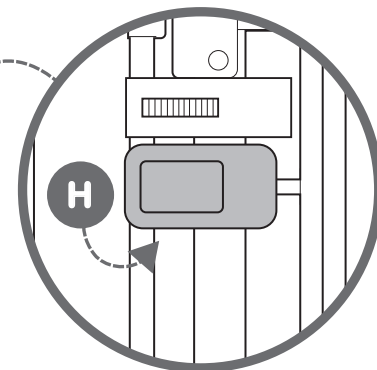

# installation :

1

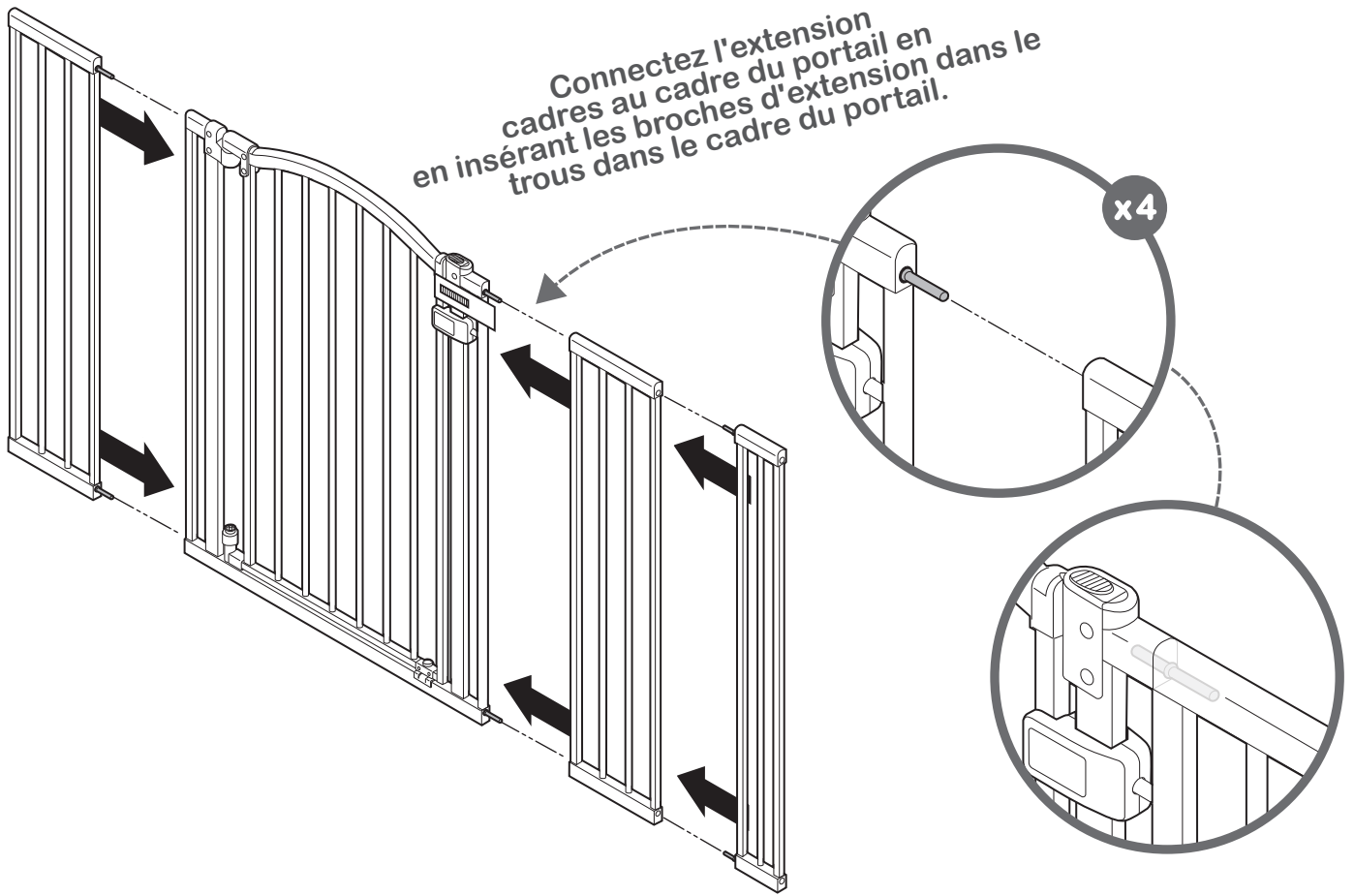

2

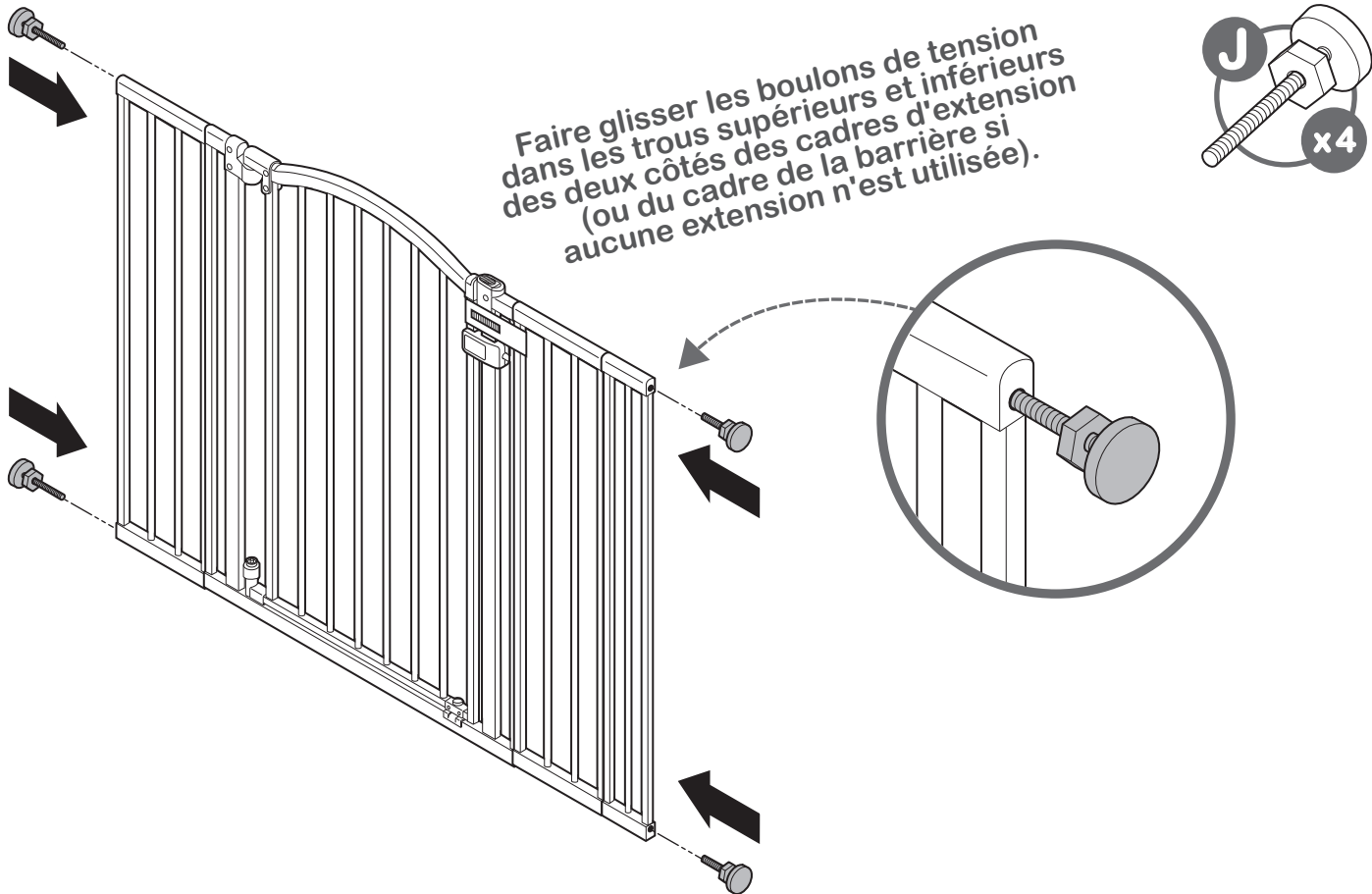



## installation (suite) :

3

Placer la barrière au centre de l'ouverture. Vérifier que le bas de la barrière est complètement de niveau avec le sol. Faire glisser les boulons de tension vers l'extérieur jusqu'à ce qu'ils touchent l'armature de la porte ou le mur des deux côtés.

Assurez-vous que la butée de porte est du bon côté. Pour l'utilisation en haut des escaliers, la butée de porte doit se trouver du côté de la barrière qui est à l'opposé des escaliers.

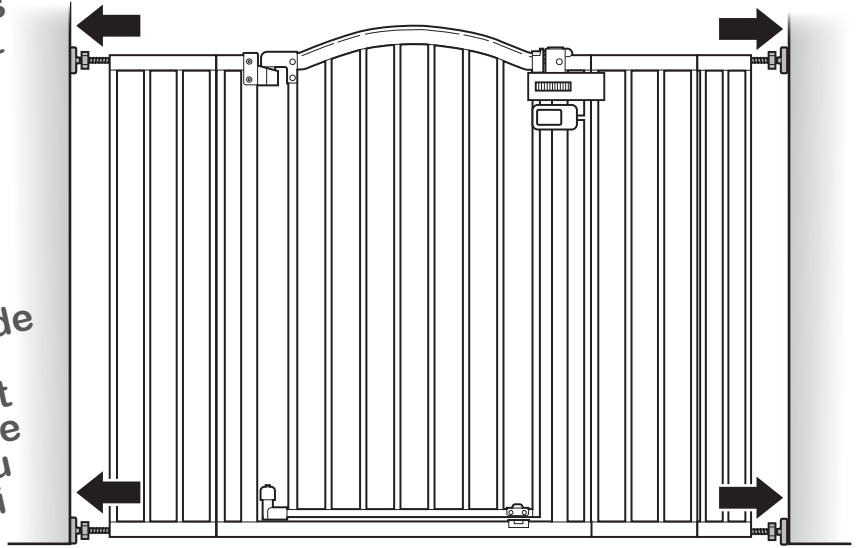

4

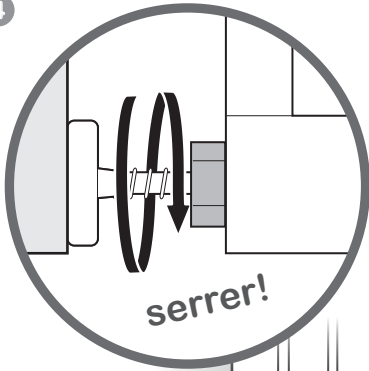

Utiliser les écrous de tension pour serrer les deux boulons de tension inférieurs.

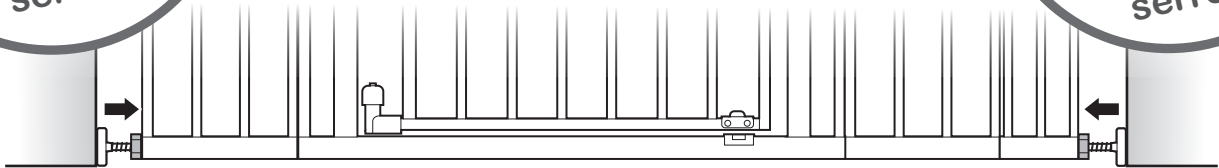
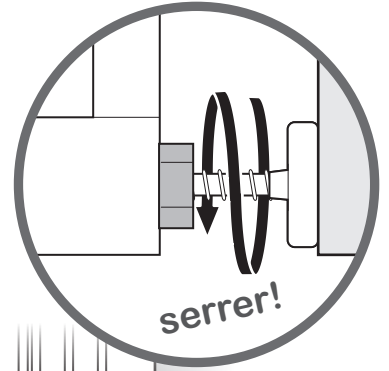

5

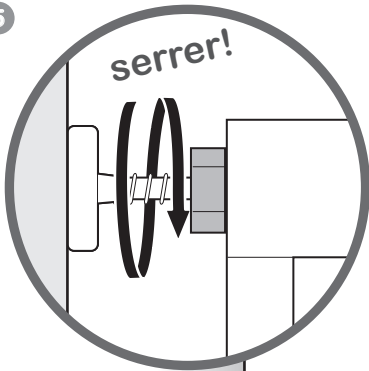

Utiliser les écrous de tension pour serrer les deux boulons de tension supérieurs.

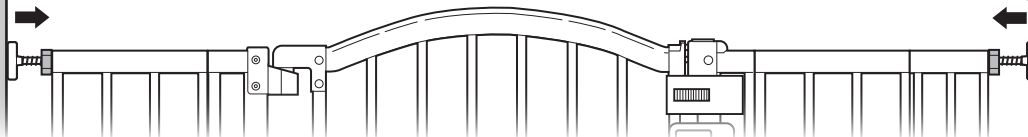
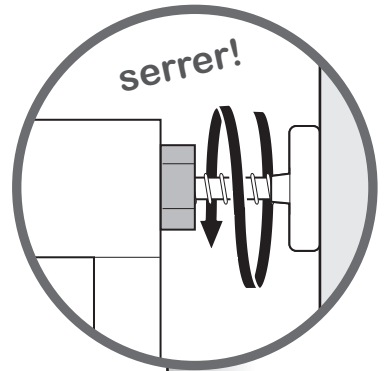

## installation (suite) :

6

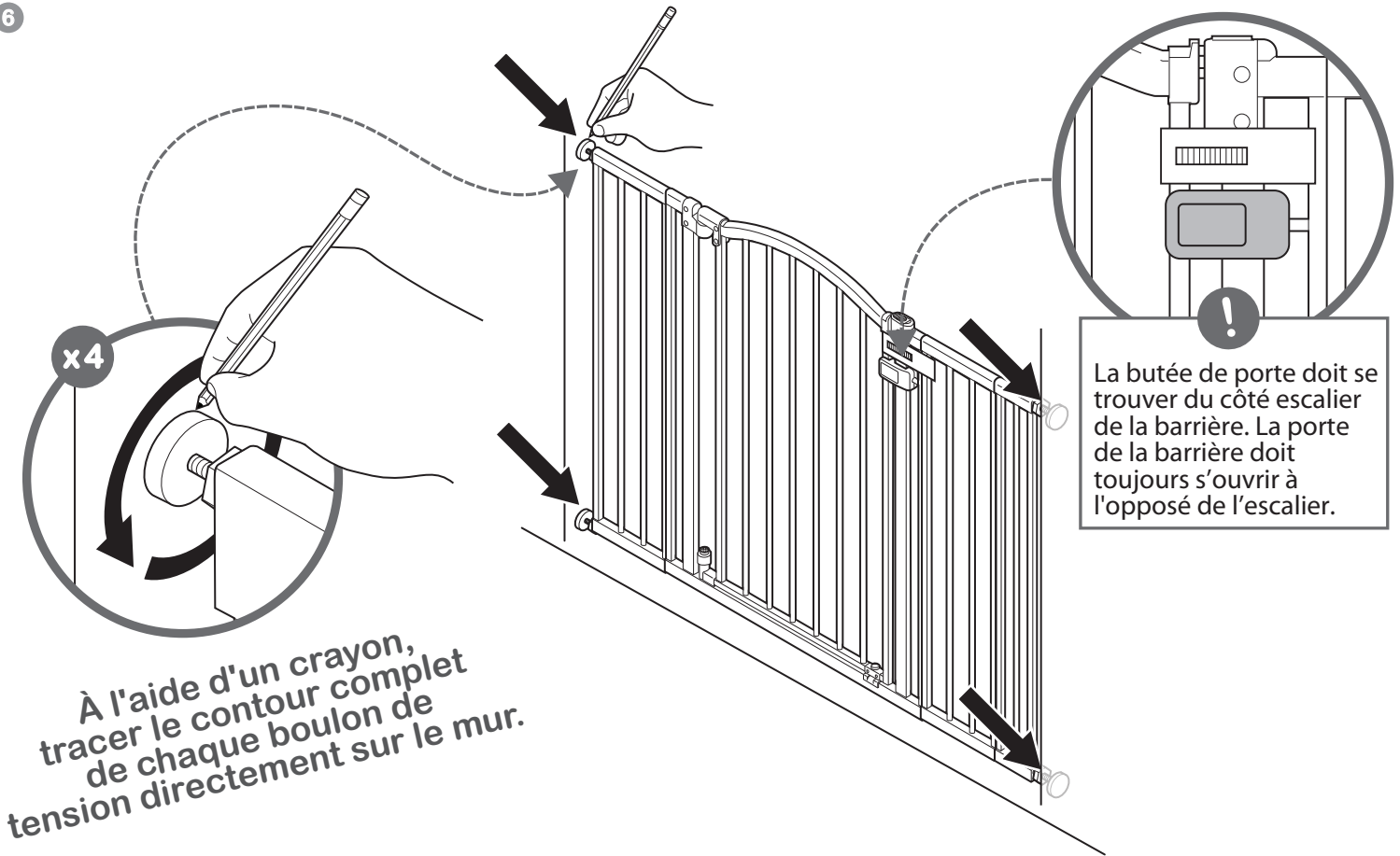

7

Desserrer les écrous de tension inférieurs et supérieurs et retirer la barrière.

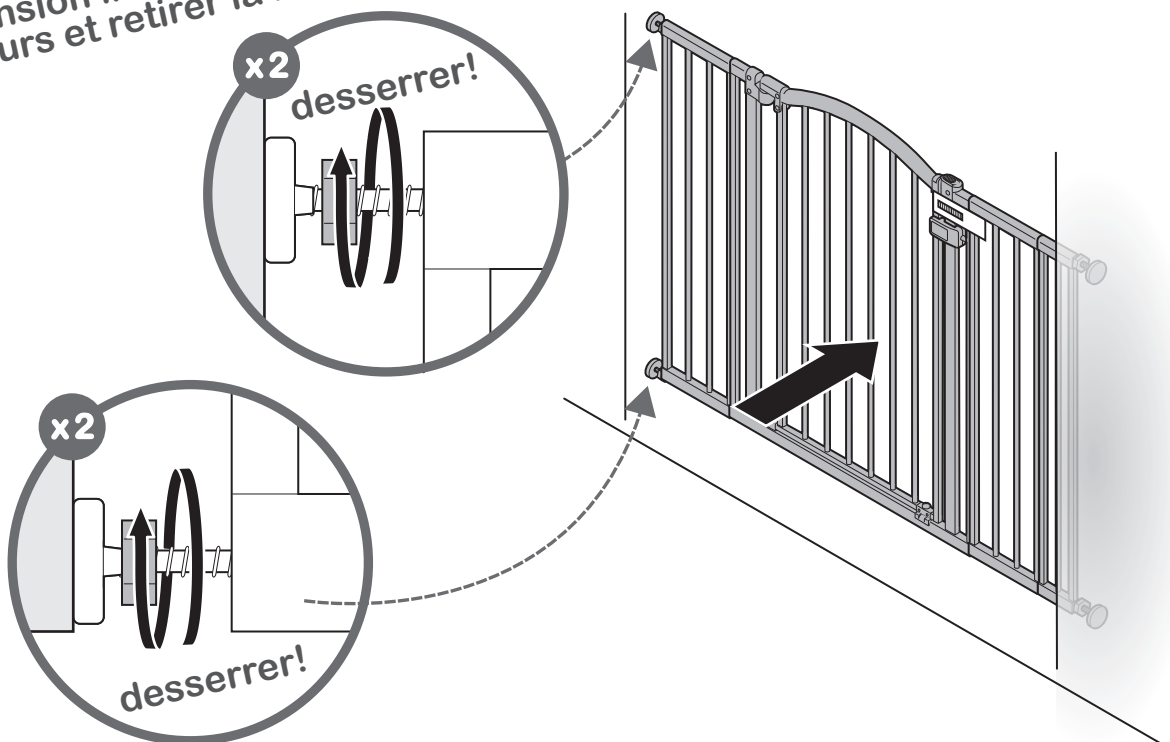

# installation du système de fermeture :

8  
Placer un tampon de protection murale au centre de chaque contour circulaire sur le mur.

## ! MISE EN GARDE

l'installation des coupelles murales est **OBLIGATOIRE** pour une utilisation en haut des escaliers.

Marquer les orifices de perçage avec un crayon à travers le centre de chaque tampon de protection.

x4

## ! IMPORTANT

Au sommet du palier, installer la barrière au minimum de 8 à 15 cm (3 à 6 po) de la marche supérieure.

## ! IMPORTANT

NE JAMAIS ouvrir la porte de la barrière par-dessus les escaliers



9

1<sup>er</sup>  
Perçer un trou pilote de 0,56 cm (7/32 po) dans chacune des 4 marques centrales.

!  
**Remarque :** En cas de montage sur du plâtre ou une cloison sèche, suivre cette étape et utiliser les ancrages muraux fournis.

2<sup>e</sup>  
Insérer les ancrages muraux dans les trous pilotes.

M  
x4

## installation du système de fermeture :



10

Visser les tampons  
de protection  
murale dans le mur.

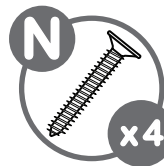
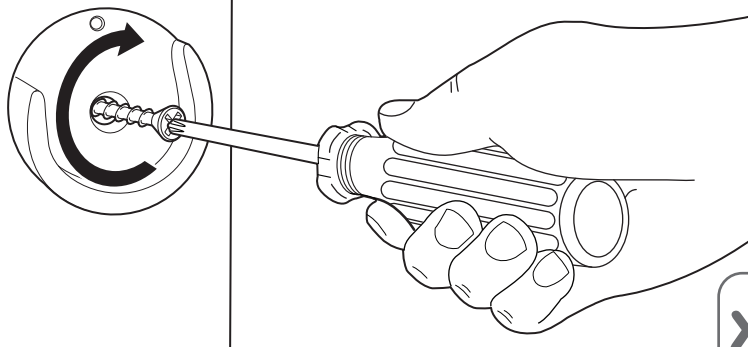

x4

11

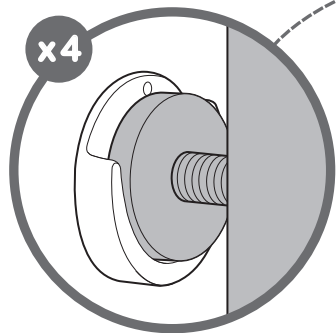

Répéter les étapes  
d'installation de la page 5.  
Les 4 boulons de tension  
reposeront à l'intérieur  
de chaque tampon  
de protection murale.

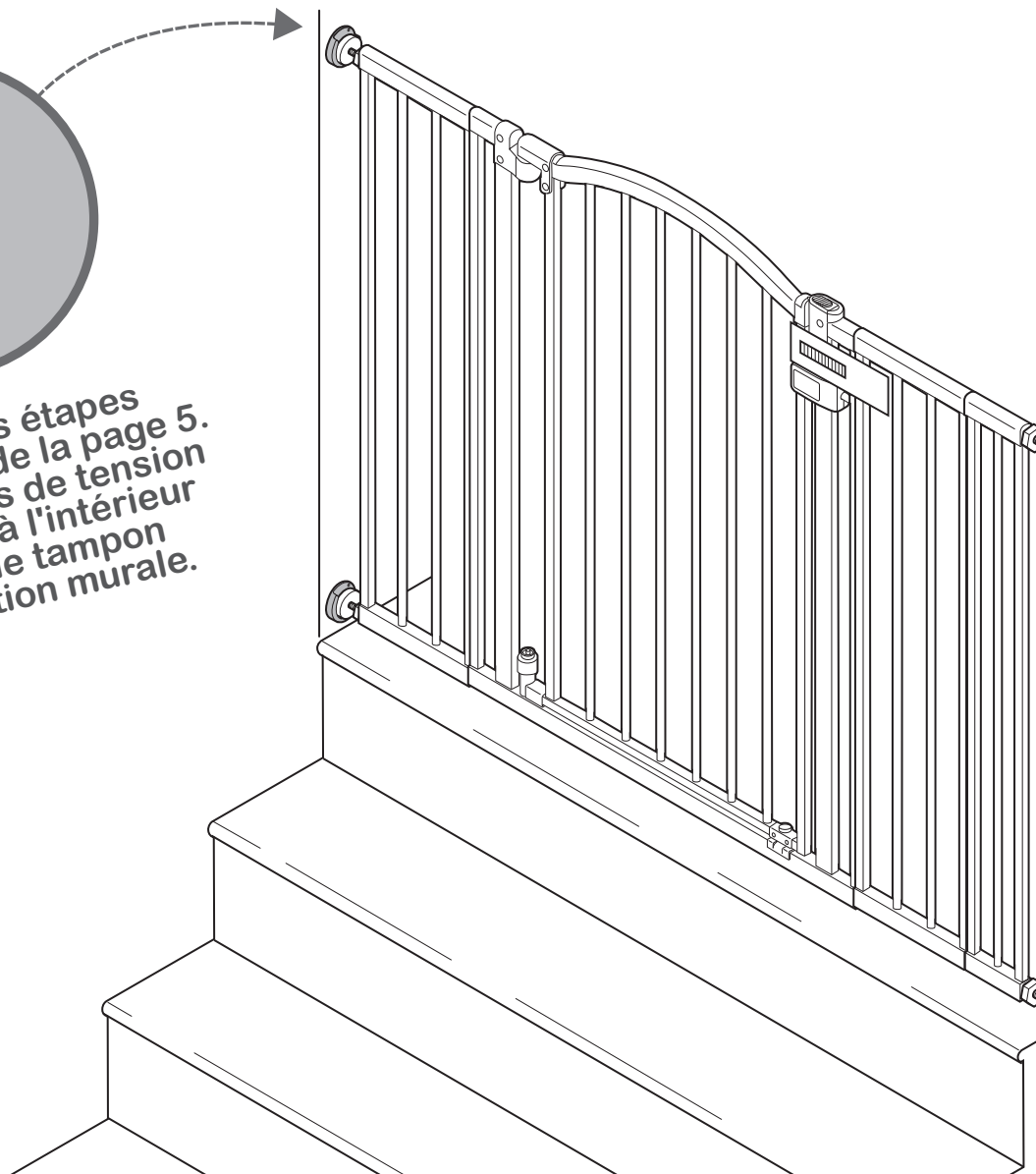

## installation du système de fermeture :

12

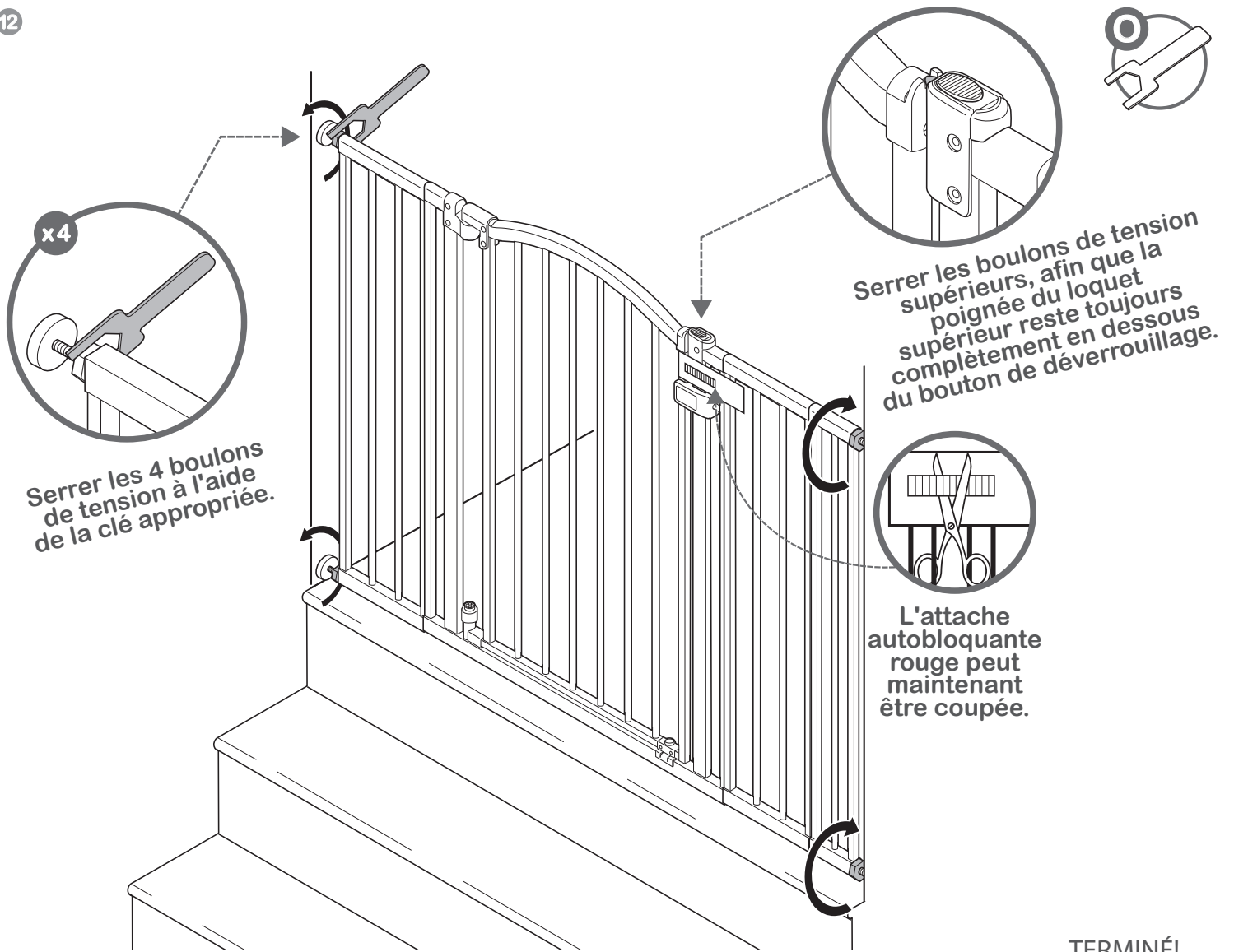

## installation du montage par pression :

1

**1<sup>er</sup>**  
Enlever la pellicule protectrice sur un des côtés de chaque coussinet de montage adhésif.

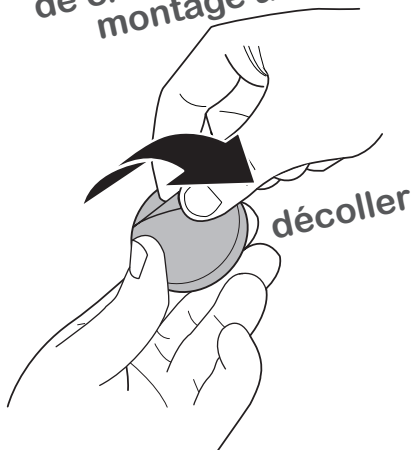

**2<sup>e</sup>**  
Fixer un coussinet au dos de chaque tampon de protection murale.

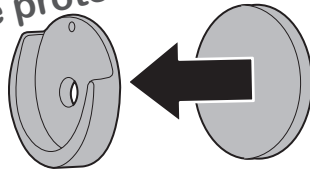

**3<sup>e</sup>**  
Retirer la pellicule protectrice.

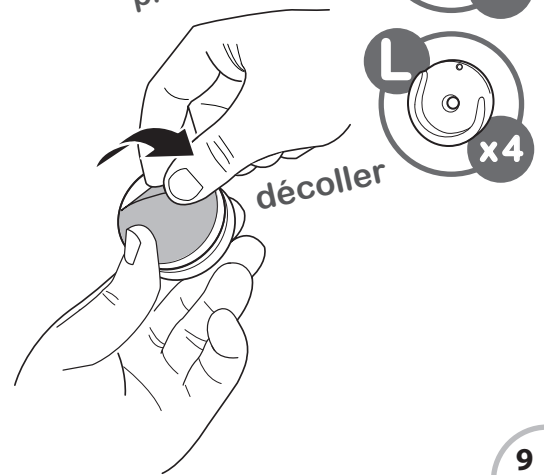

2

Placer les tampons de protection murale face vers le haut dans le contour murale créé à l'étape 6. Coller les tampons de protection murale sur le mur en les appuyant pendant quelques secondes.

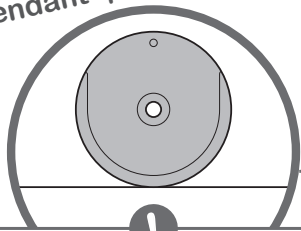

**Remarque :** Les tampons de protection murale inférieurs doivent être au niveau du sol.

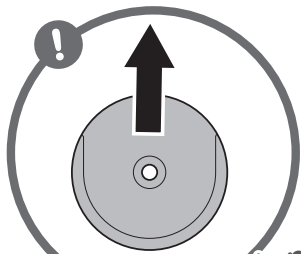

Vérifier que tous les tampons de protection murale soient orientés vers le haut.

appuyer

appuyer

appuyer

appuyer

3

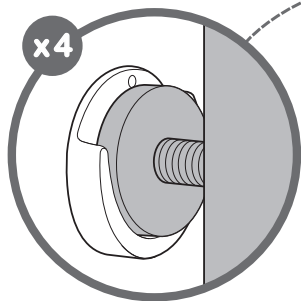

Répéter les étapes d'installation de la page 5. Les 4 boulons de tension reposeront à l'intérieur de chaque tampon de protection murale.

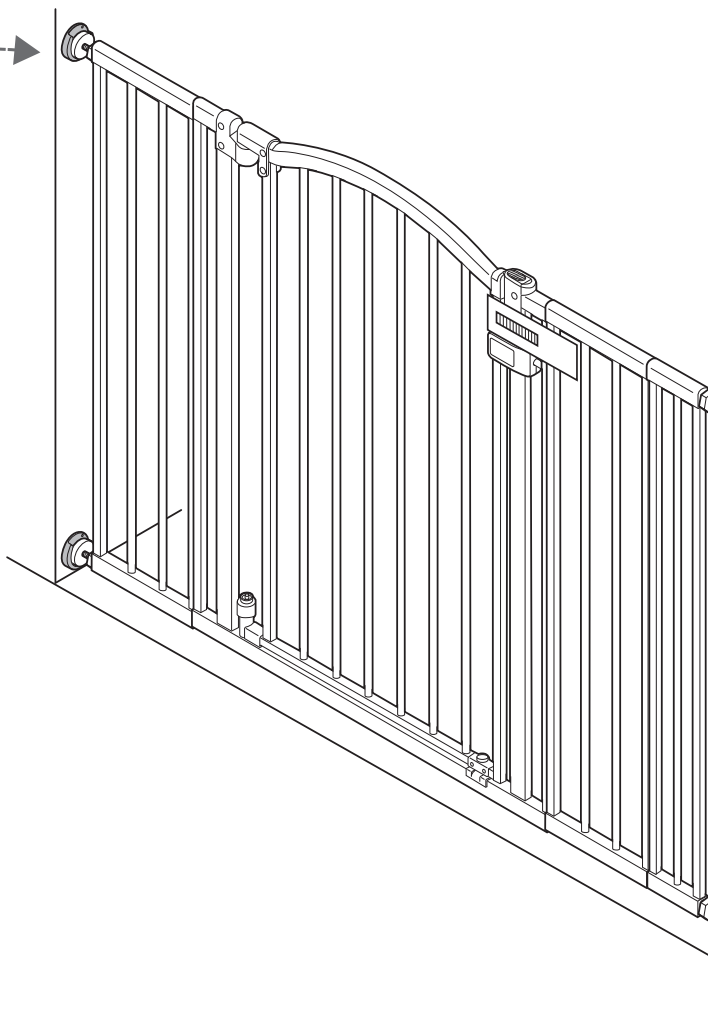

4

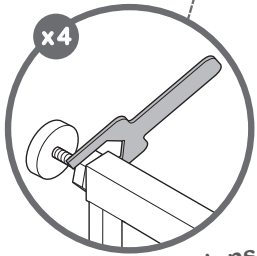

Serrer les 4 boulons de tension à l'aide de la clé appropriée.

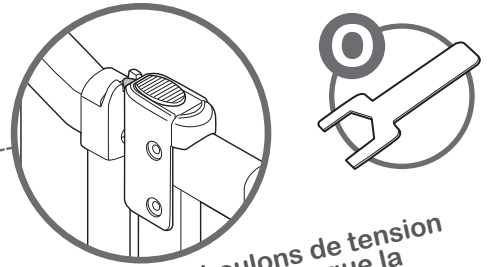

Serrer les boulons de tension supérieurs, afin que la poignée du loquet supérieur reste toujours complètement en dessous du bouton de déverrouillage.

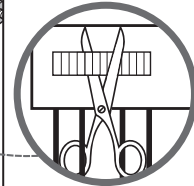

L'attache autobloquante rouge peut maintenant être coupée.

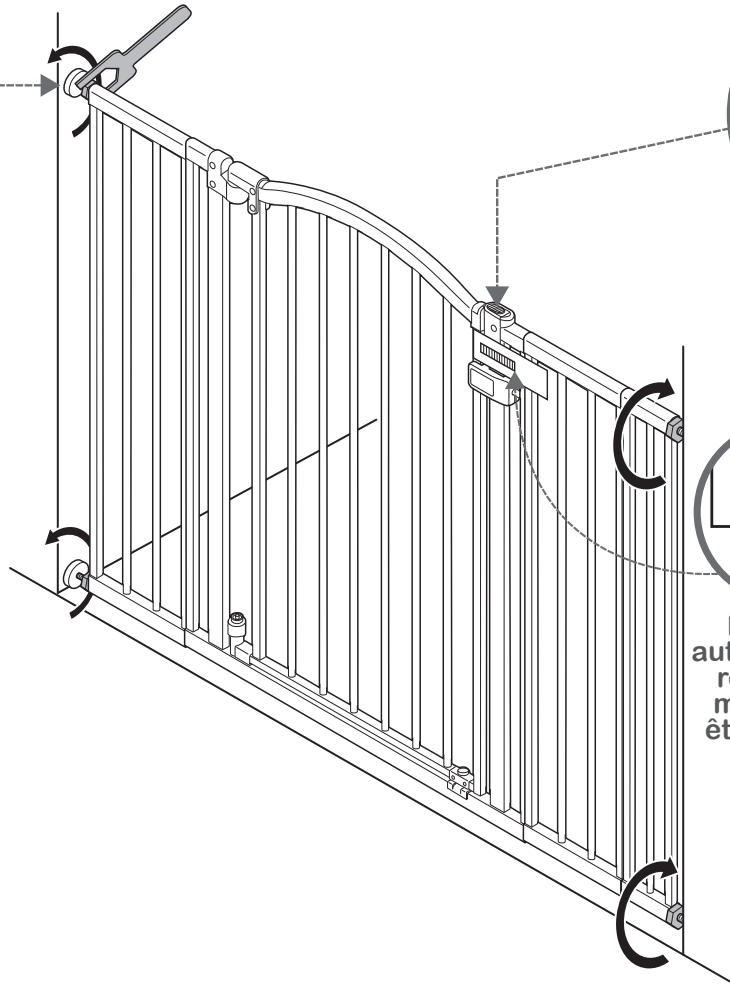

**TERMINÉ!**

### vérification de l'installation :

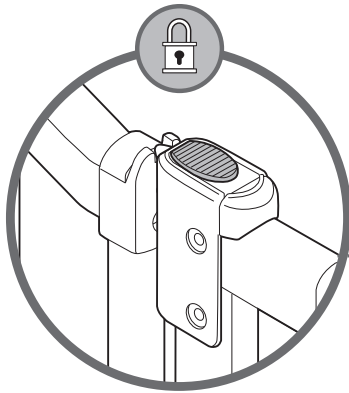

**1<sup>er</sup>**  
Fermer la barrière. S'assurer que les loquets supérieur et inférieur se verrouillent solidement.

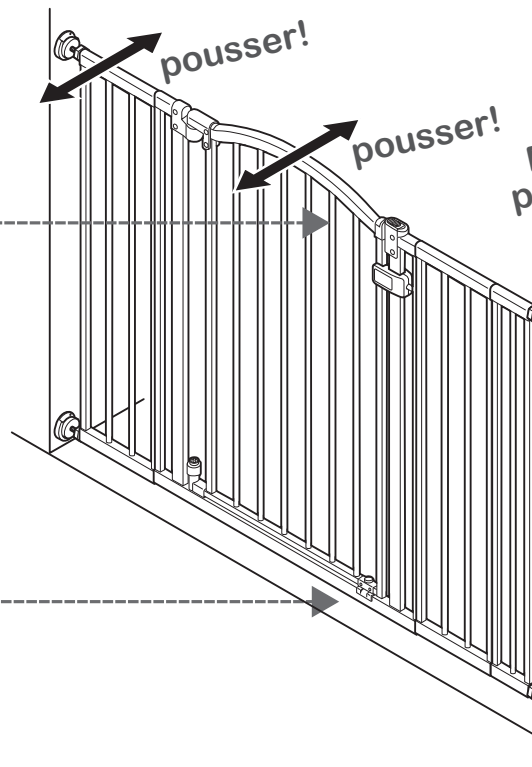

**2<sup>e</sup>**  
Exercer une pression sur la barrière et les cadres d'extension pour vérifier la stabilité.

## fonctionnement :



pour déverrouiller la barrière :

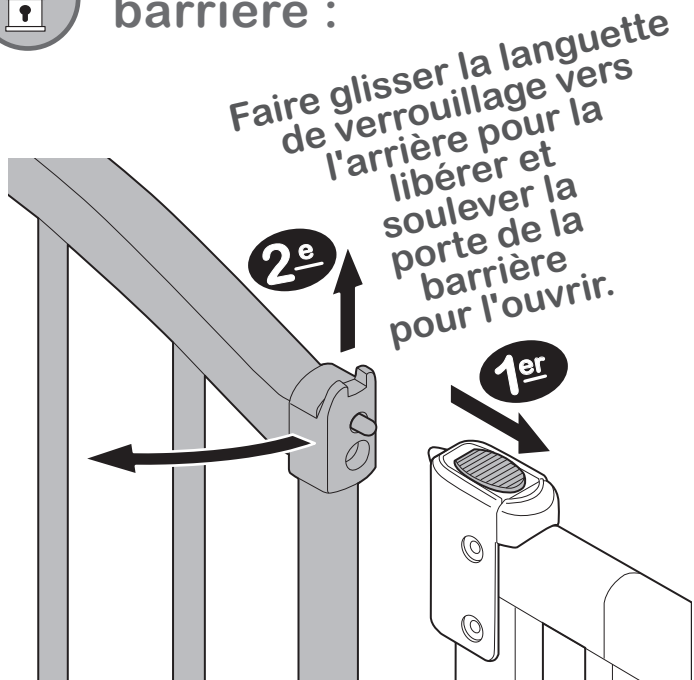

fonction de maintien en position ouverte :

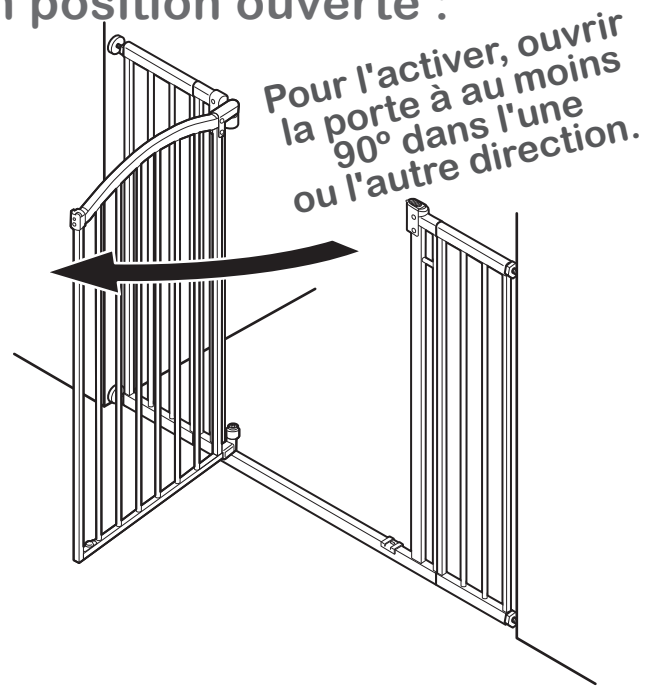

## dépannage :

Si la barrière ne se ferme pas correctement :

**1. La barrière n'est pas correctement alignée dans l'armature de la porte.**

**Solution :** Pour ajuster l'alignement de la barrière, desserrer les quatre boulons de tension et repositionner la barrière pour qu'elle corresponde à l'image « correcte ». Serrer de nouveau les boulons de tension.

**2. La pression des boulons de tension doit être ajustée.**

**Solution :** Desserrer ou resserrer les boulons de tension supérieurs. S'assurer que le loquet supérieur s'enclenche bien lorsque la barrière est fermée et qu'il peut être libéré correctement lorsque la languette de verrouillage est repoussée.

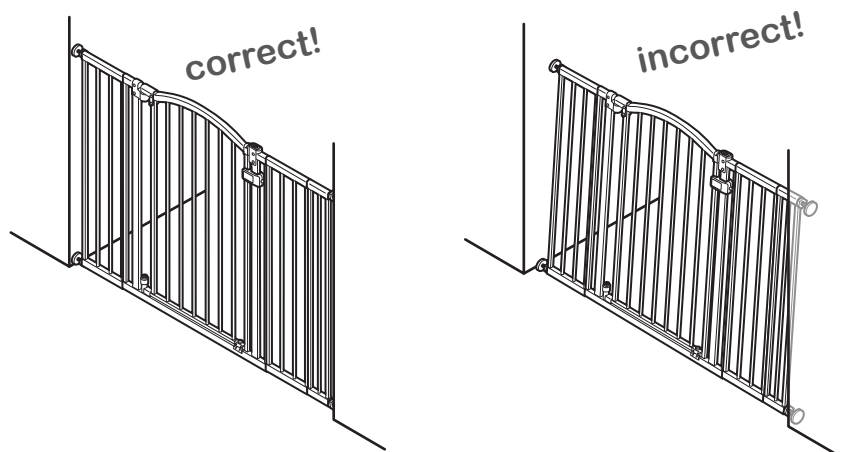

## entretien :

- Vérifier régulièrement les boulons de tension pour s'assurer que la barrière est bien en place.
- Ne pas utiliser la barrière si des pièces sont endommagées ou manquantes.
- Essuyer la surface avec un linge ou une éponge légèrement humectés de savon doux et d'eau tiède.

MANUFACTURED FOR • FABRIQUÉ POUR **kids2™** **OKids II®** ©2024 KIDS2, LLC [www.kids2.com/help](http://www.kids2.com/help)

KIDS2, LLC ATLANTA, GA USA 30305 • 1-800-230-8190

IMPORTED BY • IMPORTÉ PAR

KIDS2 CANADA CO. PO BOX 54059, RPA LAWRENCE PLAZA, TORONTO, ON. M6A 3B7

KIDS2 AUSTRALIA PTY LIMITED CASTLE HILL, NSW AUSTRALIA 2154 • (02) 9894-1855

KIDS2 JAPAN K.K. c/o ARK Outsourcing KK 4-3-5-704, Ebisu, Shibuya-ku, Tokyo, Japan 150-0013 • (03) 5322-6081

KIDS2 UK LTD. GROUND FLOOR, SUITE A1A, BREAKSPEAR PARK, BREAKSPEAR WAY, HEMEL HEMPSTEAD,

HP2 4TZ • +44 01582 816 080

KIDS2 EUROPE BV 5 KEIZERS, KEIZERSGRACHT 287, 1016 ED AMSTERDAM, NETHERLANDS • +31 20 2410934

KIDS2 US MÉXICO S.A. DE C.V. • (55) 5292-8488

MADE IN CHINA • HECHO EN CHINA • FABRIQUÉ EN CHINE

Les couleurs et modèles peuvent varier.

**FABRIQUÉ EN CHINA.**

17172, 17173\_092624





Por favor, lea atentamente las siguientes instrucciones.  
Guarde este manual de instrucciones para referencia futura.

Herramientas necesarias: Destornillador de estrella, taladro  
(para la instalación en la parte superior de la escalera)  
y lápiz (no incluidos), llave (incluida).

Para uso con niños de 6 a 24 meses.

Mantenga las piezas pequeñas fuera del alcance de los niños.

Requiere el montaje hecho por un adulto.

Se adapta a aberturas de 75 a 134,6 cm (29,5 a 53 in) de ancho.

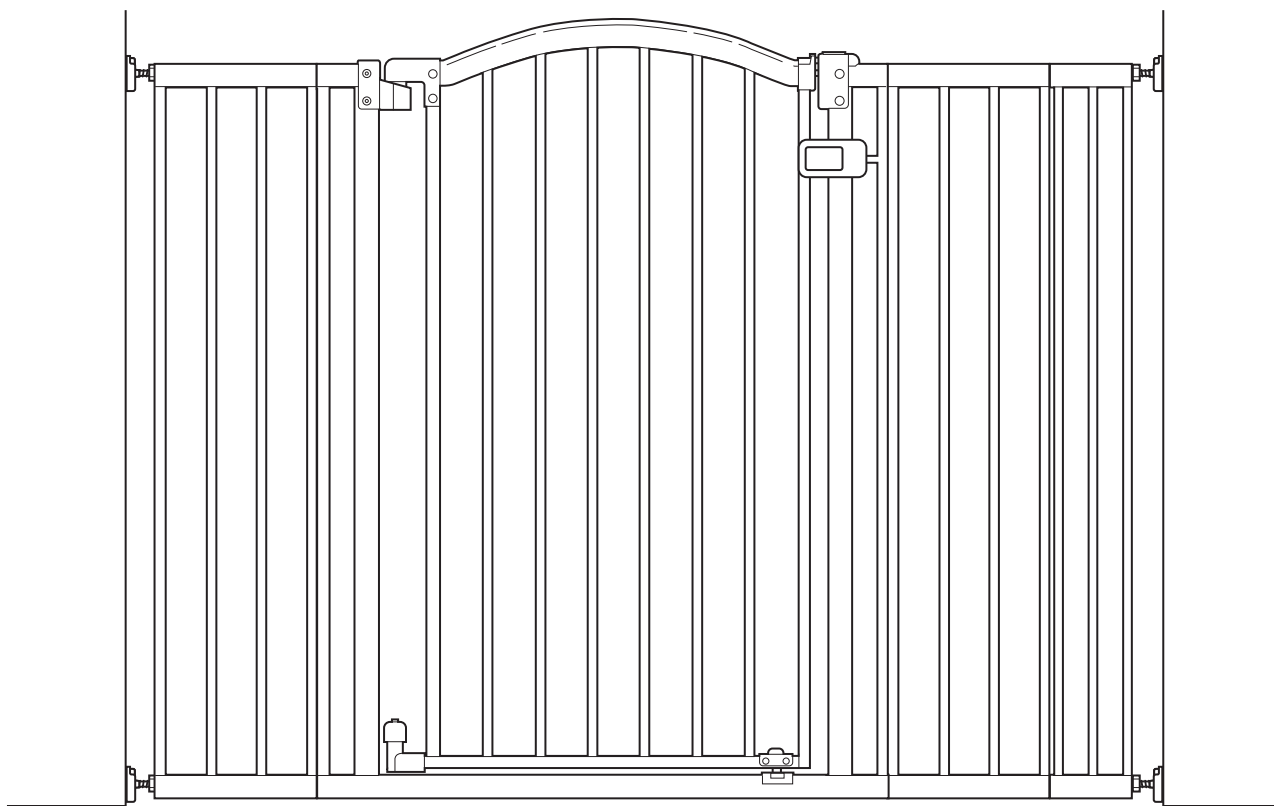

## The Thruway 53W Series™

---

### MANUAL DE INSTRUCCIONES

# ⚠ ADVERTENCIA

Se han producido muertes o lesiones graves en niños cuando las barreras no se instalan correctamente.

- Instale y use **SIEMPRE** la barrera usando todas las partes necesarias, como se indica.
- Instale según las instrucciones del fabricante.
- Deje de usarla cuando un niño pueda subir o desprender la barrera.
- Use solo con el mecanismo de bloqueo/cierre firmemente acoplado.
- Para evitar caídas, no lo utilice nunca en la parte superior de las escaleras sin montar los herrajes de las copas de pared y el tope de puerta.
- **DEBE** instalar las copas de pared para mantener la barrera en su sitio. Sin las copas de pared, el niño puede empujar y escapar.
- **NUNCA** use la barrera para mantener al niño alejado de la piscina.
- **NUNCA** deje al niño sin supervisión.
- Cierre y bloquee **SIEMPRE** la barrera detrás de usted.
- Este producto no evitará necesariamente todos los accidentes. Se requiere la supervisión de un adulto en todo momento.
- No utilice si falta algún componente o está dañada.
- Requiere el montaje hecho por un adulto. Tenga cuidado al desembalar y montar el producto.

**⚠ PRECAUCIÓN:** MANTENGA LAS PIEZAS PEQUEÑAS FUERA DEL ALCANCE DE LOS NIÑOS.

## componentes:

**NOTA:** NO corte la brida roja hasta que se le indique

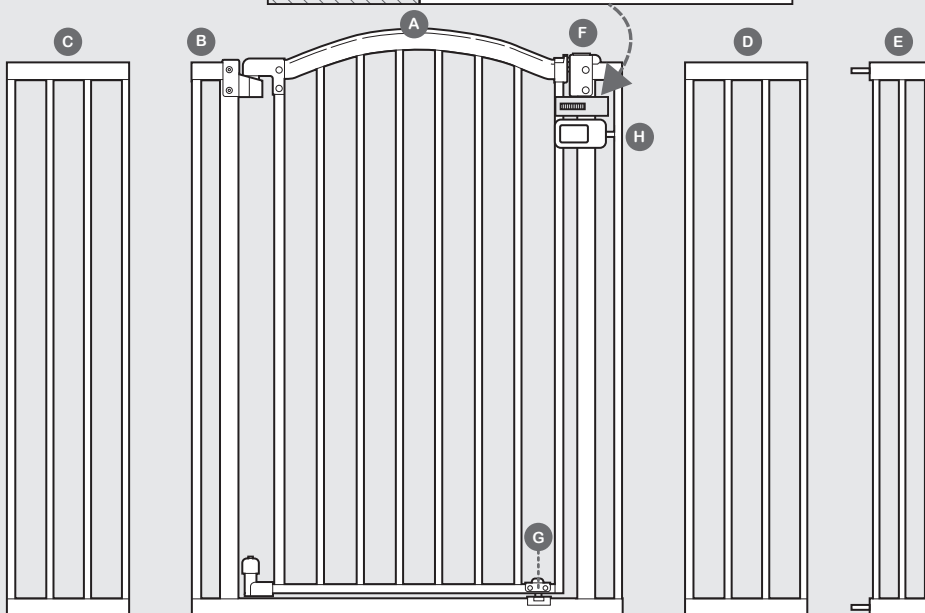

- |                                      |   |                        |
|--------------------------------------|---|------------------------|
| <b>A</b> Puerta de la barrera        | <b>G</b> Cierre inferior                              | <b>M</b> Tornillos (4) |
| <b>B</b> Marco de la barrera         | <b>H</b> Tope de barrera                              | <b>N</b> Llave         |
| <b>C</b> Marco de extensión grande 1 | <b>I</b> Pernos de tensión con tuercas de tensión (4) |                        |
| <b>D</b> Marco de extensión grande 2 | <b>J</b> Almohadillas adhesivas de montaje (4)        |                        |
| <b>E</b> Marco de extensión pequeño  | <b>K</b> Copas de pared (4)                           |                        |
| <b>F</b> Cierre superior             | <b>L</b> Anclajes de pared (4)                        |                        |

## herrajes:

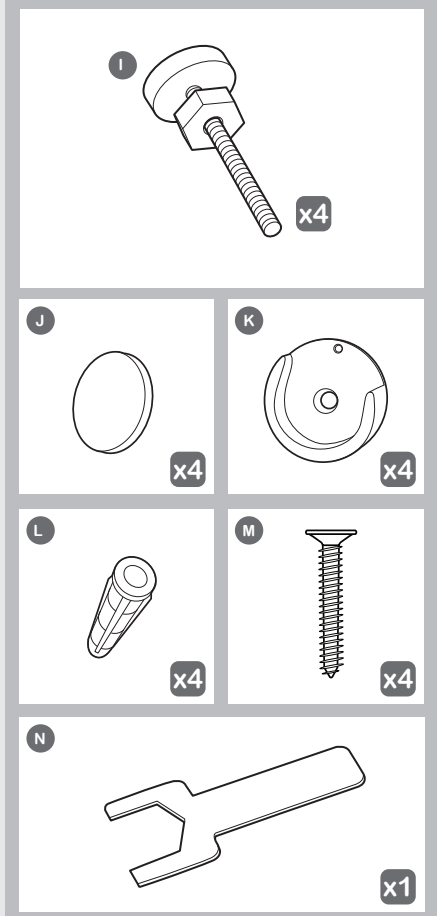

# configuraciones de barrera (elija la que mejor se adapte a su situación):



Mida la anchura de la abertura donde piensa instalar la barrera. Consulte las siguientes ilustraciones para determinar la configuración correcta de instalación. Las molduras de zócalo pueden cambiar la configuración adecuada.

## ⚠️ ADVERTENCIA

NUNCA instale tres marcos de extensión en el mismo lado de la barrera.

**A**

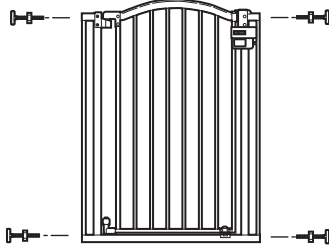

[75 - 84 cm (29,5 - 33 in)] sin marcos de extensión

**B**

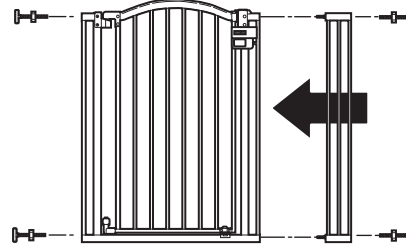

[85 - 94 cm (33,5 - 37 in)] con marco de extensión pequeño

**C**

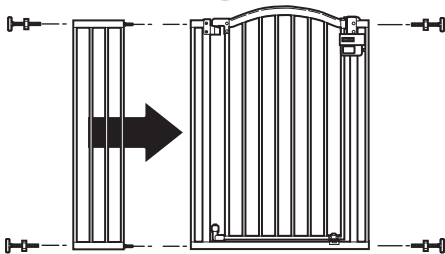

[95,3 - 104 cm (37,5 - 41 in)] con marco de extensión grande

**D**

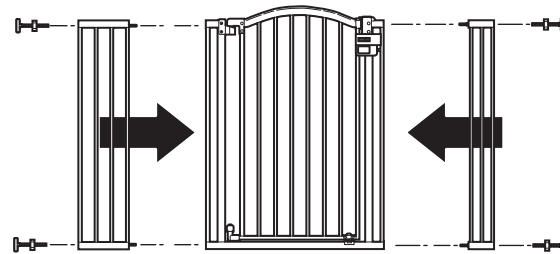

[105,4 - 114,3 cm (41,5 - 45 in)] con marco de extensión grande y pequeño

**E**

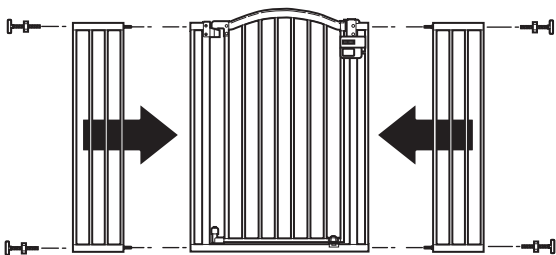

[115,6 - 124,5 cm (45,5 - 49 in)] con 2 marcos de extensión grandes

**F**

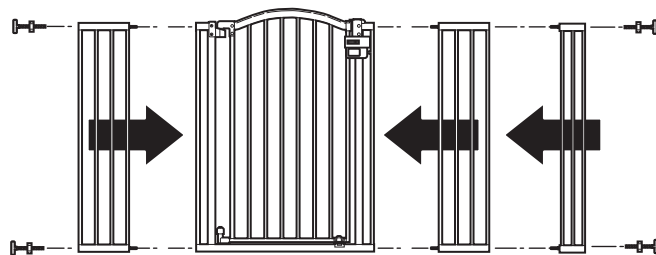

[125,7 - 134,6 cm (49,5 - 53 in)] con 2 marcos de extensión grandes y uno pequeño



**Nota:** Este manual de instrucciones ilustra la instalación de la configuración de barrera F.

Si elige la configuración de barrera A, vaya al paso 2. De lo contrario, siga el paso 1 utilizando los marcos de extensión adecuados que mejor se adapten a su necesidad.



**Importante:** La barrera incluye un tope de puerta (pieza H) que impide que la barrera se abra en una dirección. Cuando instale la barrera en la parte superior de las escaleras, asegúrese de que el tope de la puerta esté en el lado de la escalera de la barrera para que la puerta no pueda abrirse por encima de las escaleras. Aunque el tope de la barrera viene montado en la barrera, puede desmontarse e instalarse a ambos lados del marco de la barrera.

Cuando la barrera no se utiliza en la parte superior de la escalera, el tope de la puerta se puede quitar para permitir que la barrera se abra en cualquier dirección.

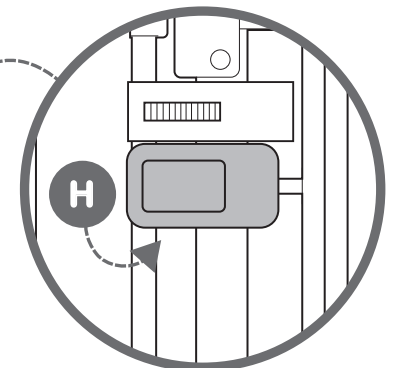

# instalación:

1

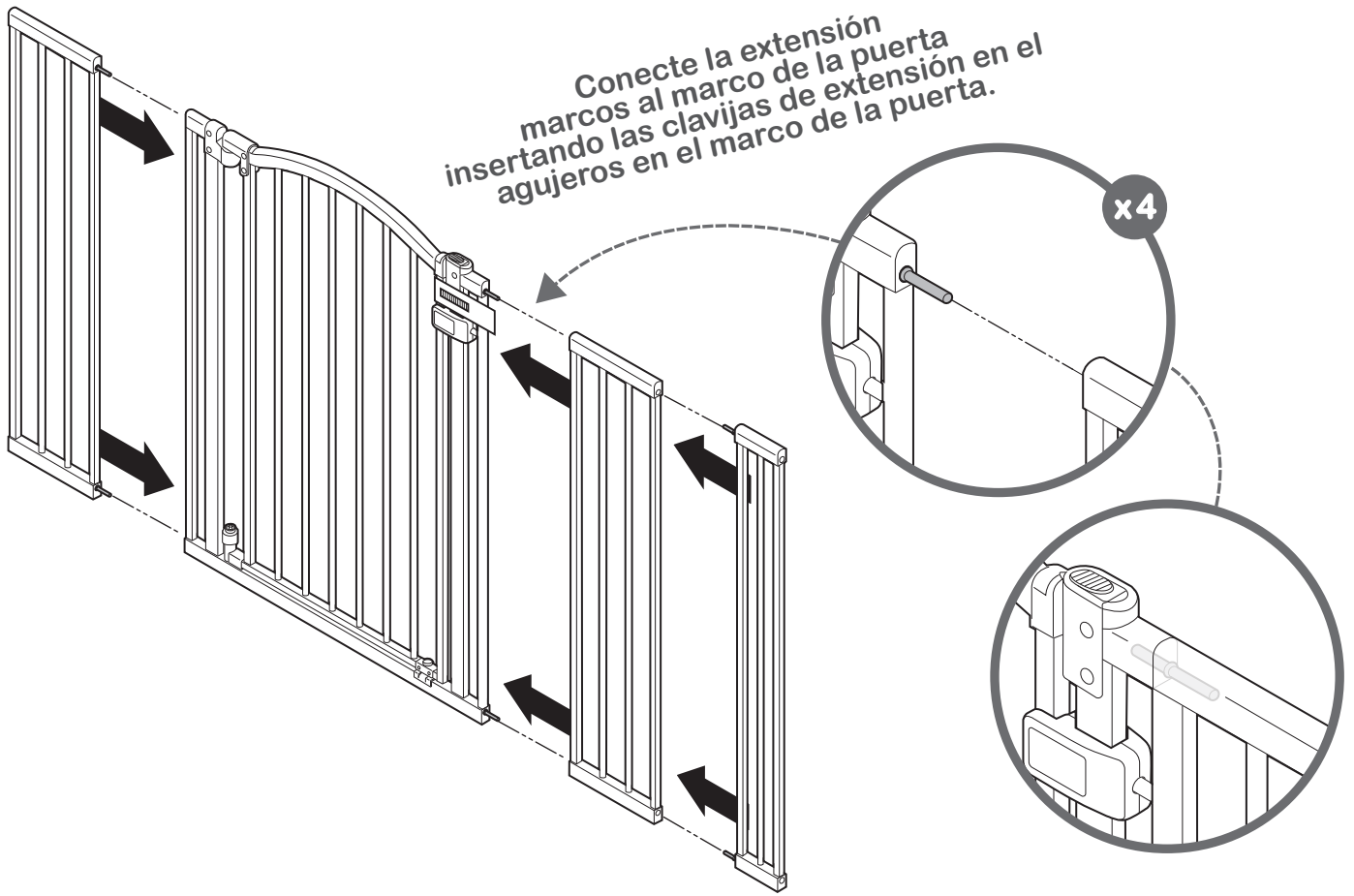

2

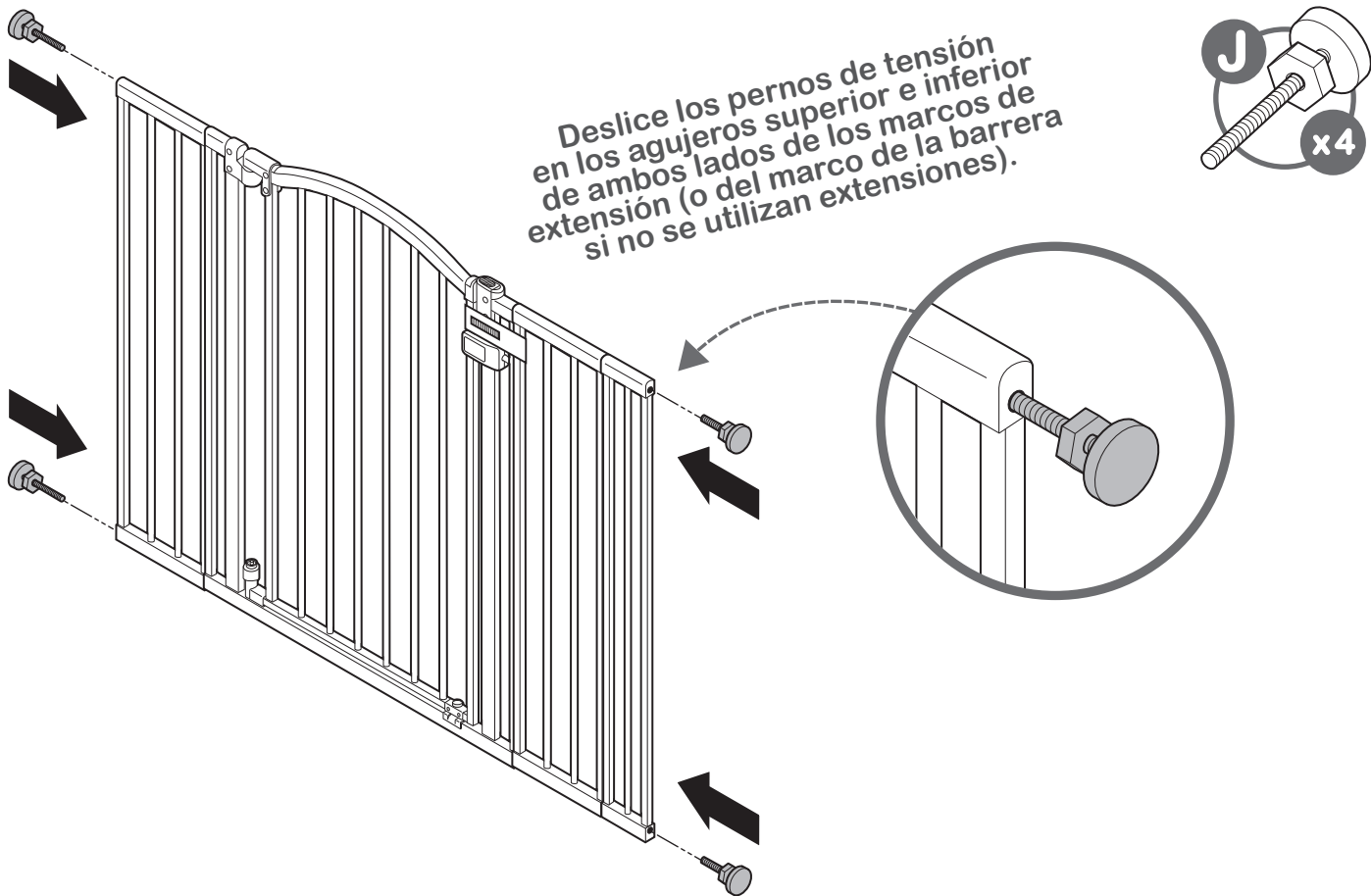

## instalación (continuación):

3

Coloque la barrera en el centro de la abertura. Asegúrese de que la parte inferior de la barrera esté completamente a ras con el piso. Deslice los pernos de tensión hacia fuera hasta que entren en contacto con el marco de la barrera o la pared en ambos lados.

Asegúrese de que el tope de la puerta esté orientado en la dirección deseada. Para el uso en la parte superior de la escalera, el tope de la puerta debe estar en el lado de la barrera que da a la escalera.

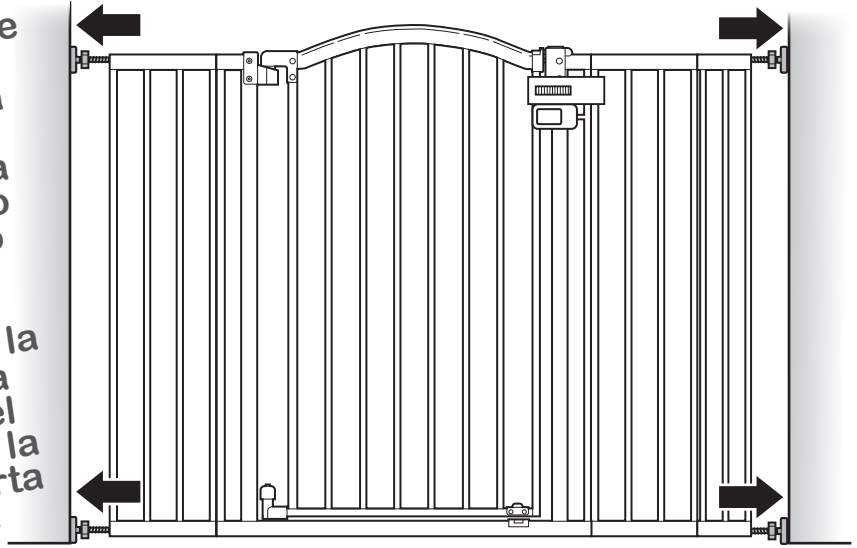

4

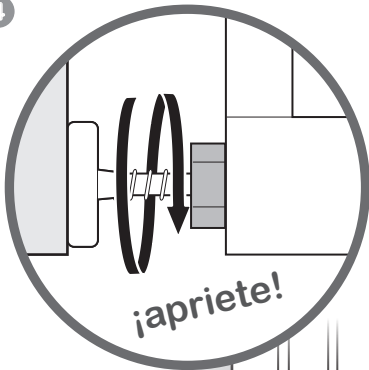

Utilice las tuercas tensoras para apretar los dos pernos de tensión inferiores.

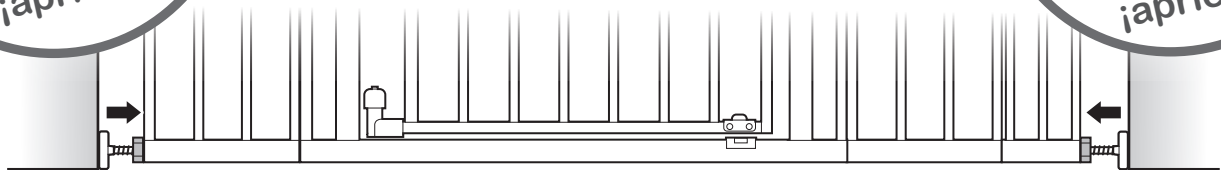
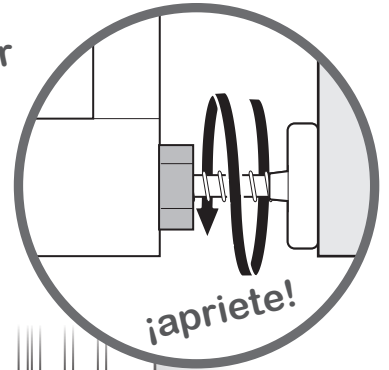

5

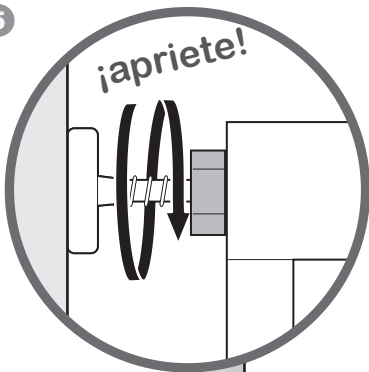

Utilice las tuercas tensoras para apretar los dos pernos de tensión superiores.

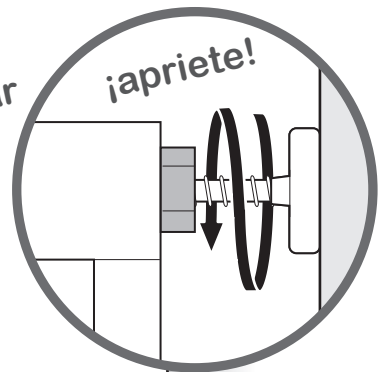

# instalación (continuación):

6

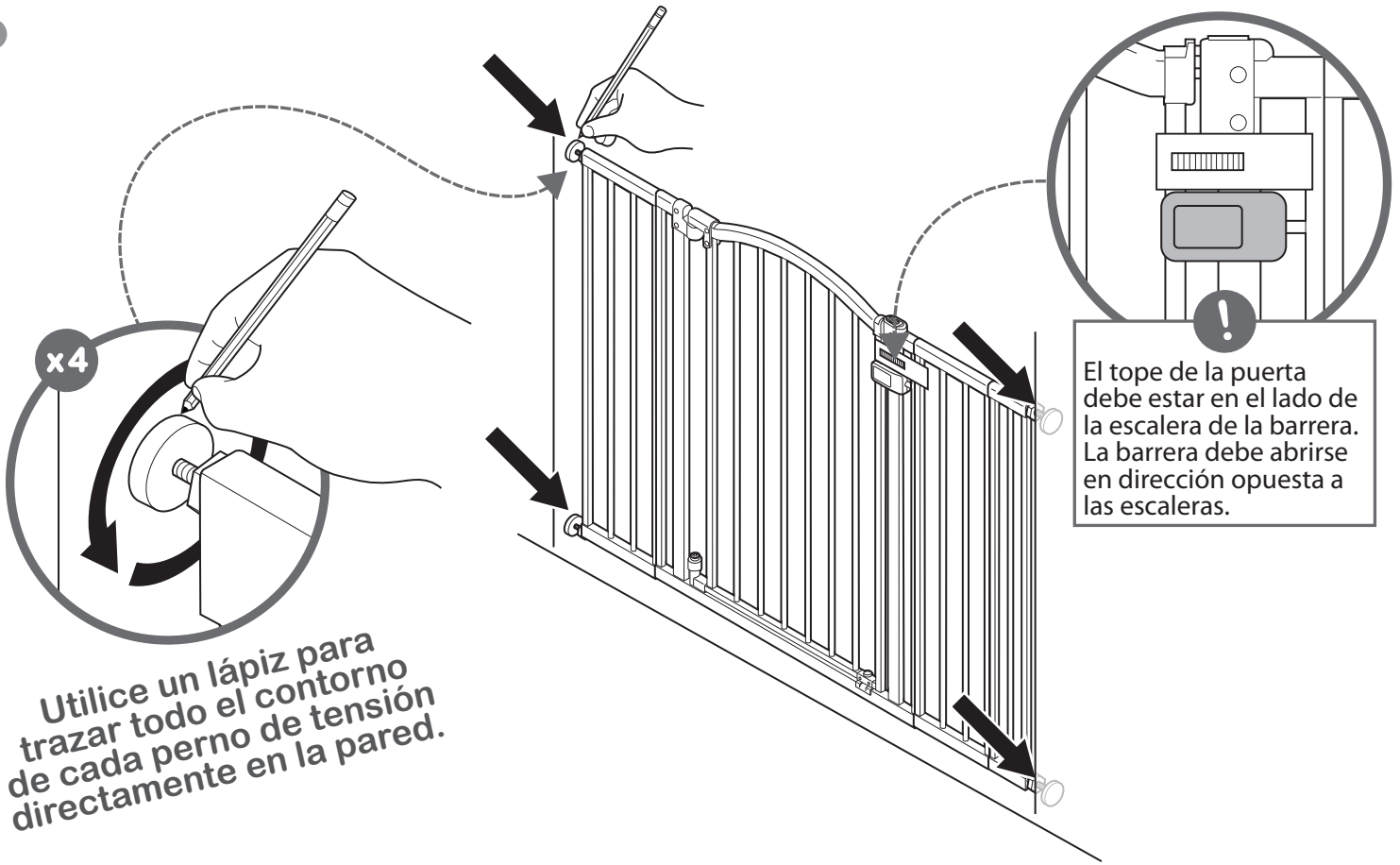

Utilice un lápiz para trazar todo el contorno de cada perno de tensión directamente en la pared.

El tope de la puerta debe estar en el lado de la escalera de la barrera. La barrera debe abrirse en dirección opuesta a las escaleras.

7

Afloje las tuercas de tensión inferior y superior y retire la barrera.

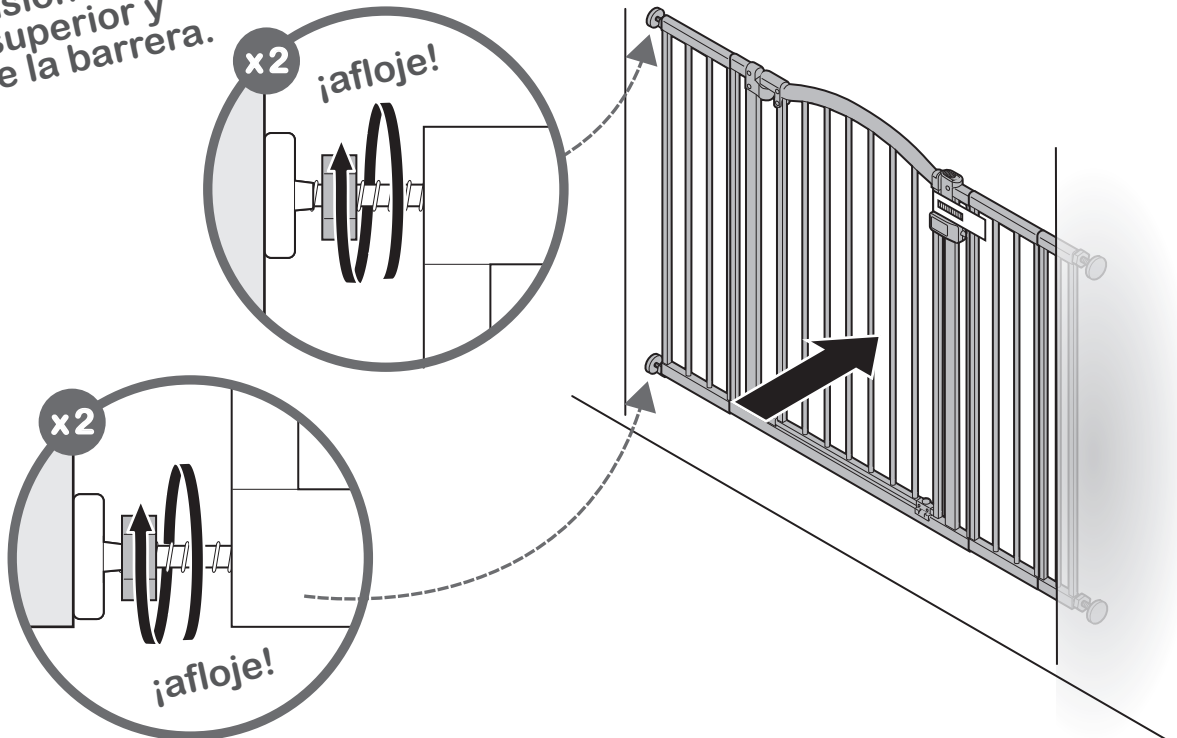

6

# instalación de montaje de los herrajes:

8

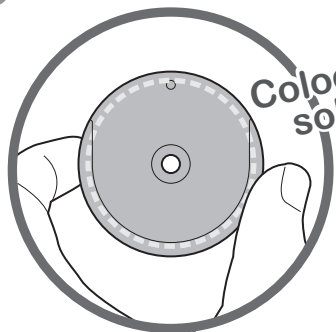

Coloque una copa de pared sobre el centro de cada contorno circular de la pared.

## ! ADVERTENCIA

Si se usa en la parte superior de las escaleras, es OBLIGATORIO montar los herrajes de la copa de pared.

Marque los agujeros de perforación con un lápiz a través del centro de cada copa de pared.

x4

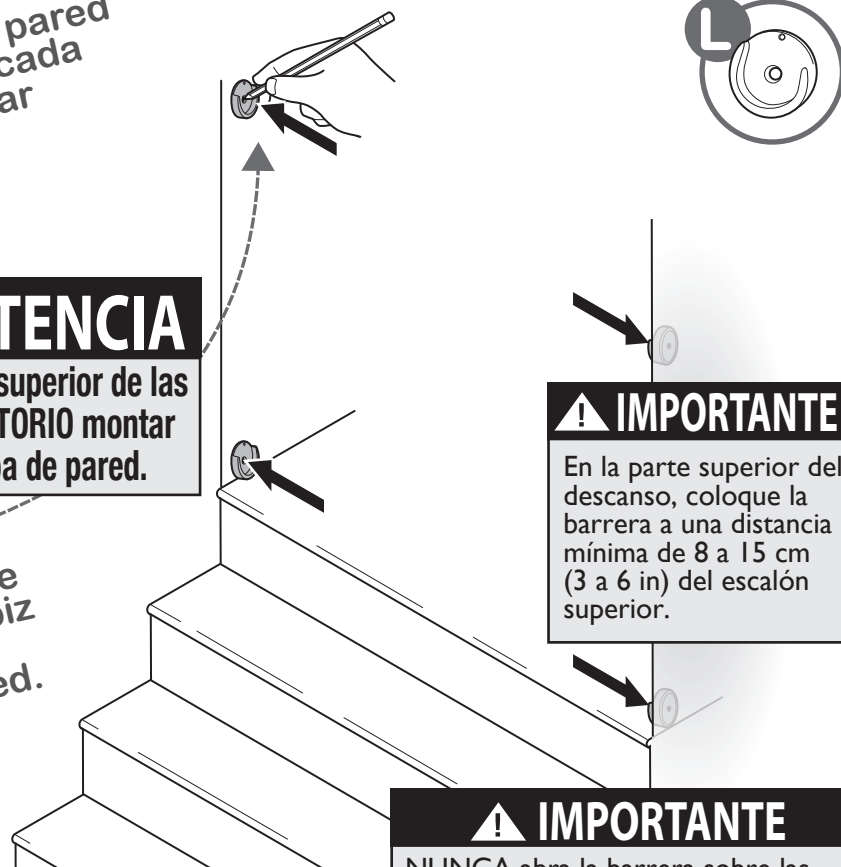

## ! IMPORTANTE

En la parte superior del descanso, coloque la barrera a una distancia mínima de 8 a 15 cm (3 a 6 in) del escalón superior.

## ! IMPORTANTE

NUNCA abra la barrera sobre las escaleras.



9

**1<sup>ro</sup>**  
Taladre un agujero piloto de 5,6 mm (7/32 in) en cada una de las 4 marcas centrales.



**2<sup>do</sup>**  
Inserte los anclajes de pared en los orificios pilotos.



**!**  
**Nota:** Si el montaje se realiza en yeso o paneles de yeso, siga este paso y utilice los anclajes de pared suministrados.

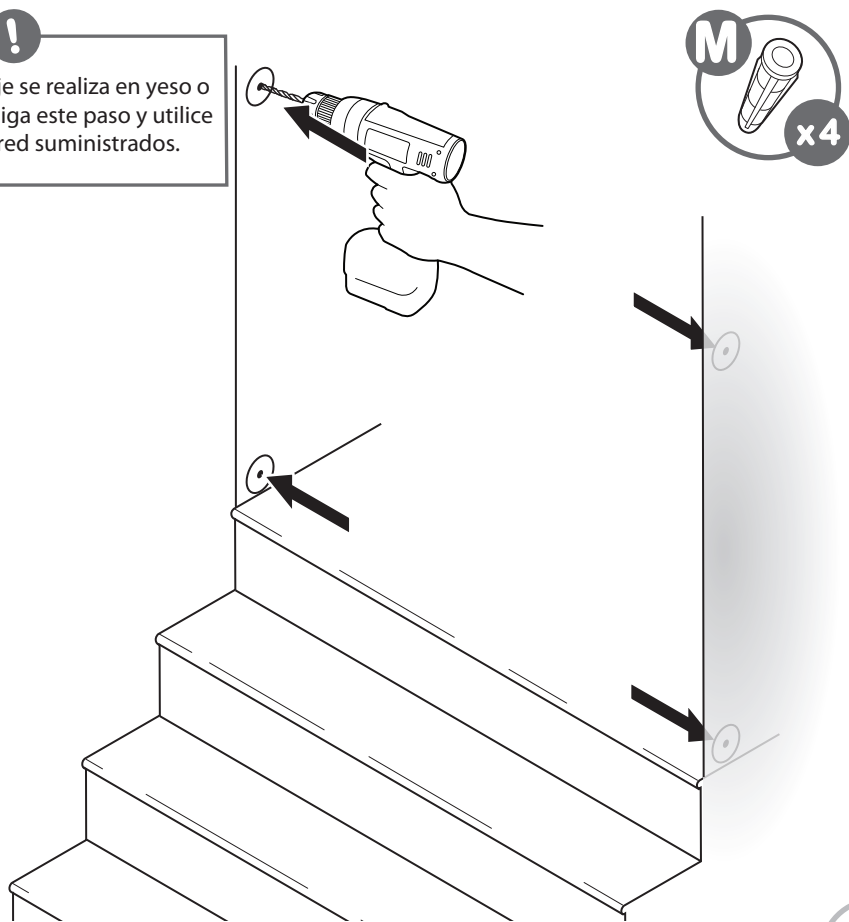

# instalación de montaje de los herrajes:



Atornille las copas a la pared.

10

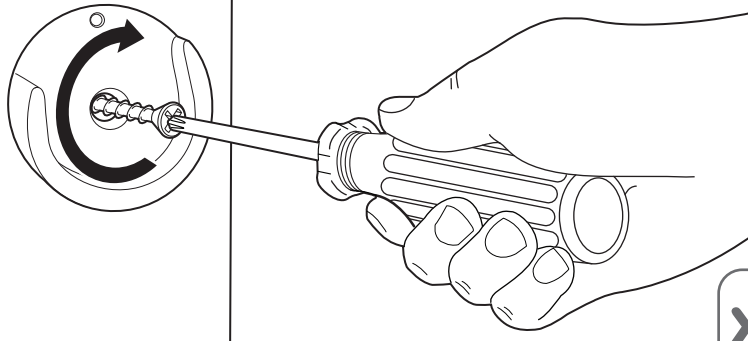

x4

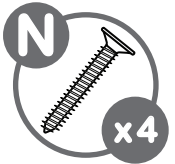

11

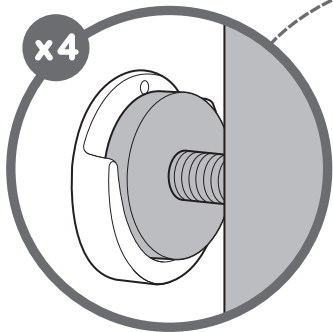

Repita los pasos de "instalación" de la página 5. Los 4 pernos de tensión quedarán dentro de cada copa de pared.

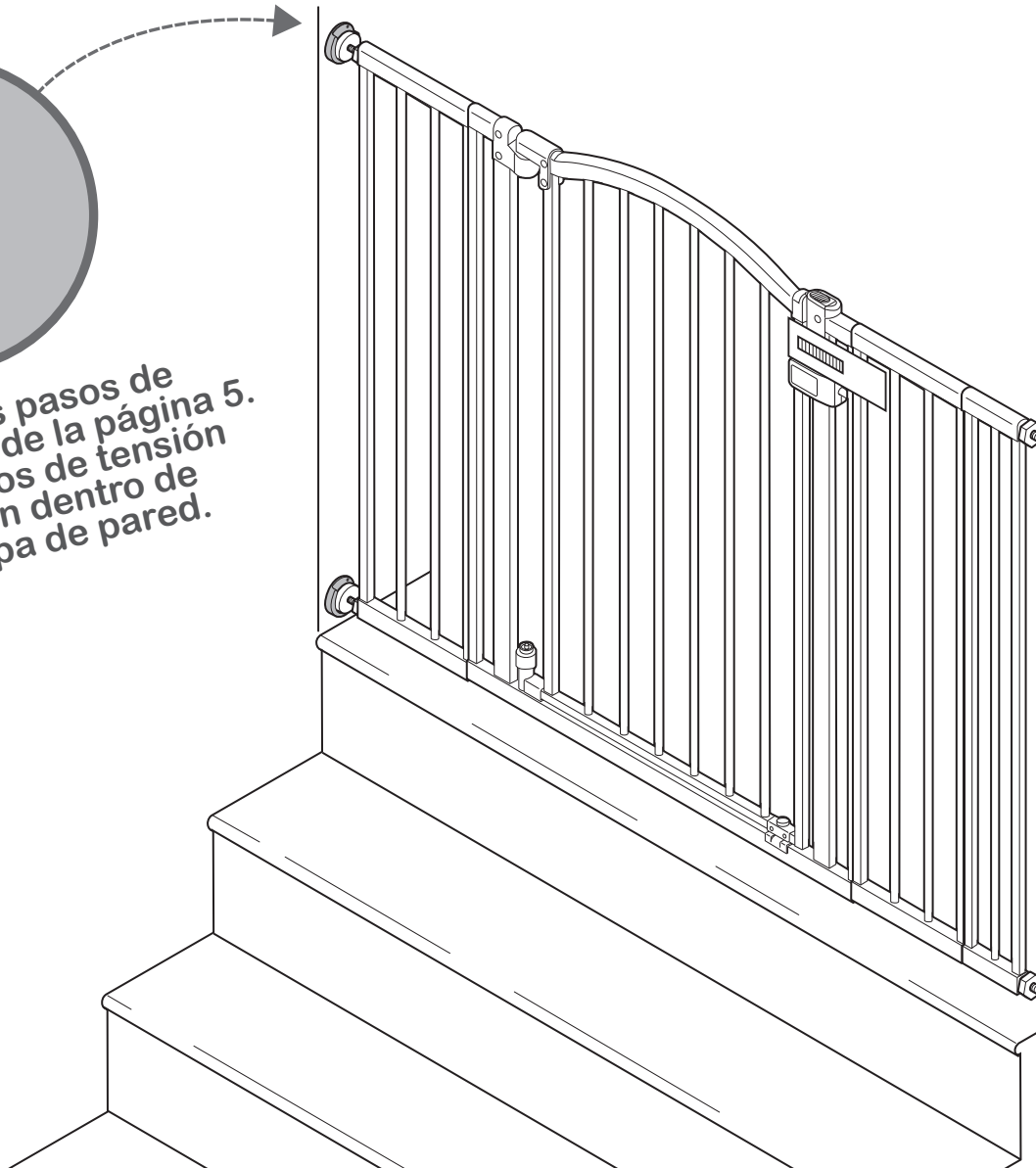



## instalación de montaje de los herrajes:

12

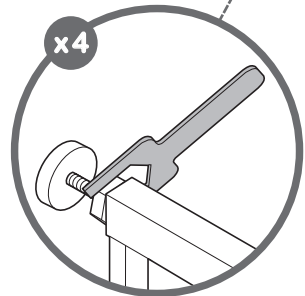

Apriete las 4 tuercas de tensión con la llave suministrada.

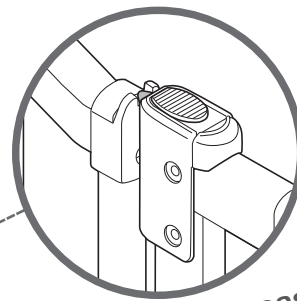

Apriete las tuercas de tensión superiores de modo que el cierre/el asa superior quede completamente por debajo del botón de desbloqueo.

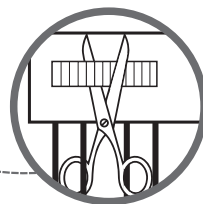

Ahora puede cortar la brida roja.

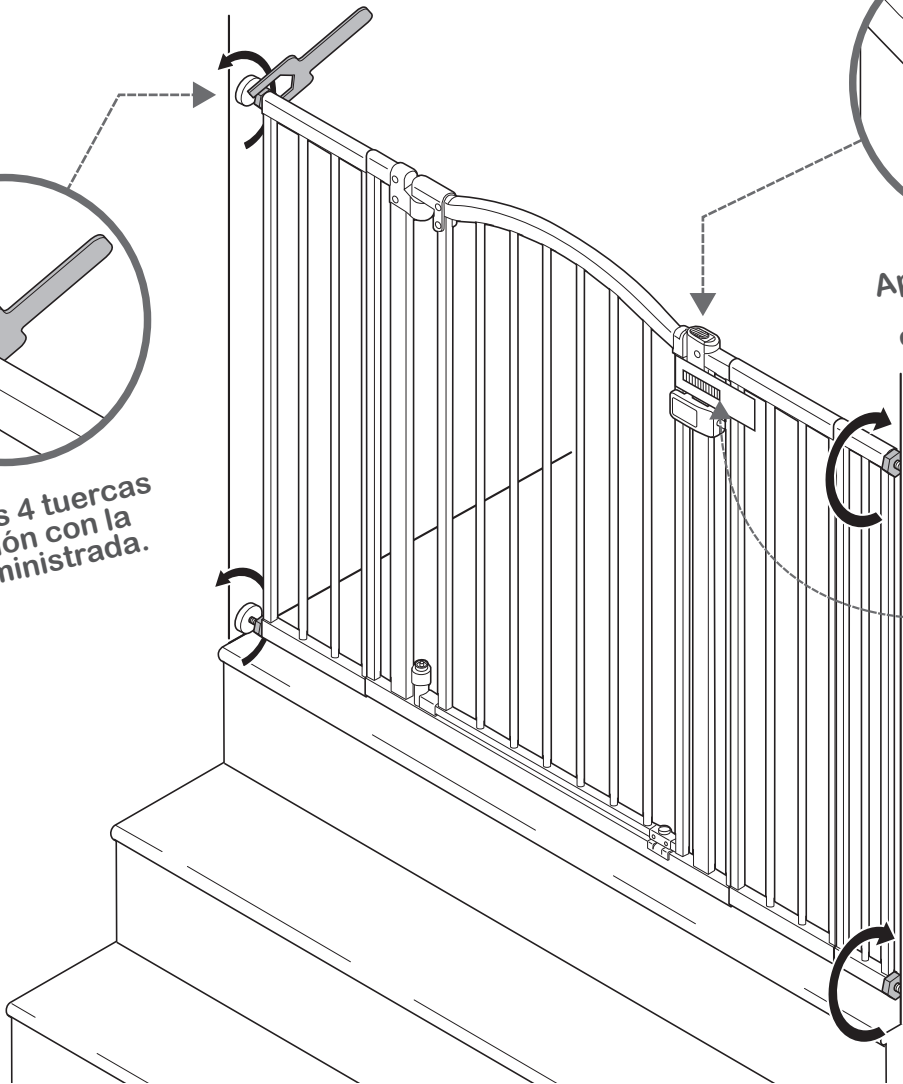

¡TERMINÓ!

## instalación de montaje a presión:

1

**1<sup>ro</sup>**  
Retire el soporte de un lado de cada almohadilla de montaje adhesiva.

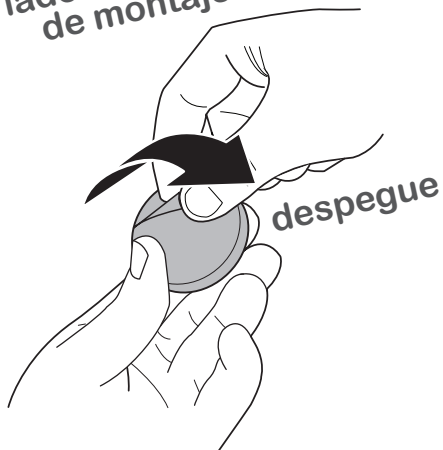

**2<sup>do</sup>**  
Coloque una almohadilla en la parte posterior de cada copa de pared.

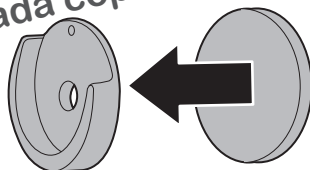

**3<sup>ro</sup>**  
Retire la película protectora.

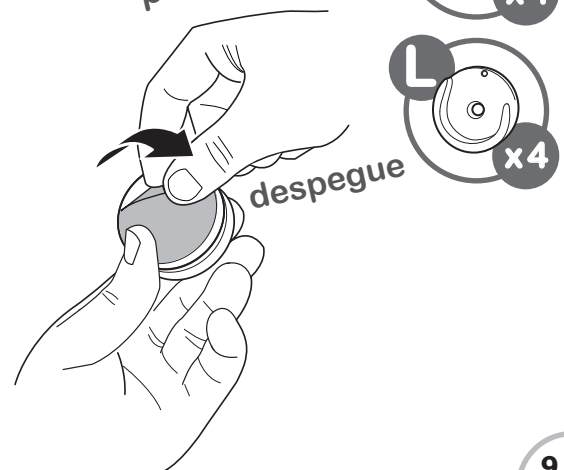

2

Coloque las copas de pared hacia arriba en el dibujo creado en el paso 6. Pegue las copas a la pared y sujételas durante varios segundos.

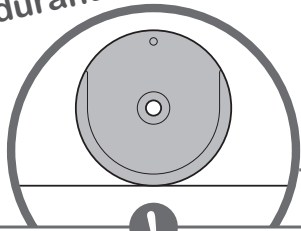

**Nota:** Las copas de la pared inferior deben apoyar en el suelo.

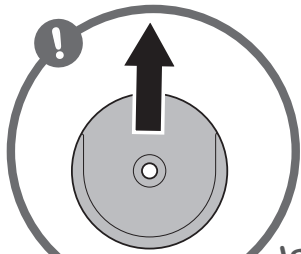

Asegúrese de que todas las copas de pared estén hacia arriba.



3

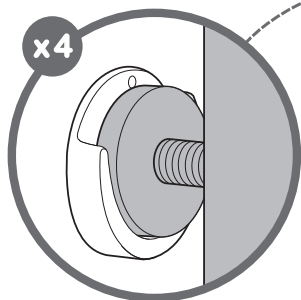

Repita los pasos de "instalación" de la página 5. Los 4 pernos de tensión quedarán dentro de cada copa de pared.

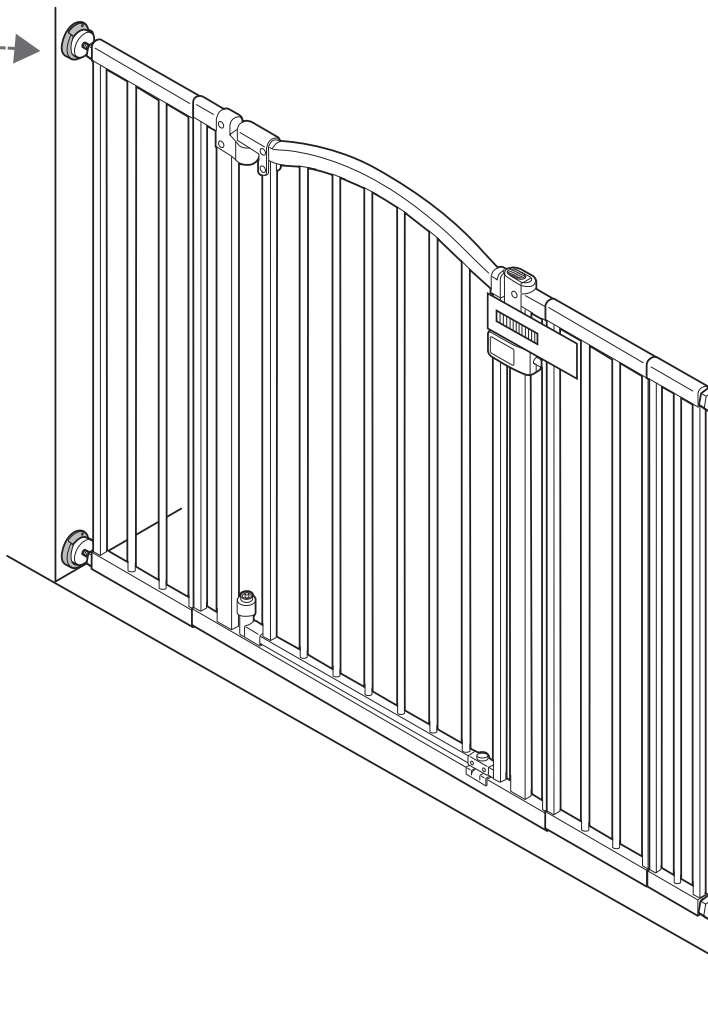

4

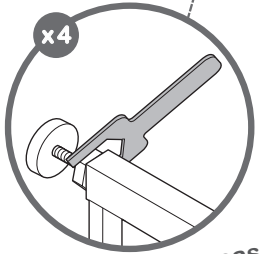

Apriete las 4 tuercas de tensión con la llave suministrada.

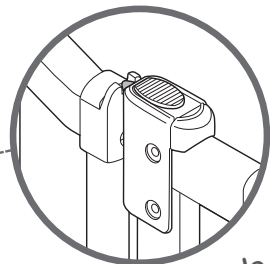

Apriete las tuercas de tensión superiores de modo que el cierre el asa superior quede completamente por debajo del botón de desbloqueo.

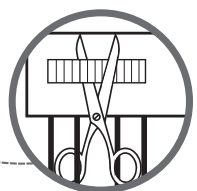

Ahora puede cortar la brida roja.

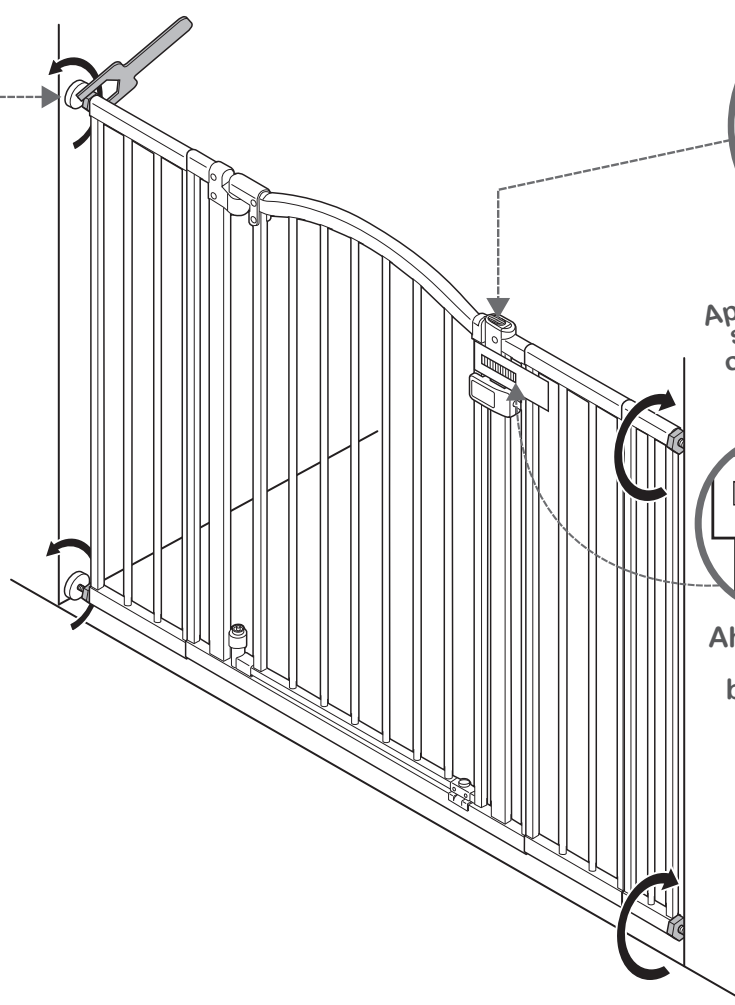

¡TERMINÓ!

comprobación de la instalación:

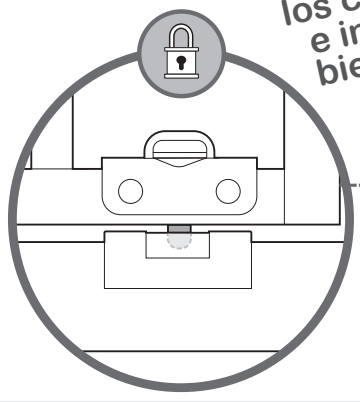
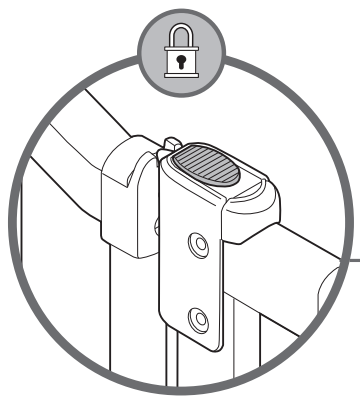

1<sup>ro</sup>

Asegúrese de que los cierres superior e inferior queden bien bloqueados.

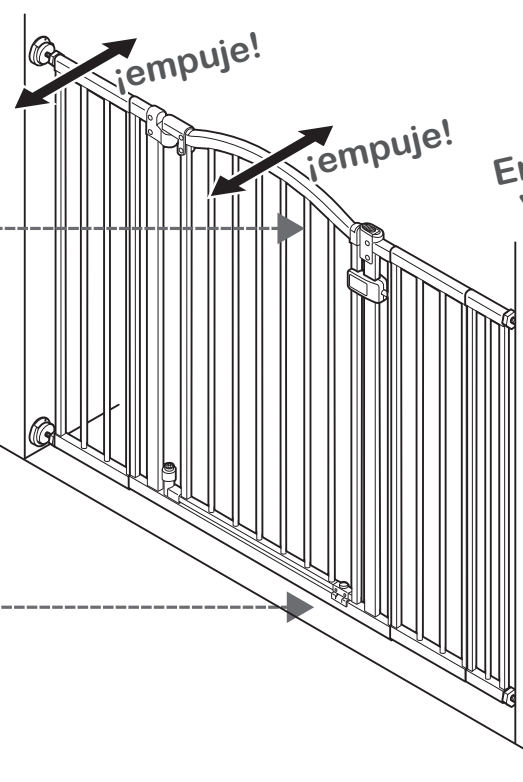

¡empuje!

¡empuje!

2<sup>do</sup>

Empuje la barrera y los marcos de extensión para comprobar la estabilidad.

## funcionamiento:



para desbloquear la barrera:

Deslice la lengüeta de bloqueo hacia atrás para soltarla y abra la barrera.

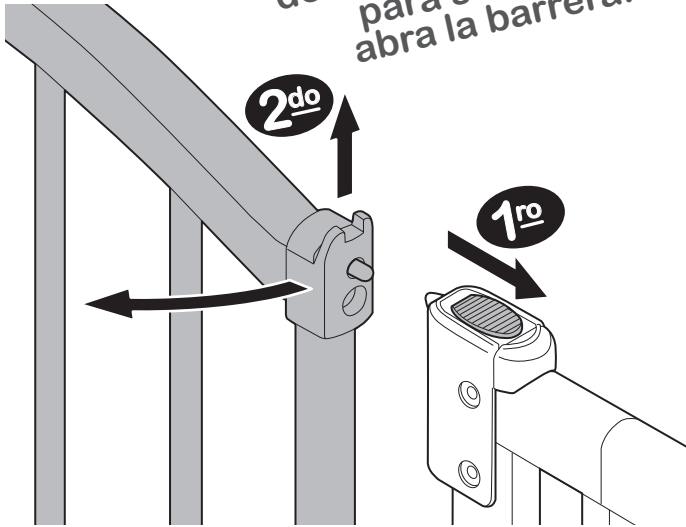

función para mantener la barrera abierta:

Para activarla, abra la puerta al menos 90° en cualquier dirección.

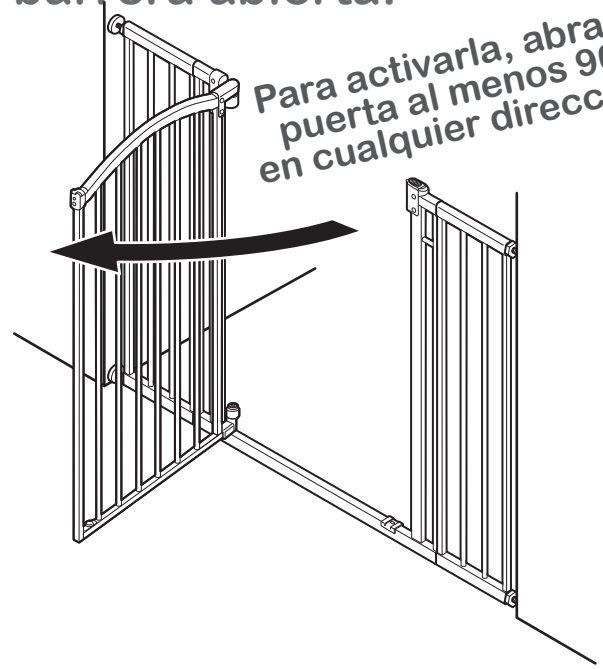

## solución de problemas:

Si la barrera no se cierra correctamente:

**1. La barrera no está correctamente alineada en el marco de la puerta.**

**Solución:** Para ajustar la alineación de la barrera, afloje los cuatro pernos de tensión y repositone la barrera para que coincida con la imagen "correcta". Vuelva a apretar los tornillos de tensión.

**2. Es necesario ajustar la presión de los pernos de tensión.**

**Solución:** Afloje o apriete los pernos de tensión superiores. Asegúrese de que el cierre superior quede bien enclavado al cerrar la puerta y de que pueda abrirse correctamente al empujar hacia atrás la lengüeta de cierre deslizante.

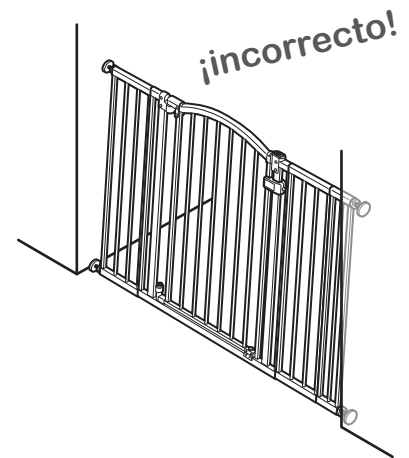
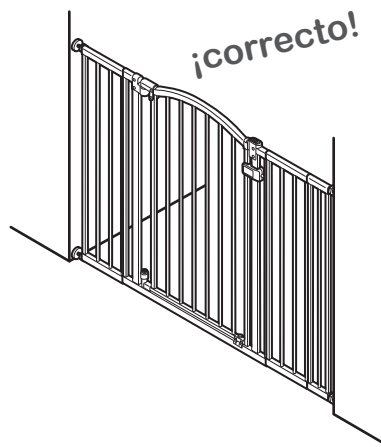

## mantenimiento:

- Compruebe regularmente los pernos tensores para asegurarse de que la barrera está bien sujeta.
- No utilice si algunos componentes están rotos o dañados o faltan.
- Limpie la superficie con un paño húmedo o una esponja con detergente suave y agua tibia.

MANUFACTURED FOR • FABRIQUÉ POUR **kids2™** & **oKids II®** ©2024 KIDS2, LLC [www.kids2.com/help](http://www.kids2.com/help)  
KIDS2, LLC ATLANTA, GA USA 30305 • 1-800-230-8190

IMPORTED BY • IMPORTÉ PAR

**KIDS2 CANADA CO.** PO BOX 54059, RPA LAWRENCE PLAZA, TORONTO, ON. M6A 3B7

**KIDS2 AUSTRALIA PTY LIMITED** CASTLE HILL, NSW AUSTRALIA 2154 • (02) 9894-1855

**KIDS2 JAPAN K.K. c/o ARK Outsourcing KK** 4-3-5-704, Ebisu, Shibuya-ku, Tokyo, Japan 150-0013 • (03) 5322-6081

**KIDS2 UK LTD.** GROUND FLOOR, SUITE A1A, BREAKSPEAR PARK, BREAKSPEAR WAY, HEMEL HEMPSTEAD,

HP2 4TZ • +44 01582 816 080

**KIDS2 EUROPE BV** 5 KEIZERS, KEIZERSGRACHT 287, 1016 ED AMSTERDAM, NETHERLANDS • +31 20 2410934

**KIDS2 US MÉXICO S.A. DE C.V.** • (55) 5292-8488

MADE IN CHINA • HECHO EN CHINA • FABRIQUÉ EN CHINE

Los colores y estilos pueden variar.

**HECHO EN CHINA.**

17172, 17173\_092624