

INSTRUCTION MANUAL

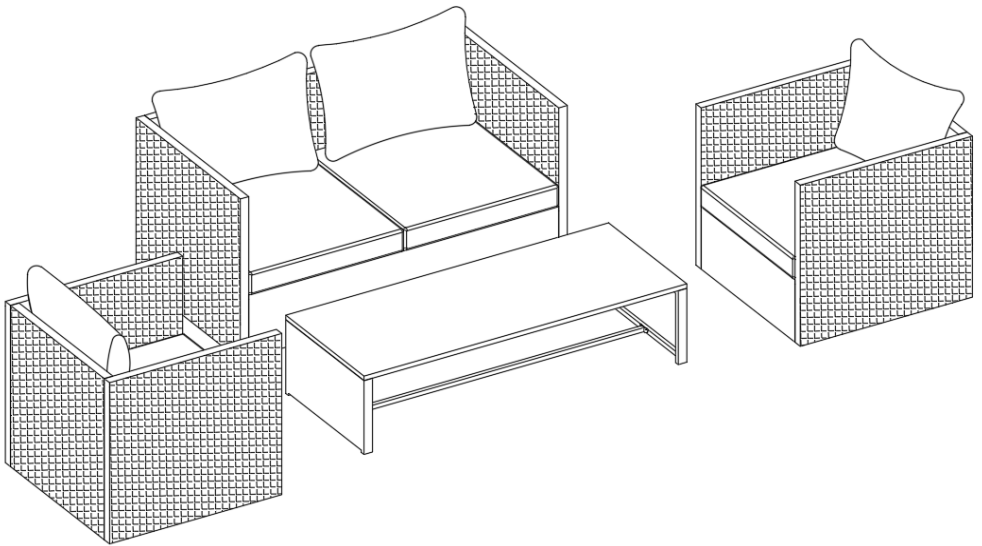

**4- Piece Woven Rattan Wicker Sofa Set
With Cushion**

SKU: P150

V 3.0

! NOTICE

Do not overtighten screws. (Insert all screws before tighten screws.)

- Please do not exceed the weight limitations of this item.
- Do not stand on or use any part of this item as a step ladder.
- Firmly secure all bolts, screws and nuts before use.
- Reconfirm that all bolts, screws, and nuts are secure every 90 days.
- Do not use or store this item in the proximity of open flame or flammable/combustible chemicals.
- Be aware that some parts are heavy and have sharp edges.

TOOLS REQUIRED



ALLEN WRENCH
(PROVIDED)



LBS
LOVESEAT
660 LBS
CAPACITY



LBS
CHAIR
330 LBS
CAPACITY



LBS
TABLE
110 LBS
CAPACITY



2 PERSONS
ASSEMBLY



UP TO 60 MIN.
ASSEMBLY

HARDWARE

1

M6 x40mm
BOLT



17 PCS

2

M6 x 35mm
BOLT



22 PCS

3

M6 x 15mm
BOLT



4 PCS

4

M6 WASHER



43 PCS

5

ALLEN
WRENCH



1 PC

PARTS

A

CHAIR RIGHT SIDE

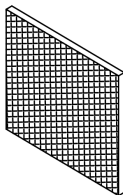

3 PCS

B

CHAIR LEFT SIDE

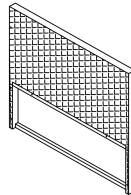

3 PCS

C

CHAIR SEAT

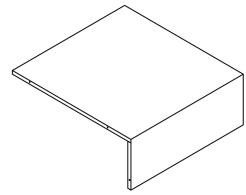

2 PCS

PARTS

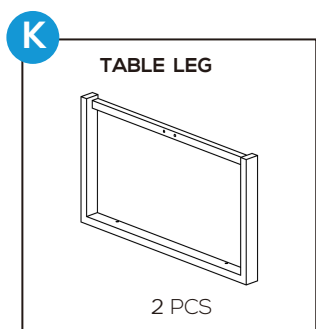
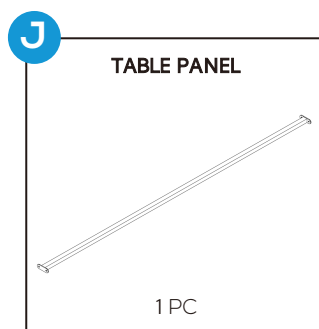
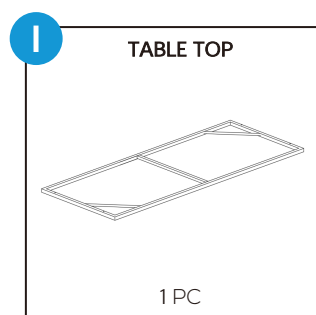
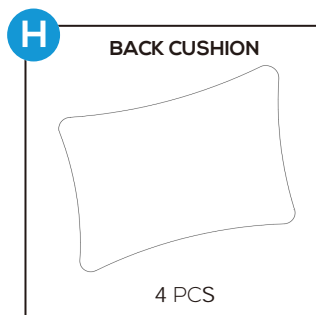
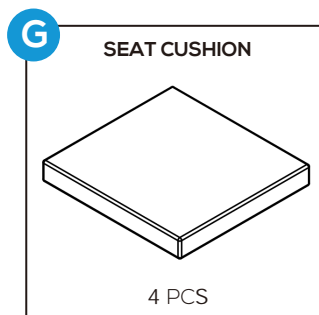
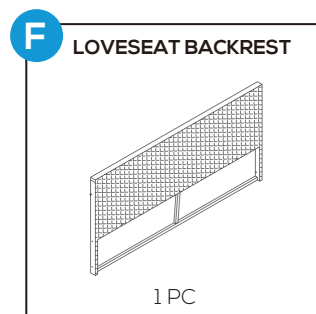
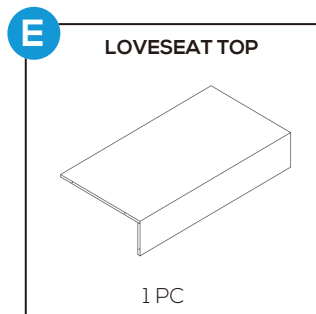
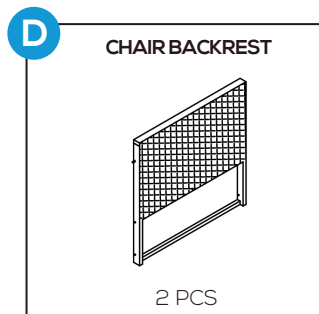

PRODUCT ASSEMBLY - CHAIR

1

Attach part D Chair Backrest to part C Chair seat with 1 PC of part 4 washer and part 1 bolt.

Do not tighten screws too much at this stage.

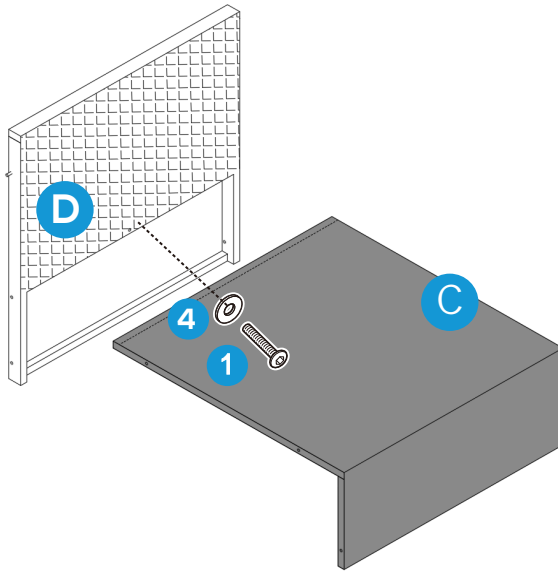

2

Attach part B Chair Left Side to part C Chair Seat and part D Chair backrest with 2 pcs of part 1 bolt and 3 pcs of part 2 bolt and 5 pcs of part 4 washer.

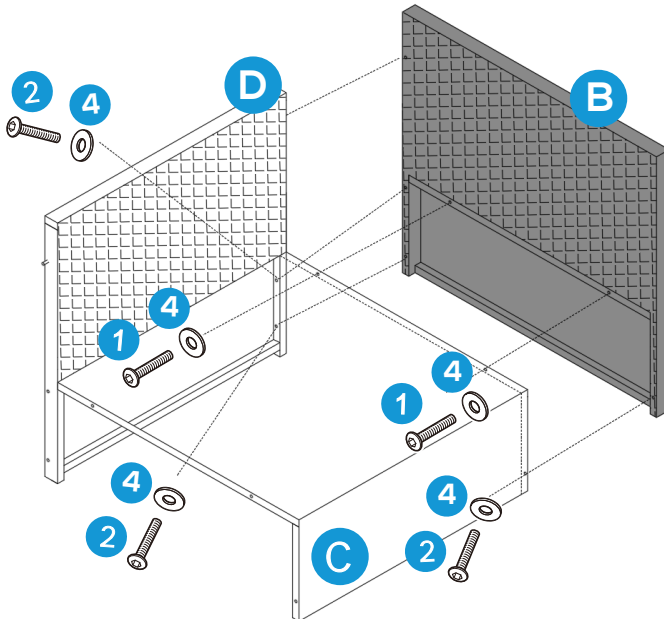

PRODUCT ASSEMBLY - CHAIR

3

Attach part A Chair Right Side to part D Chair Backrest and part C Chair Seat with 3 PCS of part 2 bolt and 2 PCS of part 1 bolt as well as 5 PCS of part 4 washer.

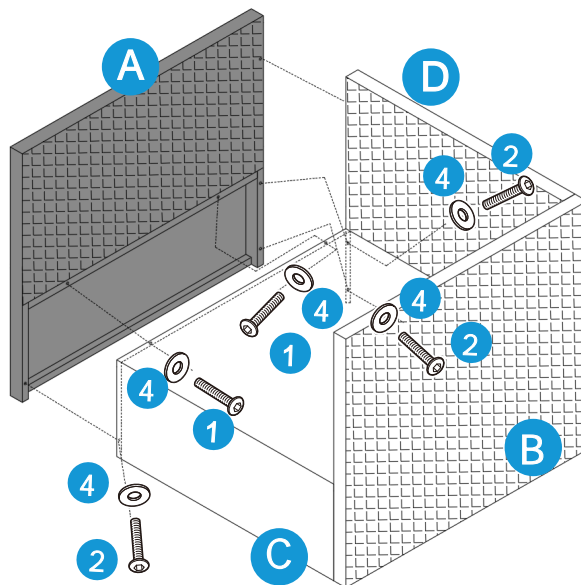

4

Place part G Seat Cushion and part H Back Cushion into the chair to finish the assembly. Do the same to assemble another chair.

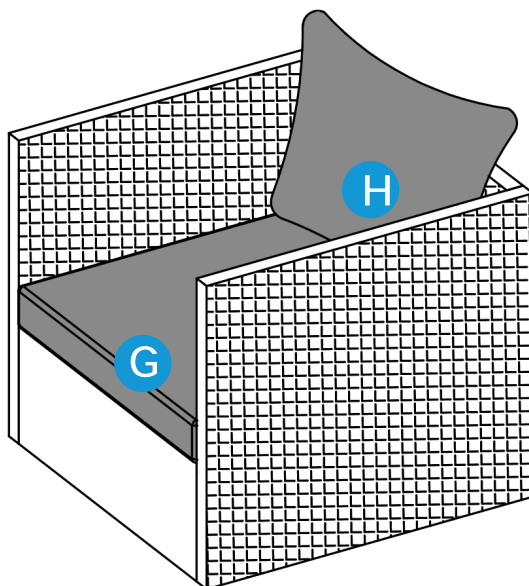

PRODUCT ASSEMBLY - LOVESEAT

1

Attach part F Chair Backrest to part E Loveseat TOP with 3 PCS of part 4 washer and part 1 bolt.

Do not tighten screws too much at this stage.

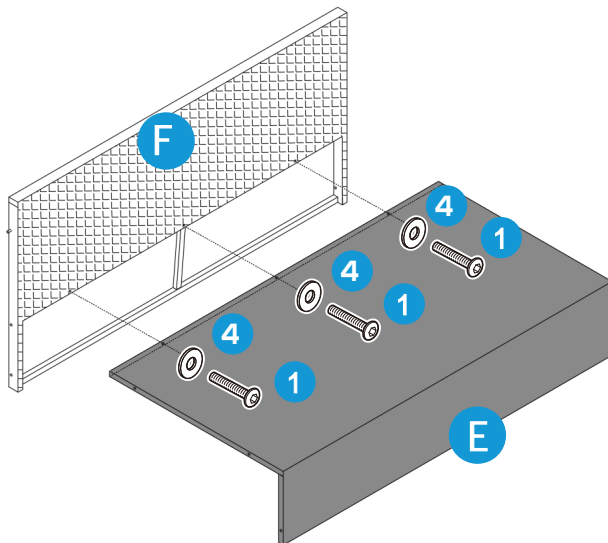

2

Attach part B Chair Left Side to part F Loveseat Backrest and part E Loveseat Top with 2 PCS of part 1 Bolt land 3 PCS of part 2 Bolt and 5 PCS of part 3 washer.

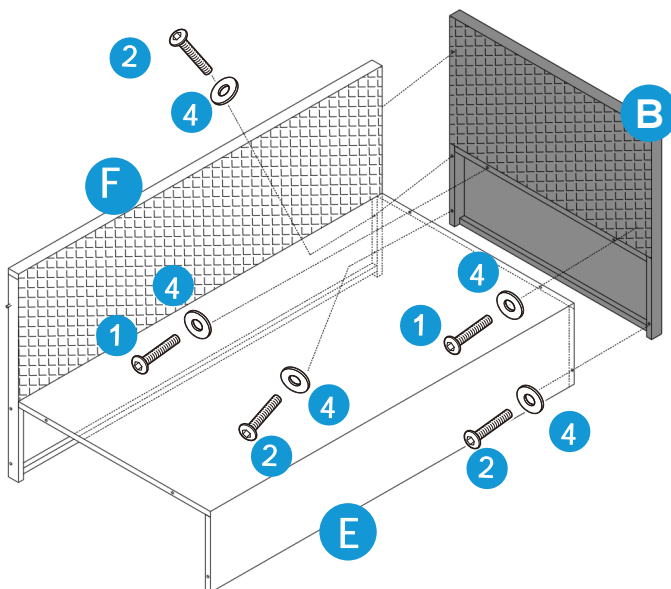

PRODUCT ASSEMBLY - LOVESEAT

3

Attach part A Chair Right Side to part F Loveseat Backrest and part E Loveseat Top with 3 PCS of part 2 bolt and 2 PCS of part 1 bolt as well as 5 PCS of part 4 washer.

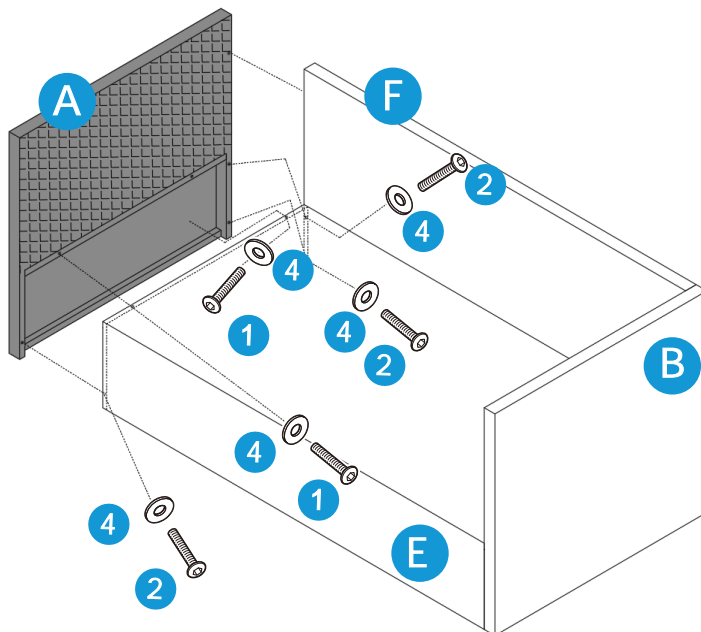

4

Place part G Seat Cushion and part H Back Cushion into the loveseat to finish assembly.

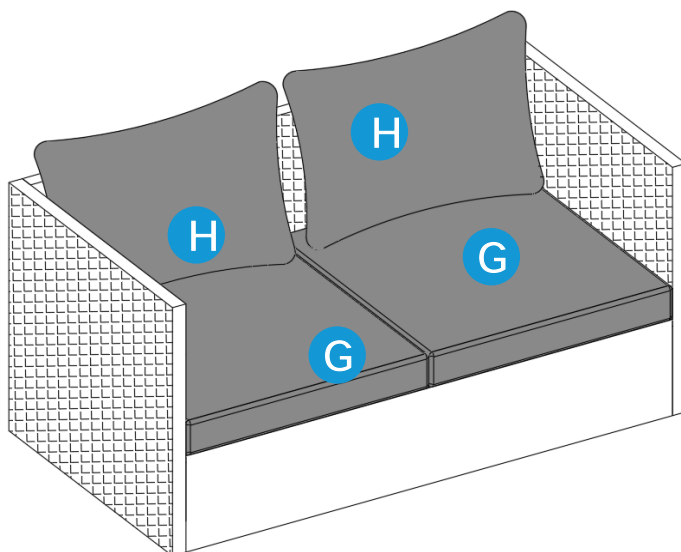

PRODUCT ASSEMBLY - COFFEE TABLE

1

Attach part K Table Leg to part I Table Top with 4 PCS of part 4 washer and part 2 bolt.

Do not tighten screws too much at this stage.

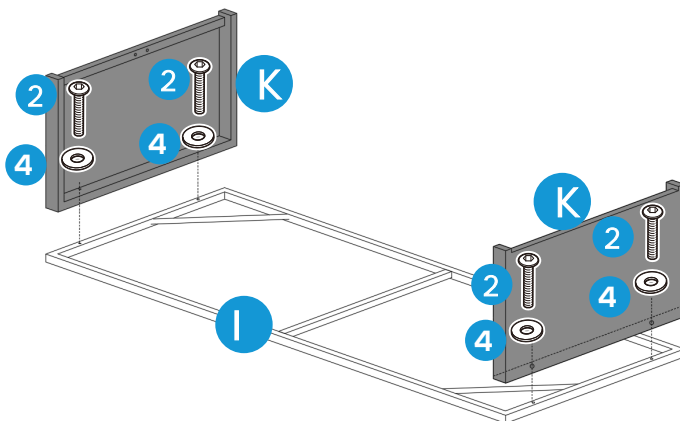

2

Attach part J Table panel to part K Table Legs with 4 PCS of part 4 washer and part 3 bolt.

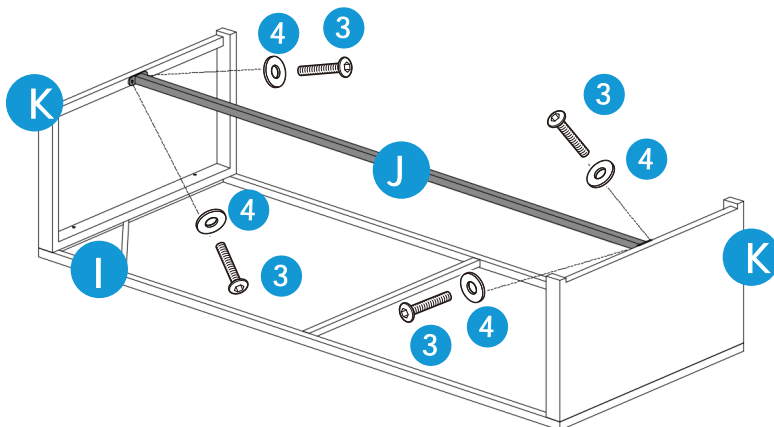

3

Congratulation, the assembly of coffee table finishes.

