

FLEXSTEEL®

W1027-90K1 / 90K2 / 90R3

King Bed

IMPORTANT

Carefully remove all parts from the carton, and put them individually on a soft cloth to prevent damage to the parts.

We have taken great care in the design of this product and request that you carefully and accurately follow our assembly instructions to ensure proper set-up.

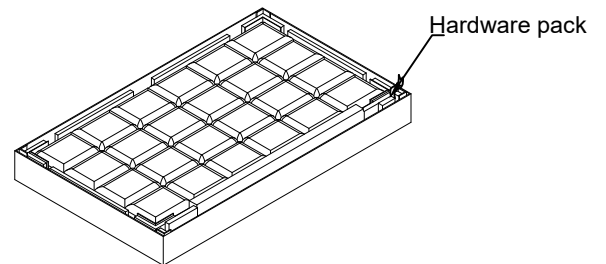
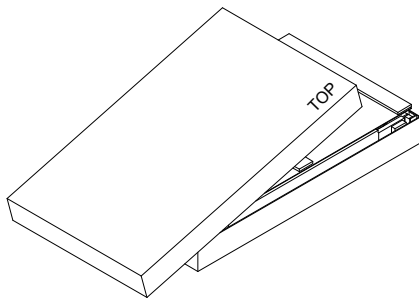
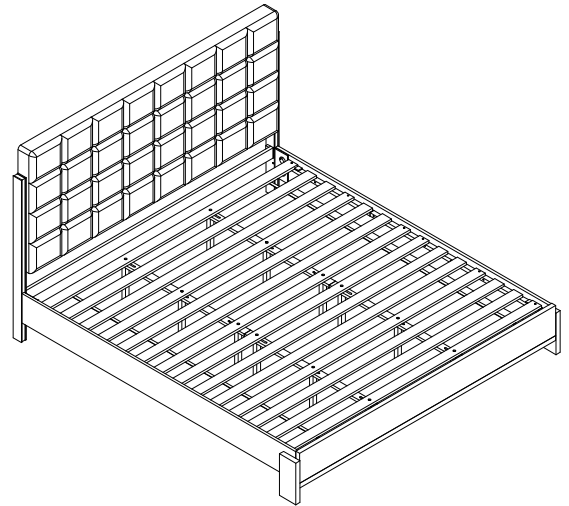

Part List

Assembly Instructions 1/4

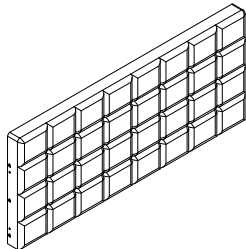

A. Headboard
1 piece

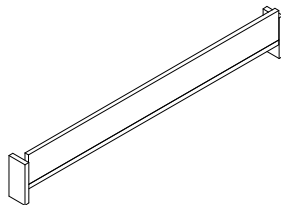

B. Footboard
1 piece

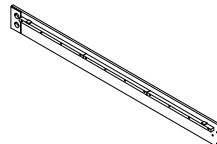

C. Side rail
2 pieces



D. Headboard Post Left
1 piece



E. Headboard Post Right
1 piece

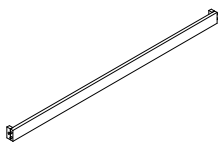

F. Headboard Bottom Rail
1 piece

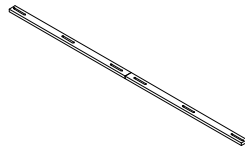

G. Center Rail
2 pieces

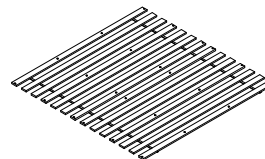

H. Roll Slats
1set



I. Slat Support
12 pieces

Hardware List

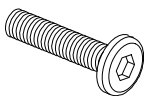

Bolt
5/16" x 1-1/2"
14 pieces



Spring Washer
5/16"
14 pieces



Flat Washer
5/16" x Ø19
14 pieces

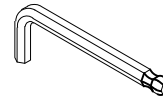

Hex Key
5/32"
1 piece

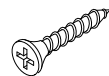

Screw
12 pieces

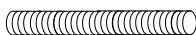

Thread Bolt
5/16" x 3-1/2"
4 pieces



Curved Washer
4 pieces



Hexagonal Nut
4 pieces

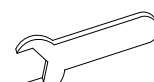

Spanner Wrench
1 pieces

FLEXSTEEL®

Assembly Instructions 2/4

IMPORTANT NOTES

- Do not tighten up all the bolts until each part is properly assembled.
- Keep the Hex Key in a safe place as you may need to tighten up the bolts in the future.
- Use a soft cloth between these parts and the floor.
- We recommend this product be assembled by at least two adults.

STEP 1

Fix Headboard Post Left (D) and Headboard Post Right (E) to Headboard (A) and Headboard Bottom Rail (F). Insert Bolt, Spring Washer, Flat Washer and fully tighten bolts with Hex Key. (See Figure 1)

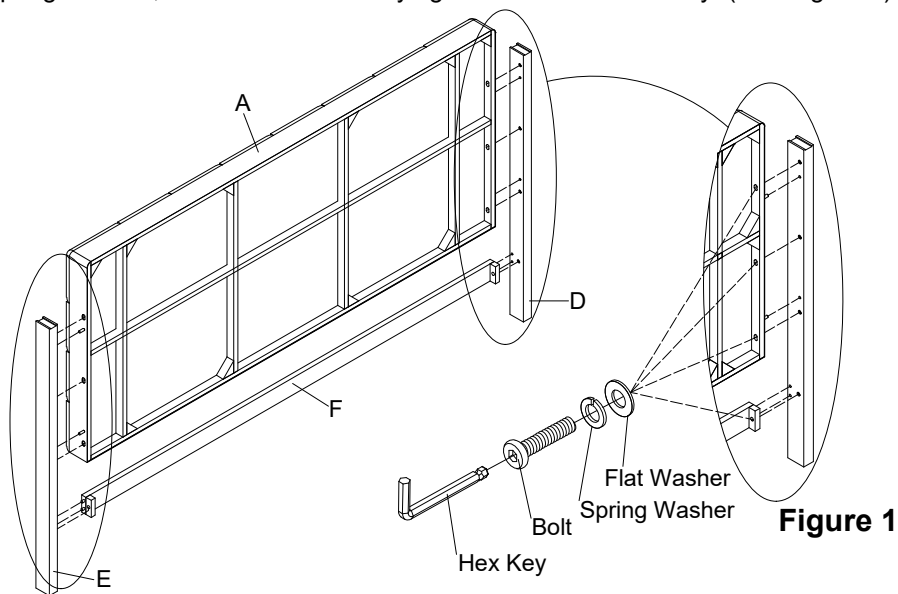

STEP 2

Connect the Side rail (C) to Headboard Post (D) and (E). Insert Thread Bolt, Curved Washer, Hexagonal Nut and fully tighten bolts with Spanner Wrench. (See Figure 2).

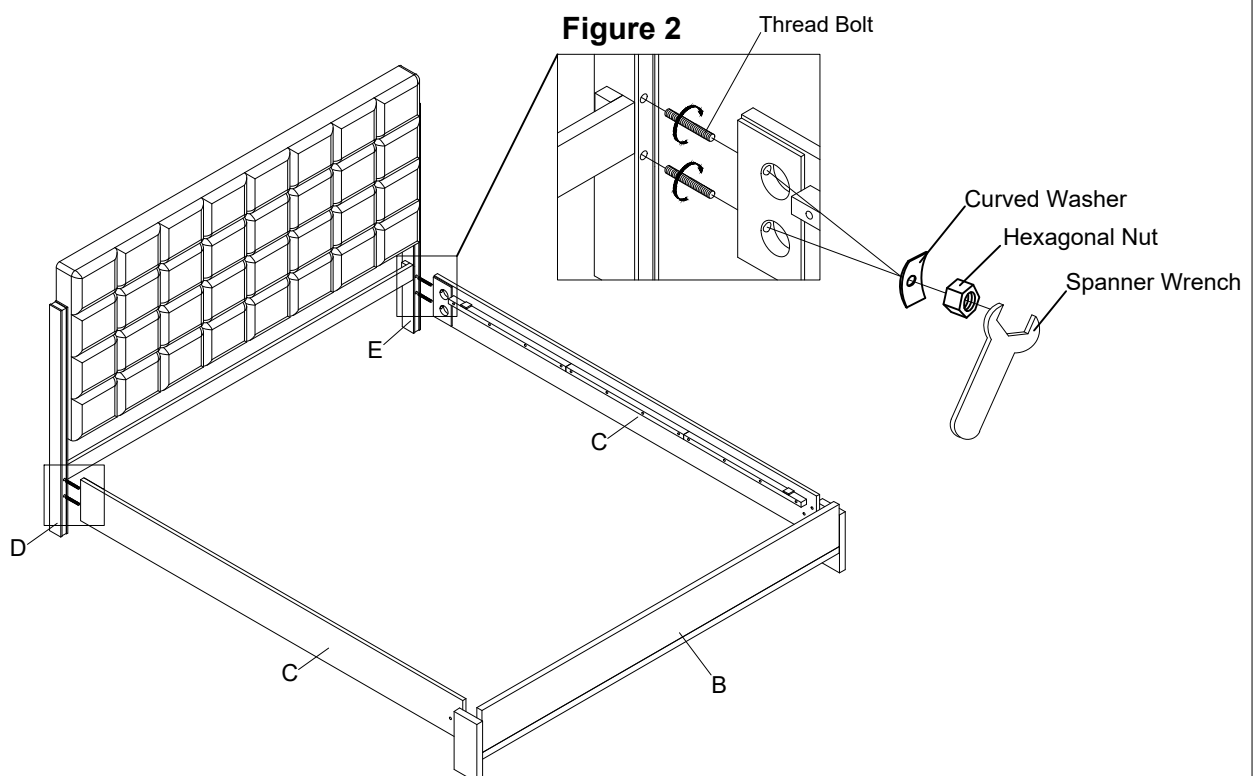

FLEXSTEEL®

Assembly Instructions 3/4

IMPORTANT NOTES

- Do not tighten up all the bolts until each part is properly assembled.
- Keep the Hex Key in a safe place as you may need to tighten up the bolts in the future.
- Use a soft cloth between these parts and the floor.
- We recommend this product be assembled by at least two adults.

STEP 3

Connect the Side rail (C) to Footboard (B). Insert Bolt, Spring Washer, Flat Washer and fully tighten bolts with Hex Key. (See Figure 3)

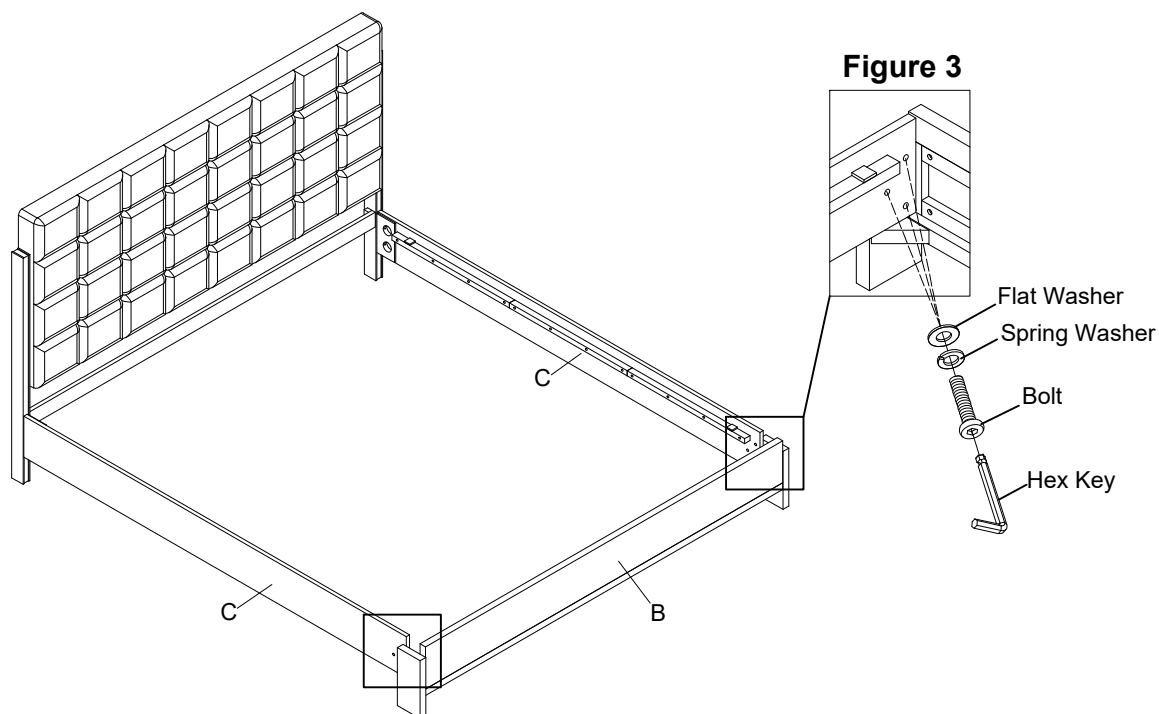

STEP 4

Connect the Slat Support (I) and Center Rail (G) to Roll Slats (H). (See Figure 4)

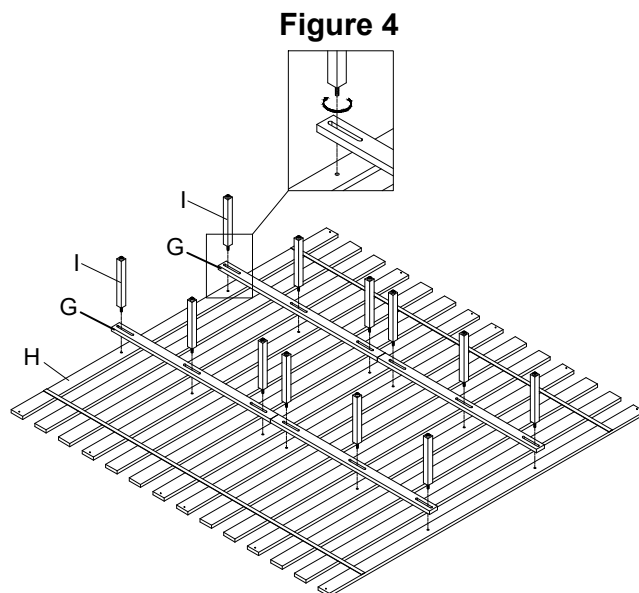

FLEXSTEEL®

Assembly Instructions 4/4

IMPORTANT NOTES

- Do not tighten up all the bolts until each part is properly assembled.
- Keep the Hex Key in a safe place as you may need to tighten up the bolts in the future.
- Use a soft cloth between these parts and the floor.
- We recommend this product be assembled by at least two adults.

STEP 5

Fix Roll Slats (H) to Side rail (C). Insert Screw.
(See Figure 5)

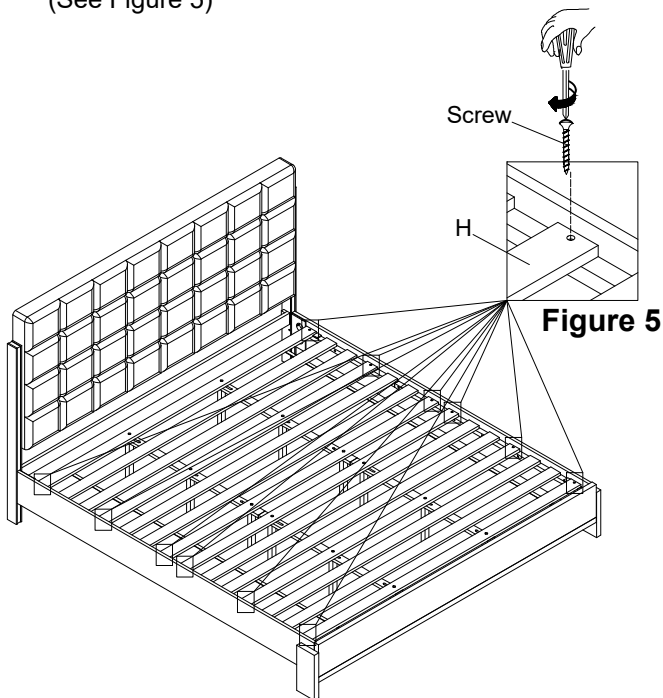

STEP 6

Adjust the levelers on the Slat Supports (I) touching the floor. (See Figure 6)

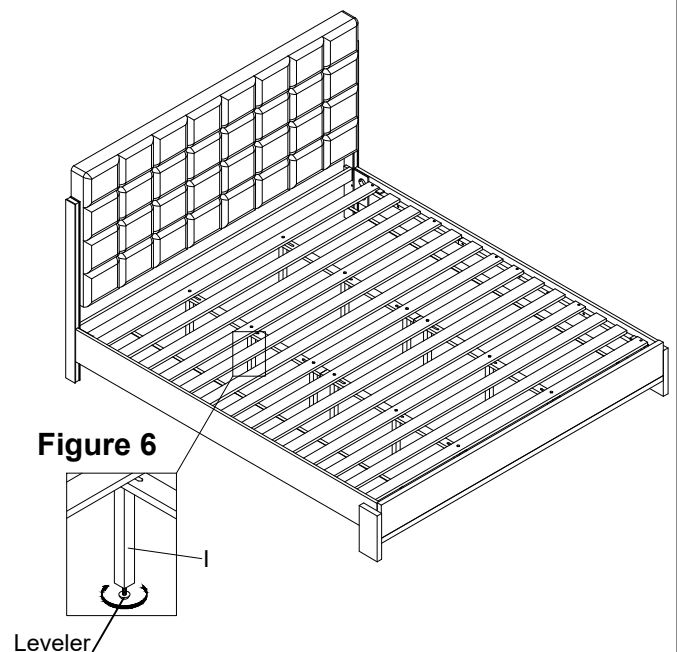

CARE INSTRUCTIONS

- To avoid scratches, do not place sharp or jagged objects directly on the table top.
- Do not place hot items directly on the table top.
- Use placemats or trivets under hot items and coasters under beverages to prevent marks and stains.
- Avoid the use of harsh chemicals or abrasive cleaning materials.
- Wipe the table clean with a soft, dry cloth after each use.
- Wipe up spills quickly with a soft, dry cloth.

Flexsteel Industries, Inc.

For Parts or Customer Service call

toll-free:

1-888-415-3979

Monday-Friday

8:00 a.m. -5:00 p.m.

(Central Time)

Email:

customersolutions@flexsteel.com

www.flexsteel.com