

INSTRUCTION MANUAL

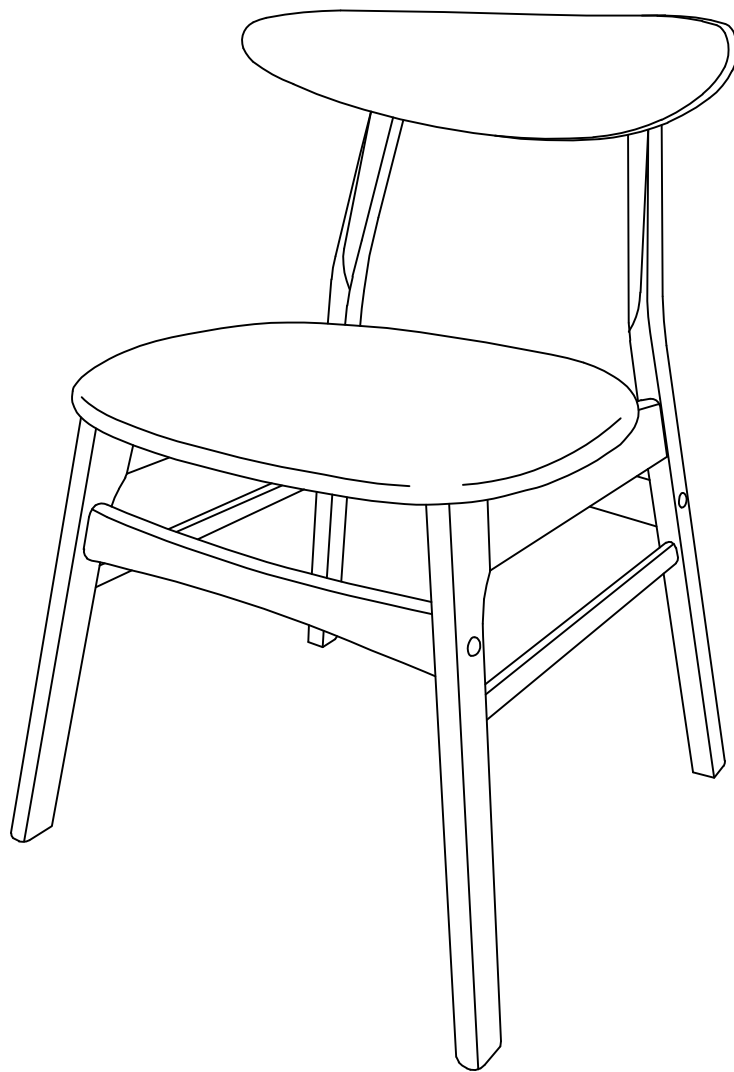

Lucia Solid Wood Upholsted Side Chair
SKU : ID304-SC

NOTICE

Please keep this instruction for your future reference.

- Please do not exceed the weight limitations of this item.
- Do not stand on or use any part of this item as a step ladder.
- Firmly secure all bolts, screws and nuts before use.
- Reconfirm that all bolts, screws, and nuts are secure every 90 days.
- Do not use or store this item in the proximity of open flame or flammable/combustible chemicals.
- Be aware that some parts are heavy and have sharp edges.
- Do not overtighten screws. (Insert all screws before tighten screws.)

TOOLS REQUIRED



ALLEN WRENCH
(PROVIDED)



CHAIR
65 LBS
CAPACITY









1 PERSON
ASSEMBLY

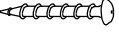

UP TO 60 MIN
ASSEMBLY

HARDWARE

- 1** WOOD DOWEL
M8 x 30mm

10 PCS
- 2** JCBC BOLT
M6 x 40mm

4 PCS
- 3** SPRING
WASHER M6

4 PCS
- 4** FLAT WASHER
M6 x 13mm

4 PCS
- 5** PEN HEAD
SCREW
M4 x 25mm

4 PCS
- 6** PEN HEAD
SCREW
M4 x 32mm

4 PCS
- 7** WOOD BUTTON
10.5mm

4 PCS
- 8** WOOD BUTTON
14.5mm

4 PCS

PARTS

A

FRONT & BACK RAIL



2 PCS

B

LEFT CHAIR SIDE

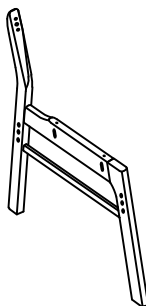

1 PCS

C

RIGHT CHAIR SIDE

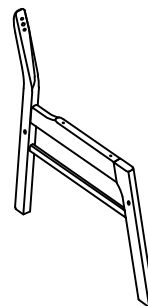

1 PCS

D

BACK TOP



1 PCS

E

CUSHION SEAT



1 PCS

PRODUCT ASSEMBLY - CHAIR

1

Hammering part 1 wood dowel into Part A, Part B and Part C.

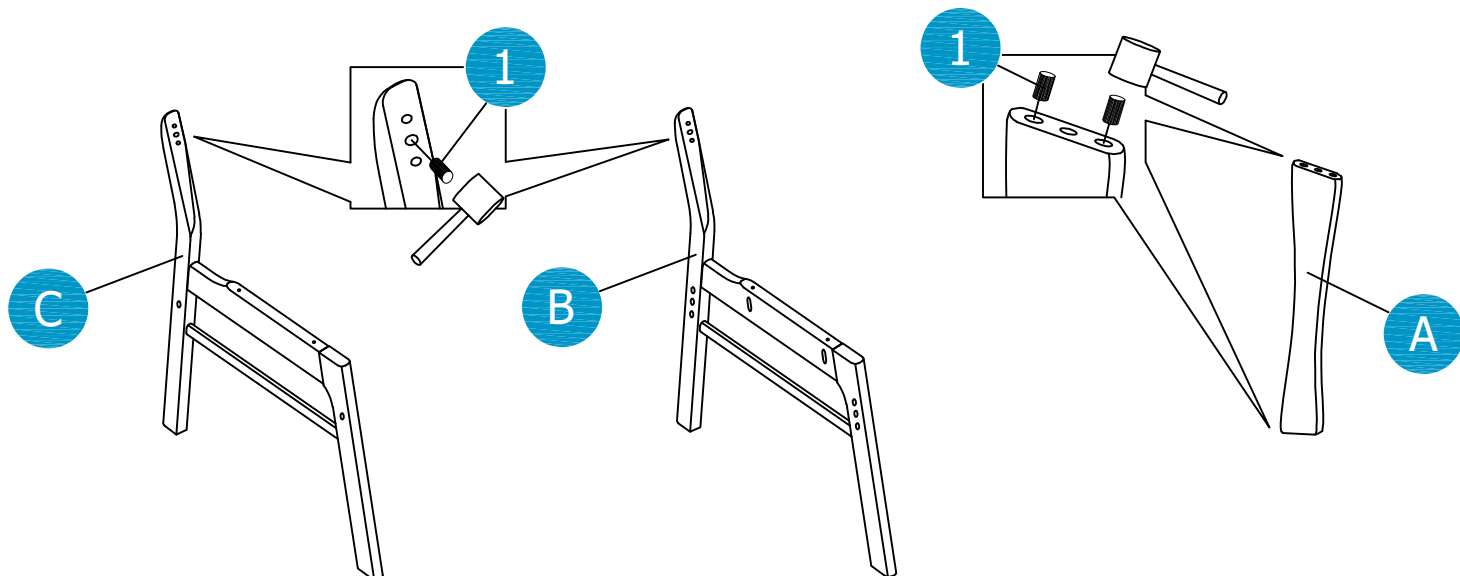

2

Assemble Part A front & back rail to Part B left chair side with 2pcs of part 2 screw, 2pcs of part 3 spring washer and 2pcs of part 4 flat washer. Do not tighten screws too much at this stage.

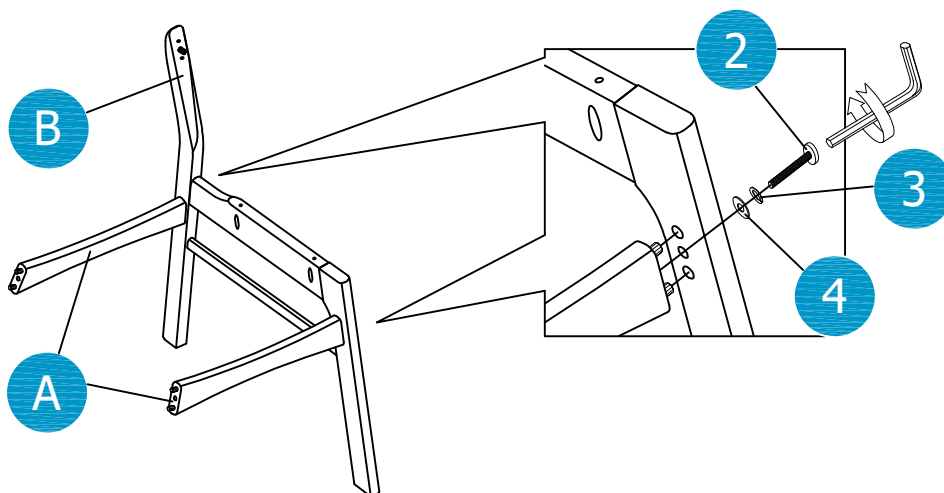

3

Assemble Part C right chair side to Part A front & back rail with 2pcs of part 2 screw, 2pcs of part 3 spring washer and 2pcs of part 4 flat washer. Do not tighten screws too much at this stage.

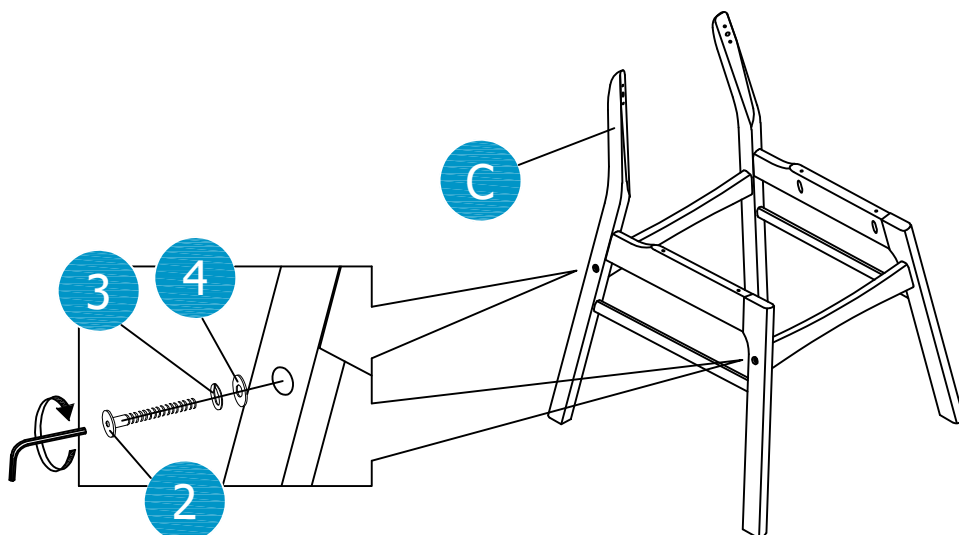

PRODUCT ASSEMBLY - CHAIR

4

Assemble Part D back top to Part B & Part C chair side with 4pcs of part 5 screw. Assemble Part 7 wood button into Part B & Part C chair side.

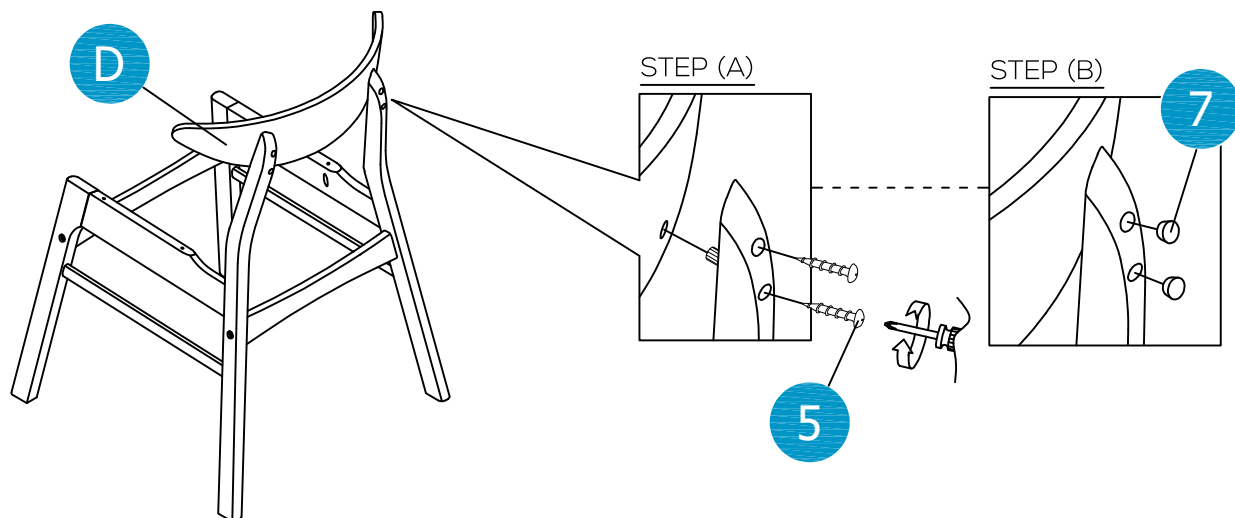

5

Assemble Part E cushion seat to Part B & Part C chair side with 4pcs of part 6 screw.

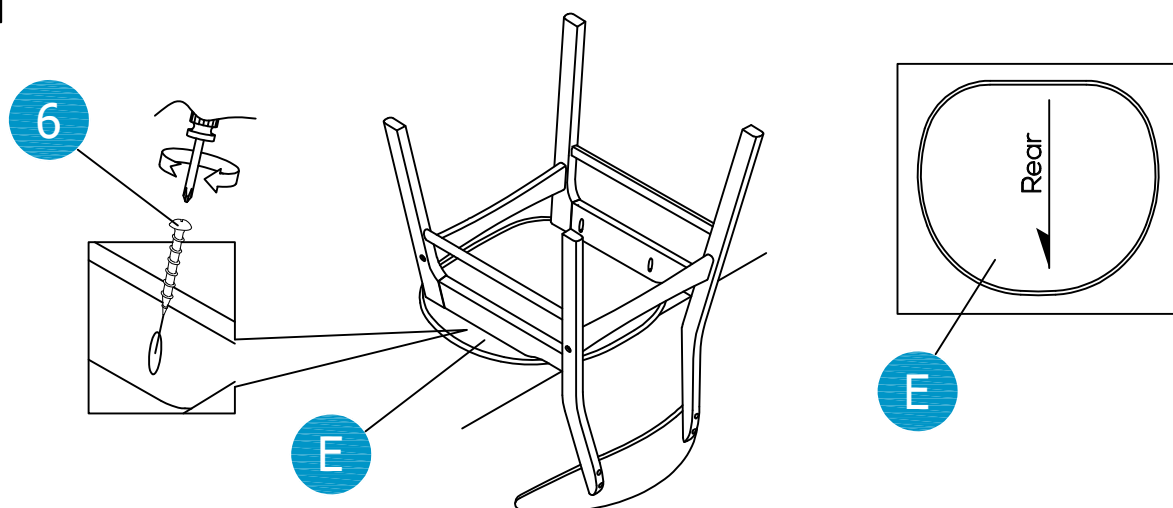

6

Tighten all the screws again to Part 2 and Part 3. Assemble Part 8 wood button into Part B & Part C chair side ensure the dining chair is stable enough to use.

