

homestyles

88 5560 66

Umbrella



IMPORTANT

Carefully remove all the parts from the carton and place them individually on a soft cloth to prevent scratches or other damage.

Carefully and strictly follow these assembly instructions to ensure a completed product as designed.

Do not use power tools above 8 volts to assemble.

Part List



A.
Top
1 pc.



B.
Bottom
1 pc.

Assembly Instructions 2/2

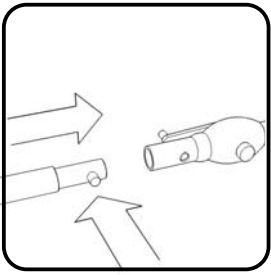
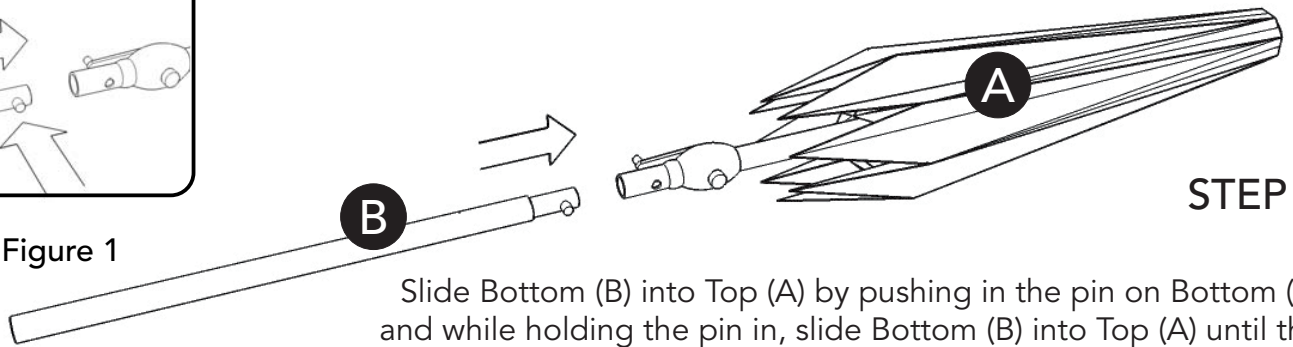

Figure 1



STEP 1

Slide Bottom (B) into Top (A) by pushing in the pin on Bottom (B) and while holding the pin in, slide Bottom (B) into Top (A) until the pin pops out of the hole in Top (A). (See Figure 1)

STEP 2

Slide the umbrella into the hole in the table top. (See Figure 2)

Loosen the knob on the already assembled umbrella stand; slide the umbrella into the umbrella stand and then tighten the umbrella stand knob. (See Figure 3)

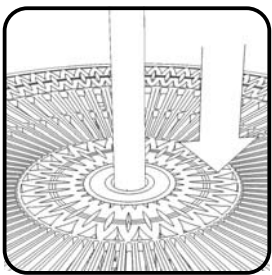

Figure 2

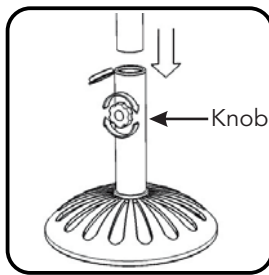

Figure 3

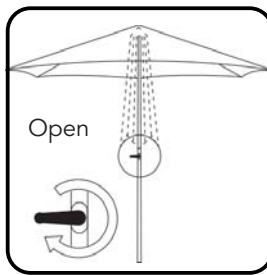

Figure 4

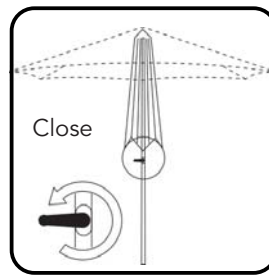

Figure 5

STEP 3

Open the umbrella by turning the handle clockwise until the umbrella is fully opened. (See Figure 4)

Close the umbrella by turning the handle counter-clockwise until the umbrella is fully closed. (See Figure 5)

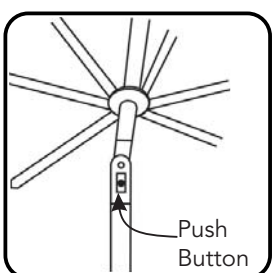
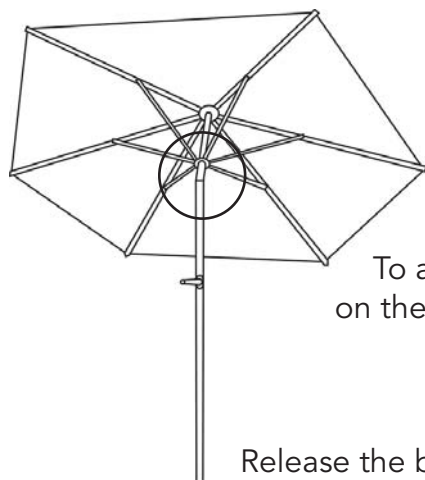
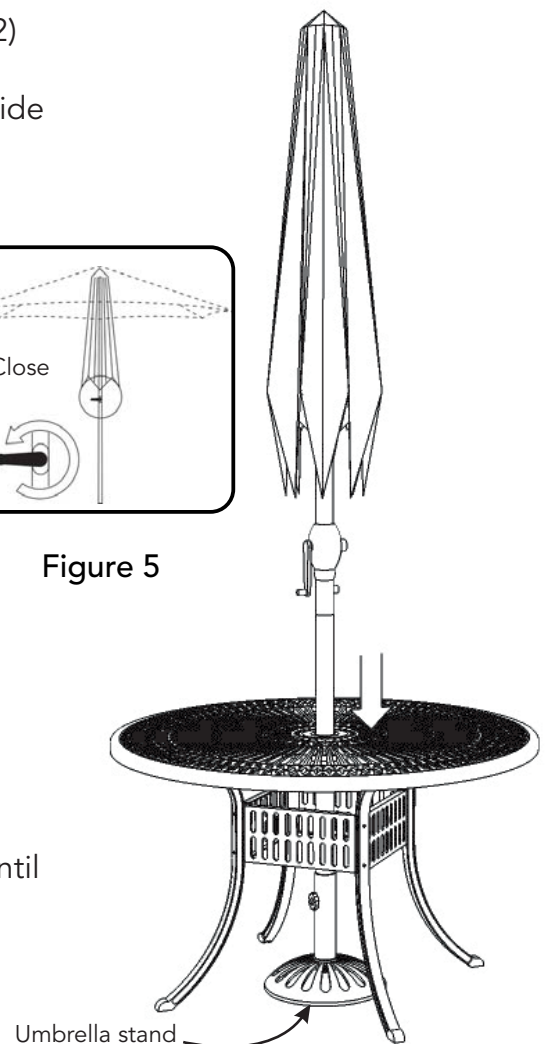

Figure 6



Release the button to lock the umbrella into the new position.



STEP 4

To adjust the angle of the umbrella, press the button on the top section of the umbrella and adjust the angle of umbrella section above the button. (See Figure 6)

CARE INSTRUCTIONS

NEVER

allow liquids to remain on furniture.
Absorption causes parts to warp
and split and finishes to delaminate.

NEVER

use glass cleaners on
finished furniture. Ammonia
chemically attacks the finish.



Do not use power tools
above 8 volts to assemble.
**PREVENT
CRACKING**



Do not place
in direct sunlight.
**PREVENT
FADING**



Do not write
directly on surface.
**PREVENT
MARKING**



Do not place hot
objects on surface.
**PREVENT
FINISH DAMAGE**

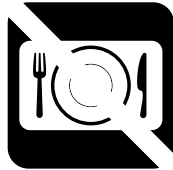

Do not use rubber
based placemats.
**PREVENT
DISCOLORING**



Do not use commercial
waxes and polishes.
**PREVENT
YELLOWING**

CLEAN

with a soft cloth moistened
in lukewarm soap and water.
Buff with a dry clean cloth.



Home Styles will provide replacements free of charge for missing or damaged hardware or parts within 30 days of purchase. Digital images of the defective parts may be required. If the product was not purchased from an authorized retail affiliate, Home Styles is under no obligation to provide replacement parts. Parts are not available for fully assembled items nor are parts available for sale. Replacements for missing or damaged hardware or parts may be requested at:

www.homestyles-furniture.com/customer-service/replacement-parts

Home Styles Customer Service: www.homestyles-furniture.com,
servicedesk@homestyles-furniture.com, 888-680-7460, 877-831-0319