

# ASSEMBLY INSTRUCTION

## 48" DINING TABLE

**A** TABLE TOP

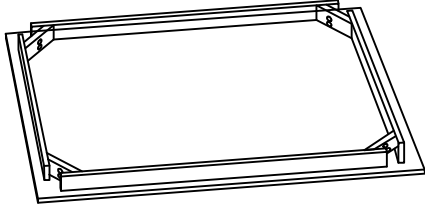

1 pc

**B** TABLE LEG

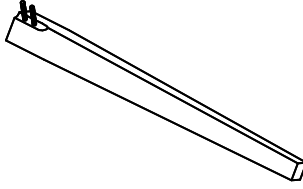

4 pcs

**C** HEX NUT  
Ø 5/16" x 12 mm

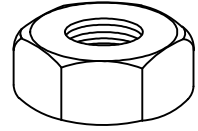

8 pcs

**D** FLAT WASHER  
Ø 5/16" x 19 mm

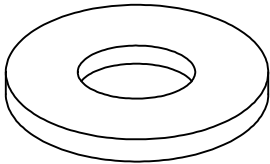

8 pcs

**E** LOCK WASHER  
Ø 5/16" x 13 mm

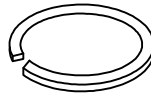

8 pcs

**F** WRENCH  
12 mm

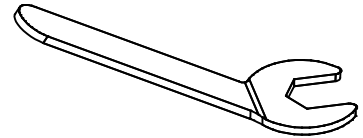

1 pc

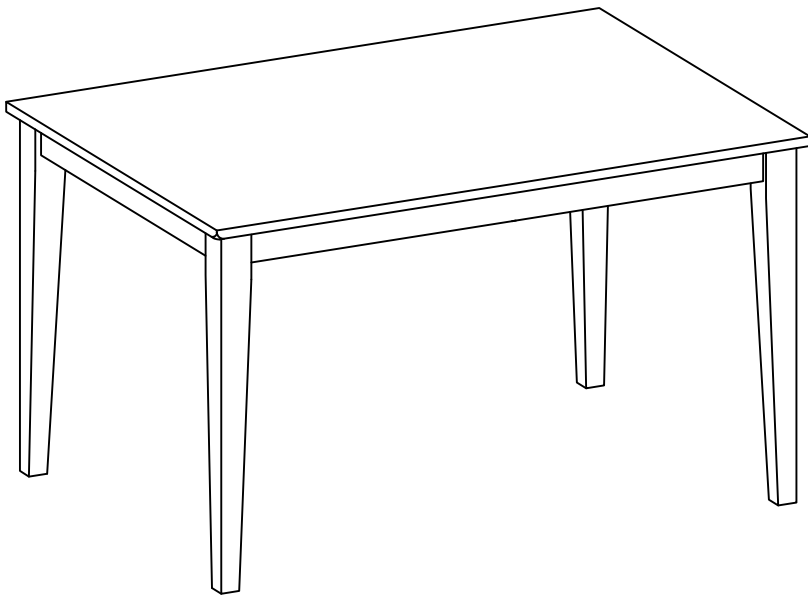

This page lists all the contents included in the box. Please take the time to identify the hardware as well as the individual components to this product. As you unpack and prepare for assembly, place the contents on a carpeted or padded area to protect them from damage.

**1** Place the Table Top (A) up side down on the floor with a piece of cloth or carpet underneath to prevent the finish from scratching. Attach the Table Leg (B) to Table Top (A) using Flat Washer (D), Lock Washer (E) and Hex Nut (C) by Wrench (F). Do not fully tighten.

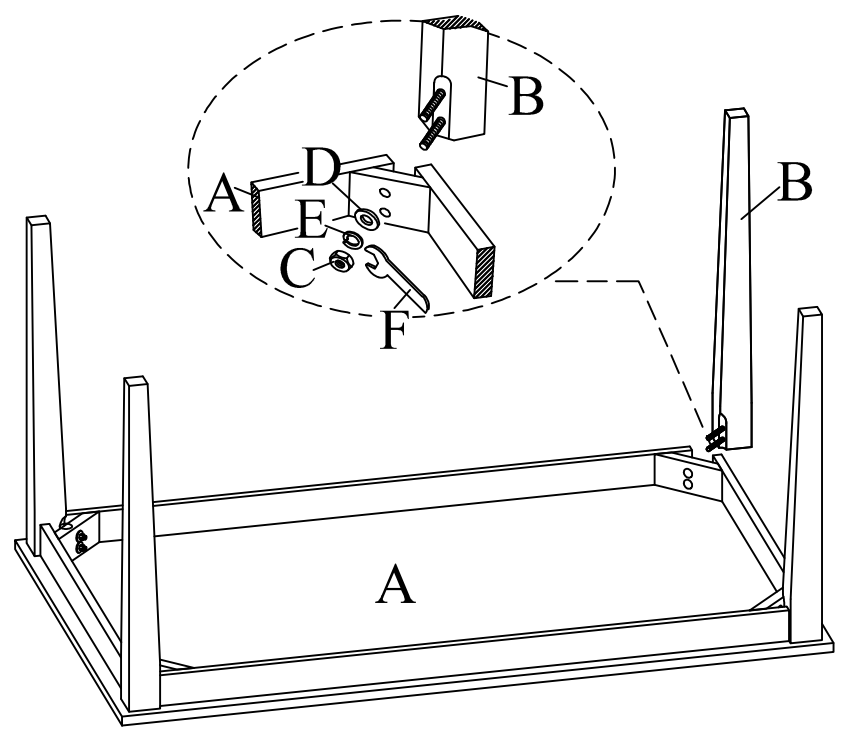



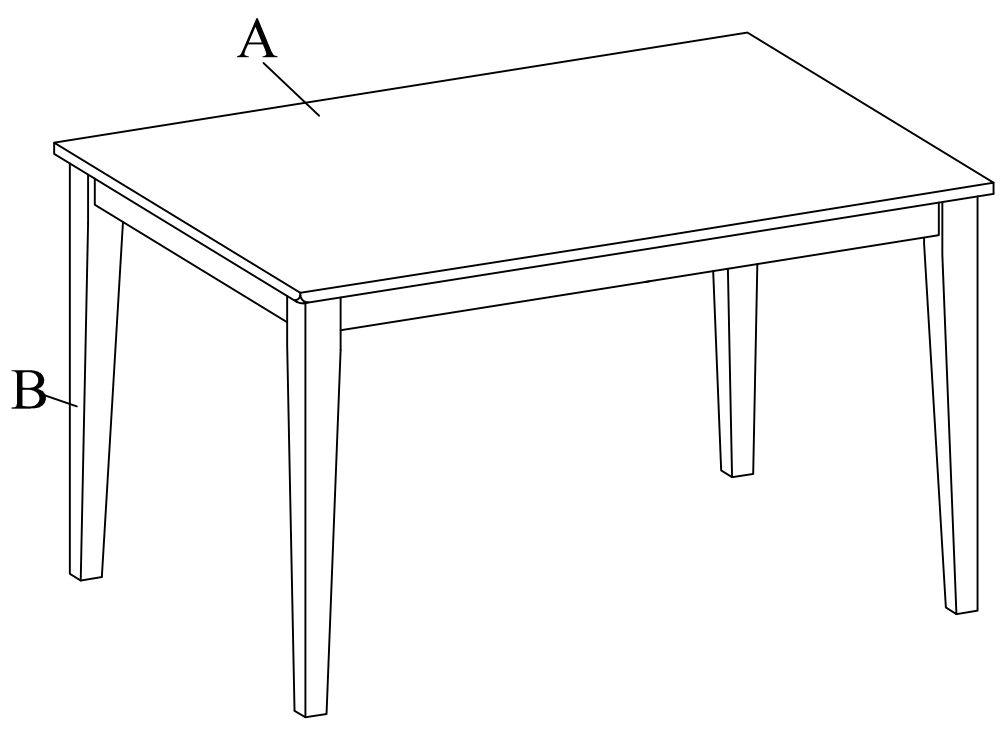





**2** Turn the Table to upright position, place it on flat surface and adjust legs so that Table is level and does not wobble. Assembly product is now completed .

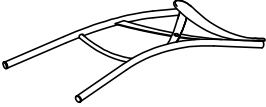

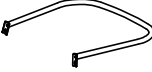
**Cleaning & Care :**  
Treat surface with care. Surface is resistant to scratches but is not scratch resistant. Clean surface with a dry or damp soft cloth. Do not use abrasive cleaners. Hardware may loosen over time. Periodically check that all connections are tight.

# ASSEMBLY INSTRUCTION

## DINING CHAIR

<b>A</b> Chair Back	<b>B</b> Seat	<b>C</b> Stretcher	<b>D</b> Front Leg
			
1pc	1pc	1pc	2pcs
<b>E</b> Bolt Ø1/4"x5/8"	<b>F</b> Lock Washer Ø1/4"x3/8"	<b>G</b> Flat Washer Ø1/4"x1/2"	<b>H</b> Allen Key M4
			
10pcs	10pcs	10pcs	1pc

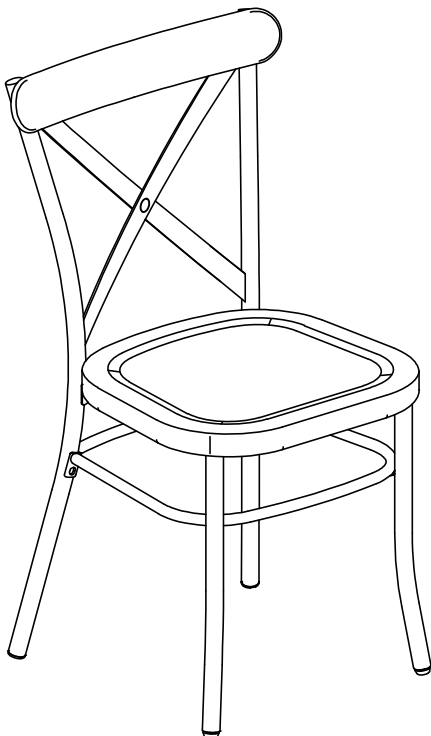

This page lists all the contents included in the box. Please take the time to identify the hardware as well as the individual components to this product. As you unpack and prepare for assembly, place the contents on a carpeted or padded area to protect them from damage.

- 
- 1** Attach Seat (B) to the Chair Back (A) using Bolt (E), Lock Washer (F) and Flat Washer (G) by Allen Key (H).

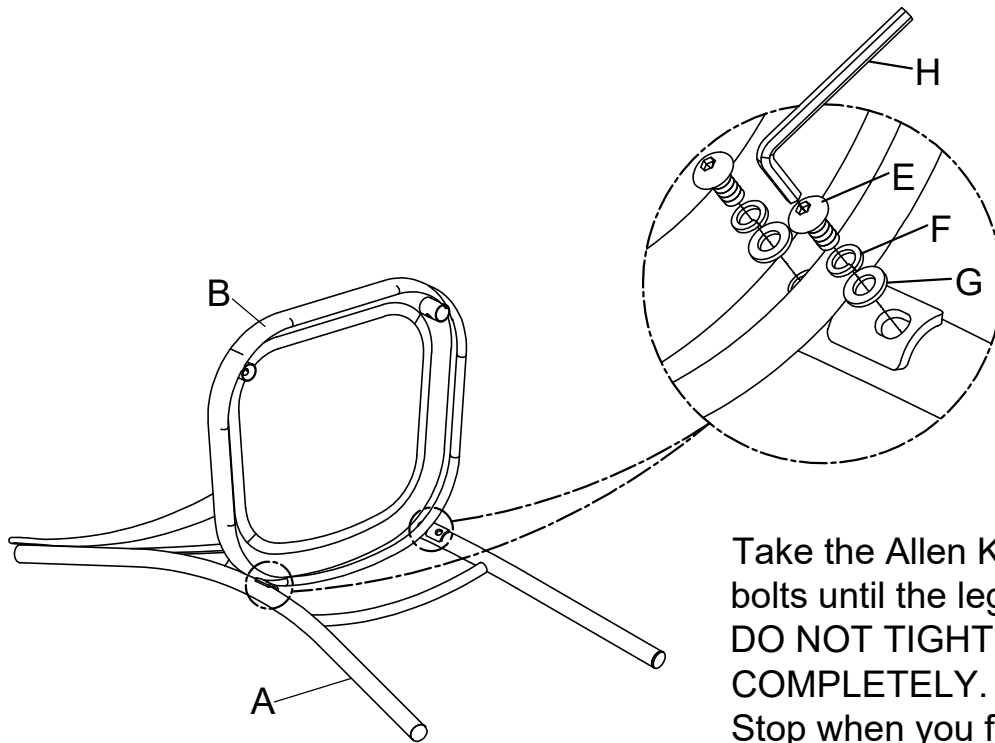

Take the Allen Key, and turn the bolts until the legs are secure. **DO NOT TIGHTEN COMPLETELY.** Stop when you feel you are adding force to tighten the bolt.

- 
- 2** Attach Stretcher (C) to the Chair Back (A) using Bolt (E), Lock Washer (F) and Flat Washer (G) by Allen Key (H).

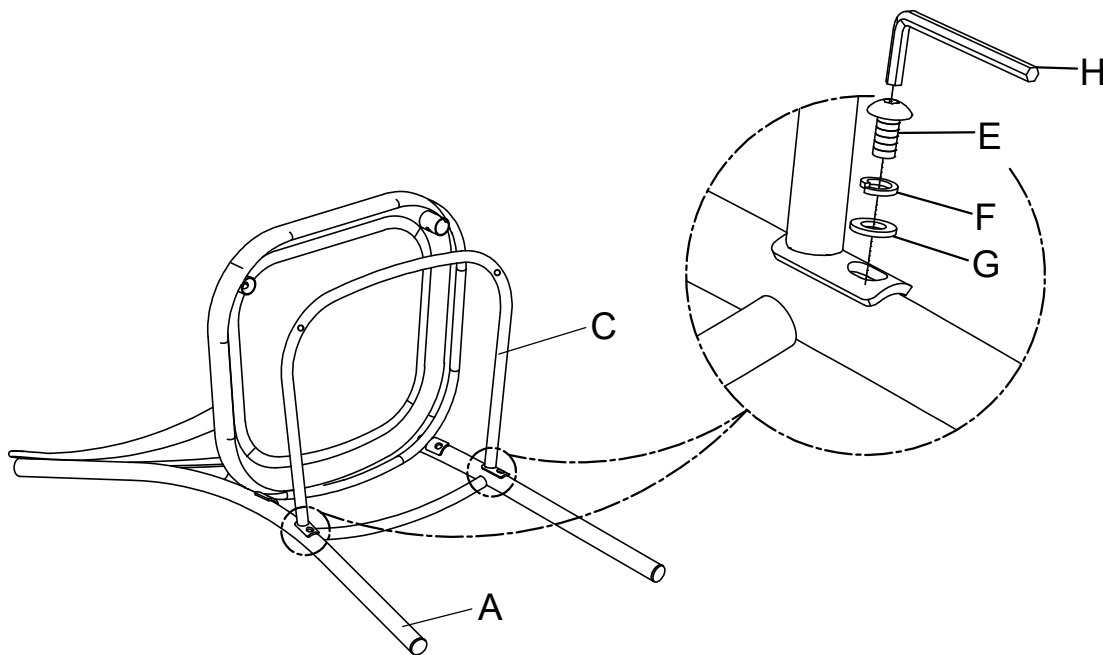

**3** Attach Front Leg (D) to Seat (B), Stretcher (C) using Bolt (E), Lock Washer (F), Flat Washer (G) by Allen Key (H).

Stand chair up on an even surface and check that it is balanced. If there is a slight wobble, apply downward pressure in the corner where a leg is uneven. Keeping pressure in that corner, tighten all bolts. If balanced, apply downward pressure evenly in the center and tighten all bolts. Do not over-tighten beyond hole depth.

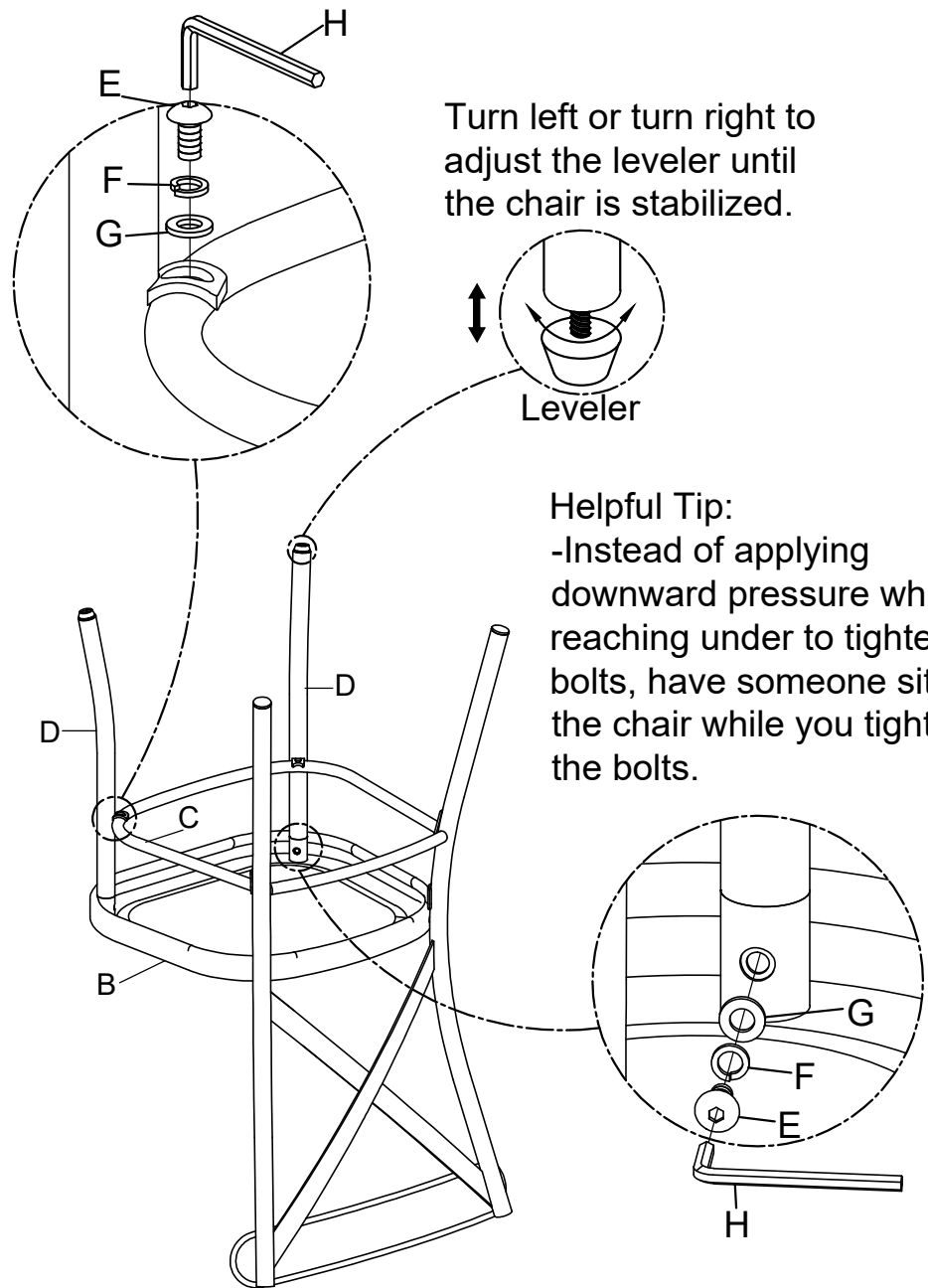

**Cleaning & Care**

Treat surface with care. Surface is resistant to scratches but is not scratch resistant. Clean surfaces with a dry or damp soft cloth. Do not use abrasive cleaners. Hardware may loosen over time. Periodically check that all connections are tight.